

Dura-Flo™ Lowers

311827G

EN

Stainless steel lowers with severe-duty rod and cylinder used for spray or transfer of common industrial coatings and adhesives. For professional use only.

Dura-Flo 600 (145 cc) Lowers

Dura-Flo 750 (180 cc) Lowers

Dura-Flo 900 (220 cc) Lowers

Dura-Flo 1200 (290 cc) Lowers



Important Safety Instructions

Read all warnings and instructions in this manual.
Save these instructions.

See page 2 for model information, including maximum working pressure.

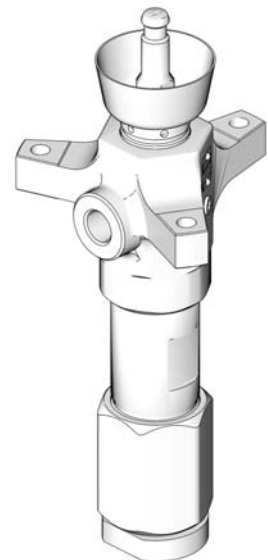

T18343a

Contents

Models	2	Dura-Flo 1200 (290 cc) Lower	13
Warnings	3	Repair Kits	14
Repair	5	Leather Packings with PTFE Backup	14
Pressure Relief Procedure	5	PTFE Packings	15
Required Tools	5	UHMWPE and PTFE Packings	16
Disassembly	5	UHMWPE and Leather Packings	17
Reassembly	8	Technical Data	19
Parts	10	Dimensions	19
Dura-Flo 600 (145 cc) and Dura-Flo 750 (180 cc) Lower	11	Graco Standard Warranty	20
Dura-Flo 900 (220 cc) Lower	12	Graco Information	20





Models





Lower Part No.	Series	Model	Packing Stacks	Maximum Fluid Working Pressure
247168*	A	Dura-Flo 600 (145 cc)	4 leather/1 PTFE backup	41 MPa (414 bar, 6000 psi)
241177	A	Dura-Flo 600 (145 cc)	3 UHMWPE/2 PTFE	41 MPa (414 bar, 6000 psi)
236458	A	Dura-Flo 600 (145 cc)	4 leather/1 PTFE backup	41 MPa (414 bar, 6000 psi)
L14BSS	A	Dura-Flo 600 (145 cc)	3 UHMWPE/2 PTFE	41 MPa (414 bar, 6000 psi)
L145SS	A	Dura-Flo 600 (145 cc)	3 UHMWPE/2 PTFE	41 MPa (414 bar, 6000 psi)
236456	B	Dura-Flo 750 (180 cc)	4 leather/1 PTFE backup	47 MPa (469 bar, 6800 psi)
261657*	A	Dura-Flo 750 (180 cc)	4 leather/1 PTFE backup	47 MPa (469 bar, 6800 psi)
L180SS	A	Dura-Flo 750 (180 cc)	3 UHMWPE/2 PTFE	47 MPa (469 bar, 6800 psi)
247190*	A	Dura-Flo 900 (220 cc)	4 leather/1 PTFE backup	41 MPa (414 bar, 6000 psi)
236470	A	Dura-Flo 900 (220 cc)	4 leather/1 PTFE backup	41 MPa (414 bar, 6000 psi)
248816	A	Dura-Flo 900 (220 cc)	5 UHMWPE throat/5 PTFE piston	41 MPa (414 bar, 6000 psi)
236897	A	Dura-Flo 900 (220 cc)	5 PTFE	41 MPa (414 bar, 6000 psi)
L22BSS	A	Dura-Flo 900 (220 cc)	3 UHMWPE/2 PTFE	41 MPa (414 bar, 6000 psi)
L220SS	A	Dura-Flo 900 (220 cc)	3 UHMWPE/2 PTFE	41 MPa (414 bar, 6000 psi)
247192*	A	Dura-Flo 1200 (290 cc)	4 leather/1 PTFE backup	41 MPa (414 bar, 6000 psi)
237514	A	Dura-Flo 1200 (290 cc)	4 leather/1 PTFE backup	41 MPa (414 bar, 6000 psi)
237515	A	Dura-Flo 1200 (290 cc)	3 UHMWPE/2 leather	41 MPa (414 bar, 6000 psi)
236490	A	Dura-Flo 1200 (290 cc)	5 PTFE	41 MPa (414 bar, 6000 psi)
L290SS	A	Dura-Flo 1200 (290 cc)	3 UHMWPE/2 PTFE	41 MPa (414 bar, 6000 psi)
24B923	A	Dura-Flo 1200 (290 cc)	3 UHMWPE/2 CF-PTFE	41 MPa (414 bar, 6000 psi)

* This lower can be connected only to NXT[®] 2200 size motors.

Warnings

The following warnings are for the setup, use, grounding, maintenance, and repair of this equipment. The exclamation point symbol alerts you to a general warning and the hazard symbol refers to procedure-specific risk. Refer back to these warnings. Additional, product-specific warnings may be found throughout the body of this manual where applicable.

 WARNING	
	<p>FIRE AND EXPLOSION HAZARD</p> <p>Flammable fumes, such as solvent and paint fumes, in work area can ignite or explode. To help prevent fire and explosion:</p> <ul style="list-style-type: none"> • Use equipment only in well ventilated area. • Eliminate all ignition sources; such as pilot lights, cigarettes, portable electric lamps, and plastic drop cloths (potential static arc). • Keep work area free of debris, including solvent, rags and gasoline. • Do not plug or unplug power cords, or turn power or light switches on or off when flammable fumes are present. • Ground all equipment in the work area. See Grounding instructions. • Use only grounded hoses. • Hold gun firmly to side of grounded pail when triggering into pail. • If there is static sparking or you feel a shock, stop operation immediately. Do not use equipment until you identify and correct the problem. • Keep a working fire extinguisher in the work area.
	<p>SKIN INJECTION HAZARD</p> <p>High-pressure fluid from gun, hose leaks, or ruptured components will pierce skin. This may look like just a cut, but it is a serious injury that can result in amputation. Get immediate surgical treatment.</p> <ul style="list-style-type: none"> • Do not point gun at anyone or at any part of the body. • Do not put your hand over the spray tip. • Do not stop or deflect leaks with your hand, body, glove, or rag. • Do not spray without tip guard and trigger guard installed. • Engage trigger lock when not spraying. • Follow Pressure Relief Procedure in this manual, when you stop spraying and before cleaning, checking, or servicing equipment.
	<p>EQUIPMENT MISUSE HAZARD</p> <p>Misuse can cause death or serious injury.</p> <ul style="list-style-type: none"> • Do not operate the unit when fatigued or under the influence of drugs or alcohol. • Do not exceed the maximum working pressure or temperature rating of the lowest rated system component. See Technical Data in all equipment manuals. • Use fluids and solvents that are compatible with equipment wetted parts. See Technical Data in all equipment manuals. Read fluid and solvent manufacturer's warnings. For complete information about your material, request MSDS forms from distributor or retailer. • Check equipment daily. Repair or replace worn or damaged parts immediately with genuine manufacturer's replacement parts only. • Do not alter or modify equipment. • Use equipment only for its intended purpose. Call your distributor for information. • Route hoses and cables away from traffic areas, sharp edges, moving parts, and hot surfaces. • Do not kink or over bend hoses or use hoses to pull equipment. • Keep children and animals away from work area. • Comply with all applicable safety regulations.

 WARNING	
	<p>MOVING PARTS HAZARD</p> <p>Moving parts can pinch or amputate fingers and other body parts.</p> <ul style="list-style-type: none"> • Keep clear of moving parts. • Do not operate equipment with protective guards or covers removed. • Pressurized equipment can start without warning. Before checking, moving, or servicing equipment, follow the Pressure Relief Procedure in this manual. Disconnect power or air supply.
	<p>TOXIC FLUID OR FUMES HAZARD</p> <p>Toxic fluids or fumes can cause serious injury or death if splashed in the eyes or on skin, inhaled, or swallowed.</p> <ul style="list-style-type: none"> • Read MSDS's to know the specific hazards of the fluids you are using. • Store hazardous fluid in approved containers, and dispose of it according to applicable guidelines. • Always wear impervious gloves when spraying or cleaning equipment.
	<p>PERSONAL PROTECTIVE EQUIPMENT</p> <p>You must wear appropriate protective equipment when operating, servicing, or when in the operating area of the equipment to help protect you from serious injury, including eye injury, inhalation of toxic fumes, burns, and hearing loss. This equipment includes but is not limited to:</p> <ul style="list-style-type: none"> • Protective eyewear • Clothing and respirator as recommended by the fluid and solvent manufacturer • Gloves • Hearing protection

Repair

Pressure Relief Procedure

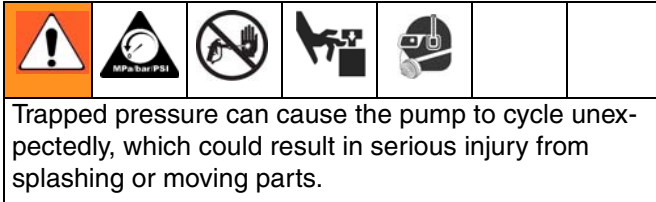

1. Engage the trigger lock.
2. Shutoff the pump:
 - a. *For air-powered pumps*, close the bleed-type master air valve.
 - b. *For hydraulic-powered pumps*, close the supply line shutoff valve first, then close the return line shutoff valve.
3. Disengage the trigger lock.
4. Hold a metal part of the gun firmly to a grounded metal pail. Trigger the gun to relieve pressure.
5. Engage the trigger lock.
6. Open all fluid drain valves in the system, having a waste container ready to catch drainage. Leave drain valve(s) open until you are ready to spray again.
7. If you suspect the spray tip or hose is clogged or that pressure has not been fully relieved after following the steps above, **VERY SLOWLY** loosen tip guard retaining nut or hose end coupling to relieve pressure gradually, then loosen completely. Clear hose or tip obstruction.

Required Tools

- Set of adjustable wrenches
- Large pipe wrench
- 2-5/8 in. wrench
- Torque wrench
- Rubber mallet
- O-ring pick
- Large vise
- Thread lubricant
- Thread sealant

Disassembly

Lay out all the removed parts in sequence, to ease reassembly.

 Packing Repair Kits are available. For the best results, use all the new parts in the kit. Kit parts are marked with an asterisk, for example (3*). These kits can also be used to convert the lower to different packing materials. See pages 14-17.

1. Flush the pump, if possible. Stop the pump at the bottom of its stroke. Relieve the pressure, page 5.
2. Disconnect the lower from the motor. See your separate pump assembly manual.
3. Place the lower lengthwise in a large vise, with the jaws on the outlet housing (7) as shown in FIG. 1, or on the cylinder (8) flats. Loosen, but do not remove, the packing nut (2).
4. Unscrew the intake valve (18). Be careful to catch the intake ball (17) as you remove the intake valve so it does not fall and suffer damage. Remove the seal (30). Inspect the ball and seat (D) for wear or damage.

5. Unscrew the intake housing (16). The lower assembly may separate at joint A or joint B.

CAUTION

To reduce the possibility of costly damage to the rod (1) and cylinder (8), always use a rubber mallet to drive the rod out of the cylinder. Never use a hammer to drive the rod.

- **If the assembly separates at joint A:**

- a. Hold the cylinder (8) flats with a wrench and unscrew the intake housing (16).
- b. *For Dura-Flo 900 and 1200 Lowers:* Using a rubber mallet, drive the rod (1) and piston assembly out of the outlet housing (7) and cylinder (8) until the piston comes free. Pull the rod and piston from the cylinder, being careful not to scratch the parts.

For Dura-Flo 600 and 750 Lowers: Turn the cylinder (8) upside down and strike the top of the rod (1) on a plastic or wooden block until the piston comes free. Pull the rod and piston from the cylinder, being careful not to scratch the parts. See the Detail in FIG. 1.

- c. Using a wrench on the cylinder (8) flats, unscrew the cylinder from the outlet housing (7). Remove the cylinder seals (24). Shine a light into the cylinder to inspect the inner surface for scoring or wear. Now go to step 6.

- **If the assembly separates at joint B:**

- a. Unscrew the cylinder (8) and intake housing (16) from the outlet housing (7). Carefully pull the cylinder and intake housing straight out of the outlet housing. The displacement rod (1) and piston assembly will come out with these parts.
- b. Place the intake housing (16) in a vise. Using a wrench on the cylinder (8) flats, unscrew the cylinder. The rod (1) and piston assembly will remain in the cylinder.

- c. *For Dura-Flo 900 and 1200 Lowers:* Using a rubber mallet, drive the rod (1) and piston assembly out of the outlet housing (7) and cylinder (8) until the piston comes free. Pull the rod and piston from the cylinder, being careful not to scratch the parts.

For Dura-Flo 600 and 750 Lowers: Turn the cylinder (8) upside down and strike the top of the rod (1) on a plastic or wooden block until the piston comes free. Pull the rod and piston from the cylinder, being careful not to scratch the parts. See the Detail in FIG. 1.

- d. Remove the cylinder seals (24). Shine a light into the cylinder to inspect the inner surface for scoring or wear. Now go to step 6.

6. Place the piston flats (15) in a vise. See FIG. 2.
7. Unscrew the piston ball guide (9) from the piston. Be careful to catch the piston ball (10) as you separate the parts, so it does not fall and suffer damage.
8. Examine the displacement rod (1) for scratches and other damage. **Only if the rod needs replacement,** unscrew it from the piston ball guide (9), using a wrench on the flats of the rod.
9. Remove the piston glands and v-packings (P). Inspect the ball (10), seat (E), and guides (F) on the ball guide for wear or damage.
10. See FIG. 4. Unscrew the packing nut (2). Remove the throat packings (T) from the outlet housing (7).
11. Clean all parts with a compatible solvent and inspect them for wear or damage.

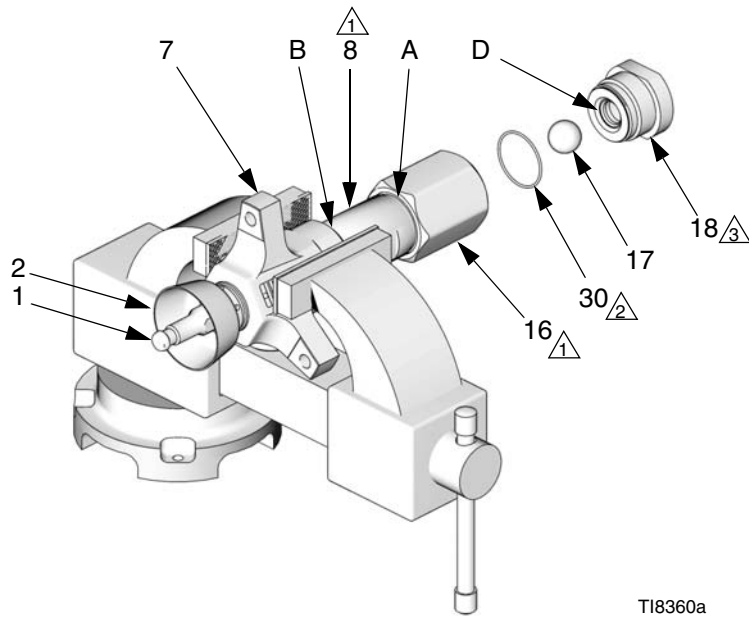

- ⚠️ 1 Torque to 325-353 N•m (240-260 ft-lb).
- ⚠️ 2 Lubricate.
- ⚠️ 3 Torque to 190-217 N•m (140-160 ft-lb).

**Detail
Dura-Flo 600 and 750 Lowers**

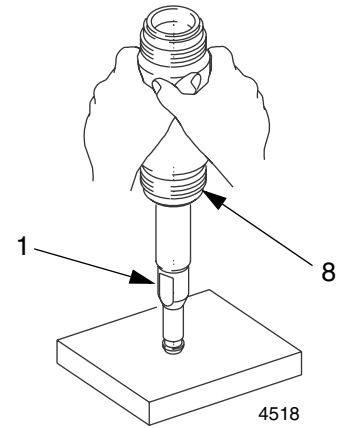
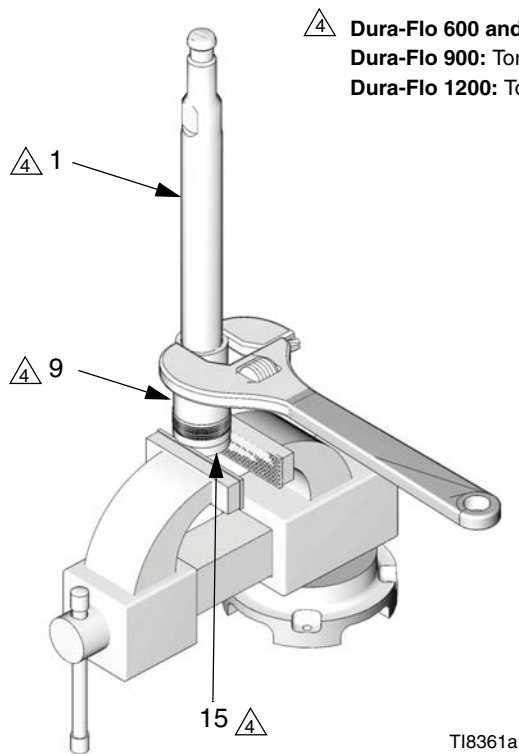

FIG. 1



- ⚠️ 4 **Dura-Flo 600 and 750:** Torque to 258-285 N•m (190-210 ft-lb).
- Dura-Flo 900:** Torque to 271-298 N•m (200-220 ft-lb).
- Dura-Flo 1200:** Torque to 386-407 N•m (285-300 ft-lb).

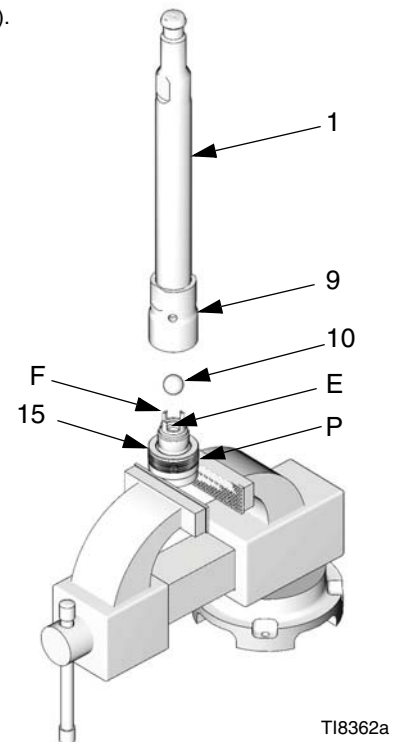



FIG. 2

Reassembly

1. If it was necessary to remove the piston ball guide (9) from the displacement rod (1), clean the threads of the rod and ball guide. Screw the ball housing onto the rod, handtight. Place the flats of the ball guide in a vise and torque as noted in FIG. 4.
2. See FIG. 4. Install the piston packings on the piston (15) in the correct order for your lower, see **Repair Kits**, pages 14-17. Install the v-packings (P) one at a time with the lips facing up.

 To convert the lower to a different packing material, see **Repair Kits**, pages 14-17.

3. See FIG. 2. Place the flats of the piston (15) in a vise. Place the ball (10*) on the piston seat (E). Screw the piston ball guide (9) onto the piston hand tight, then torque as noted.
4. See FIG. 4. Lubricate the throat packings (T). Install the throat packings in the outlet housing (7) in the correct order for your lower, see **Repair Kits**, pages 14-17. Install the v-packings (T) one at a time with the lips facing down.

 To convert the lower to a different packing material, see **Repair Kits**, pages 14-17.

5. Lubricate the threads of the packing nut (2), and loosely install it in the outlet housing (7).

CAUTION

To reduce the possibility of costly damage to the rod (1) and cylinder (8), always use a rubber mallet to drive the rod into the cylinder. Never use a hammer to drive the rod.

6. Lubricate the piston packings (P). Slide the displacement rod (1) and piston assembly down into the cylinder (8). The cylinder is symmetrical, so either end may face up. Use a rubber mallet to drive the rod into the cylinder, until the piston (15) is near the bottom of the cylinder.
7. Install the seal (24*) on the top of the cylinder (8). Lubricate the seal and the top threads of the cylinder.

8. Place the outlet housing (7) in a vise, see FIG. 1. Slide the rod (1) into the housing, then screw the cylinder (8) into the housing handtight. The threads will engage easily until the seal (24*) contacts the sealing surface of the outlet housing. The top of the rod will protrude from the packing nut (2).
9. See FIG. 4. Install the seal (24*) on the bottom of the cylinder (8). Lubricate the seal and the threads of the cylinder. **With the beveled ball stop surfaces (S) facing down**, screw the intake housing (16) onto the cylinder handtight. The threads will engage easily until the seal (24*) contacts the sealing surface of the intake housing.
10. See FIG. 3. Install the seal (30*) on the intake valve (18). Lubricate the seal and the threads of the intake valve. Place the intake ball (17*) in the intake housing (16), then screw the intake valve (18) into the intake housing handtight. The threads will engage easily until the seal (30*) contacts the sealing surface of the intake housing.

 1 Orient so the end with the ball cavity (S, see FIG. 4) faces the ball (17*).

 2 Lubricate.

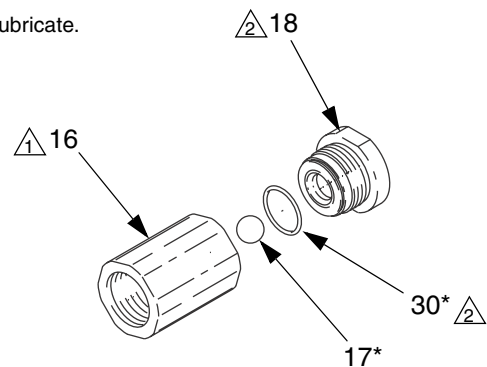

4493a

FIG. 3

11. Torque the intake housing (16) as noted in FIG. 4. This will torque both cylinder joints A and B.
12. Torque the intake valve (18) as noted in FIG. 4.
13. Torque the packing nut (2) as noted in FIG. 4.
14. Reconnect the lower to the motor as explained in your separate pump assembly manual.

- 1 **Dura-Flo 600 and 750:** Torque to 61-75 N•m (45-55 ft-lb).
Dura-Flo 900 and 1200: Torque to 136-149 N•m (100-110 ft-lb).
- 2 Torque to 325-353 N•m (240-260 ft-lb).
- 3 **Dura-Flo 600 and 750:** Torque to 258-285 N•m (190-210 ft-lb).
Dura-Flo 900: Torque to 271-298 N•m (200-220 ft-lb).
Dura-Flo 1200: Torque to 386-407 N•m (285-300 ft-lb).
- 4 Lubricate.
- 5 Lips must face up.
- 6 Lips must face down.
- 7 Torque to 190-217 N•m (140-160 ft-lb).
- 8 **Dura-Flo 600:** Apply thread sealant.

Throat Packings (T)
see Repair Kits, pages 14-17

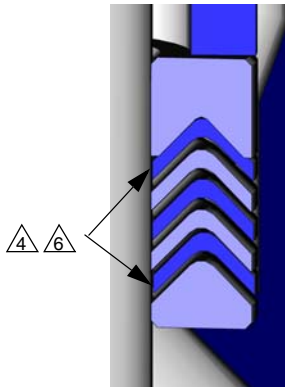

T18389a1

Piston Packings (P)
see Repair Kits, pages 14-17

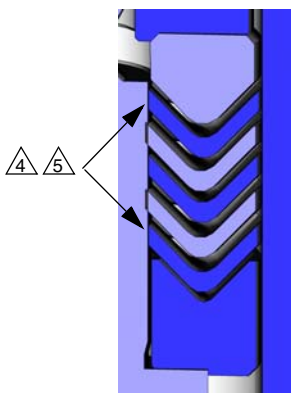

T18389a2

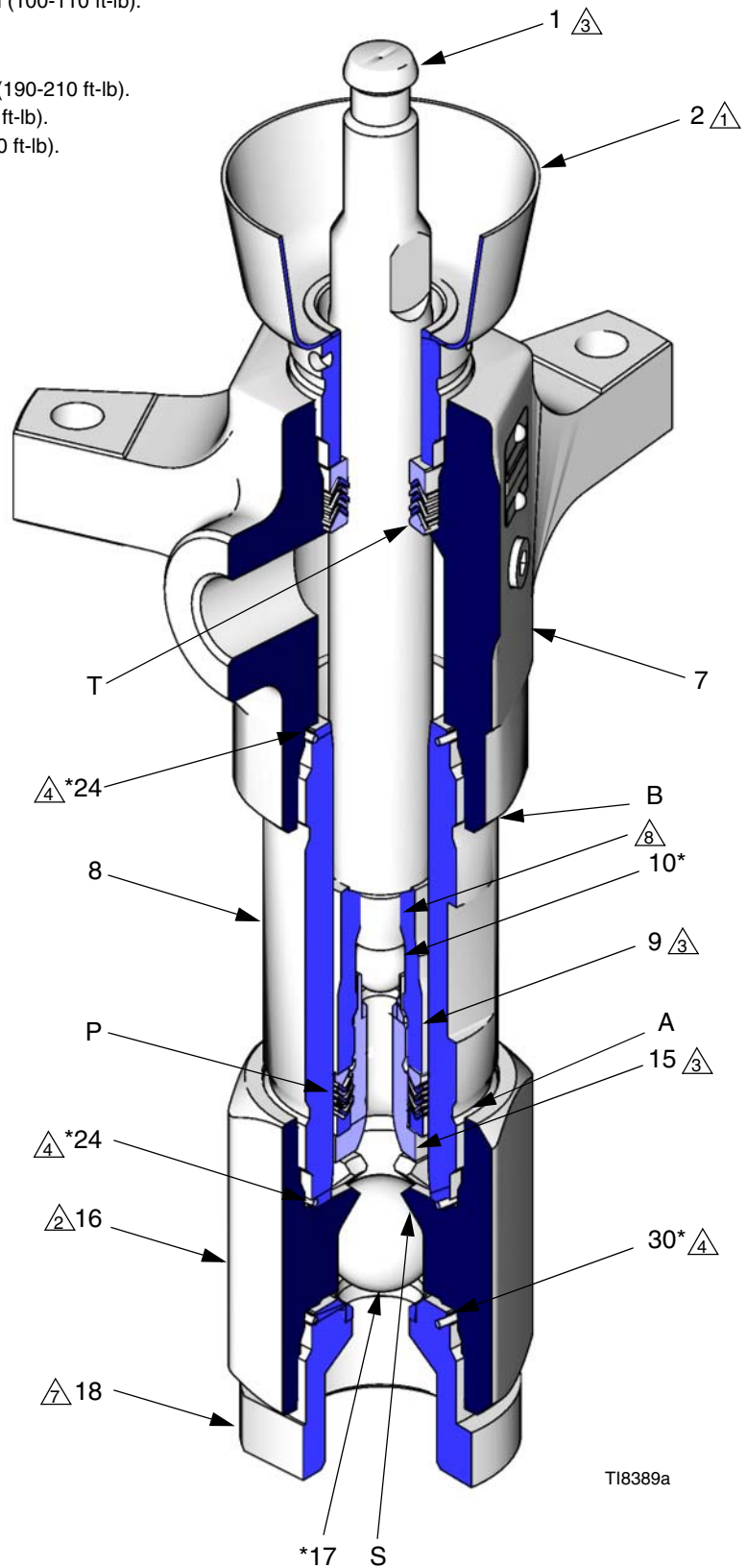

T18389a

FIG. 4

Parts

See the parts listings on pages 11 and 12.

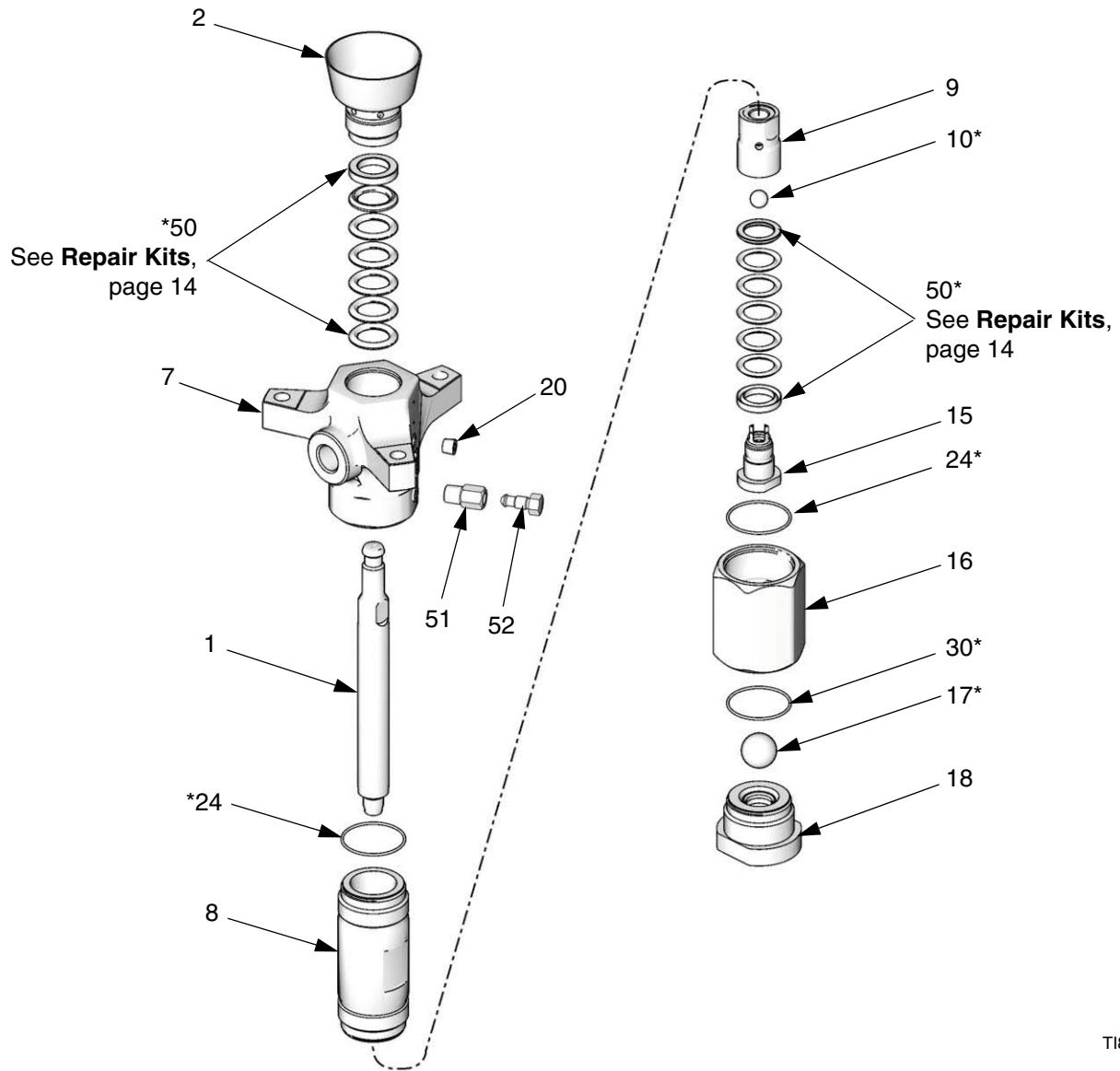

T18342b

Dura-Flo 600 (145 cc) and Dura-Flo 750 (180 cc) Lowers

 See the parts drawing on page 10. Part numbers vary by lower. To find the part number used in your lower, read down the chart to find the desired ref. no., then read left to right to find the part number for your lower.

Ref. No.	Description	Lower Part No.								Qty
		247168 DF 600	236458 DF 600	241177 DF 600	L145SS DF 600	L14BSS DF 600	236456 DF 750	261657 DF 750	L180SS DF 750	
1	ROD, displacement; sst	190172	190172	190172	190172	190172	189853	189853	189853	1
2	PACKING NUT/WET-CUP	236578	236578	236578	236578	236578	236889	236889	236889	1
7	HOUSING, outlet	15H721	189390	189390	189390	15H721	189859	15J646	189859	1
8	CYLINDER	184503	184503	184503	184503	184503	189857	189857	189857	1
9	GUIDE, ball, piston	189406	189406	189406	189406	189406	190497	190497	190497	1
10*	BALL, piston; sst; 5/8 in. (16 mm)	101822	101822	101822	101822	101822				1
	BALL, piston; sst; 3/4 in. (19 mm)						101859	101859	101859	1
15	PISTON; carbide seat	222929	222929	222929	222929	222929	237790	237790	237790	1
16	HOUSING, intake valve	190394	190394	190394	190394	190394	190396	190396	190396	1
17*	BALL, intake; sst; 1.25 in. (31.8 mm)	102973	102973	102973	102973	102973	102973	102973	102973	1
18	VALVE, intake; sst; carbide seat	236585	236585	236585	236585	236585	236585	236585	236585	1
20	PLUG, pipe, socket hd; 3/8 npt; sst	101748	101748	101748			101748	101748		1
23▲	TAG, warning (not shown)	172479	172479	172479	172479	172479	172479	172479	172479	1
24*	SEAL, cylinder; PTFE	109205	109205	109205	109205	109205	166073	166073	166073	2
30*	SEAL, intake valve; PTFE	166073	166073	166073	166073	166073	166073	166073	166073	1
50*	KIT, repair; includes throat and piston packings (see pages 14-17), and items 10, 17, 24, and 30	237234	237234	237609	237609	237609	237240	237240	237608	1
51	HOUSING, valve				184392	184392			184392	1
52	PLUG				190293	190293			190293	1

* Parts included in Repair Kit (purchase separately). See page 14.

▲ Replacement Danger and Warning labels, tags, and cards are available at no cost.

Dura-Flo 900 (220 cc) Lowers

 See the parts drawing on page 10. Part numbers vary by lower. To find the part number used in your lower, read down the chart to find the desired ref. no., then read left to right to find the part number for your lower.

Ref. No.	Description	Lower Part No.						Qty
		247190 DF 900	236470 DF 900	248816 DF 900	236897 DF 900	L220SS DF 900	L22BSS DF 900	
1	ROD, displacement; sst	189316	189316	189316	189316	189316	189316	1
2	PACKING NUT/WET-CUP	236582	236582	236582	236582	236582	236582	1
7	HOUSING, outlet	262516	237182	237182	237182	237182	262516	1
8	CYLINDER	189383	189383	189383	189383	189383	189383	1
9	GUIDE, ball, piston	189408	189408	189408	189408	189408	189408	1
10*	BALL, piston; sst; 3/4 in. (19 mm)	101859	101859	101859	101859	101859	1018529	1
15	PISTON; carbide seat	236587	236587	236587	236587	236587	236587	1
16	HOUSING, intake valve	189396	189396	189396	189396	189396	189396	1
17*	BALL, intake; sst; 1.5 in. (38.1 mm)	108001	108001	108001	108001	108001	108001	1
18	VALVE, intake; sst; carbide seat	236588	236588	236588	236588	236588	236588	1
20	PLUG, pipe, socket hd; 3/8 npt; sst	101748	101748	101748	101748			1
23▲	TAG, warning (not shown)	172479	172479	172479	172479	172479	172479	1
24*	SEAL, cylinder; PTFE	109499	109499	109499	109499	109499	109499	2
30*	SEAL, intake valve; PTFE	109499	109499	109499	109499	109499	109499	1
50*	KIT, repair; includes throat and piston packings (see pages 14-17), and items 10, 17, 24, and 30	237172	237172	See page 16	237173	237710	237710	1
51	HOUSING, valve					184392	184392	1
52	PLUG					190923	190923	1

* Parts included in Repair Kit (purchase separately). See page 14.

▲ Replacement Danger and Warning labels, tags, and cards are available at no cost.

Dura-Flo 1200 (290 cc) Lowers

 See the parts drawing on page 10. Part numbers vary by lower. To find the part number used in your lower, read down the chart to find the desired ref. no., then read left to right to find the part number for your lower.

Ref. No.	Description	Lower Part No.						Qty
		247192 DF 1200	237514 DF 1200	236490 DF 1200	237515 DF 1200	L290SS DF 1200	24B923 DF 1200	
1	ROD, displacement; sst	184487	184487	184487	184487	184487	184487	1
2	PACKING NUT/WET-CUP	236582	236582	236582	236582	236582	236582	1
7	HOUSING, outlet	15H723	237186	237186	237186	237186	237186	1
8	CYLINDER	184540	184540	184540	184540	184540	184540	1
9	GUIDE, ball, piston	189409	189409	189409	189409	189409	189409	1
10*	BALL, piston; sst; 7/8 in. (22.2 mm)	102972	102972	102972	102972	102972	102972	1
15	PISTON; carbide seat	222951	222951	222951	222951	222951	222951	
16	HOUSING, intake valve	189396	189396	189396	189396	189396	189396	1
17*	BALL, intake; sst; 1.5 in. (38.1 mm)	108001	108001	108001	108001	108001	108001	1
18	VALVE, intake; sst; carbide seat	236588	236588	236588	236588	236588	236588	1
20	PLUG, pipe, socket hd; 3/8 npt; sst	101748	101748	101748	101748	101748	101748	1
23▲	TAG, warning (not shown)	172479	172479	172479	172479	172479	172479	1
24*	SEAL, cylinder; PTFE	109499	109499	109499	109499	109499	109499	1
30*	SEAL, intake valve; PTFE	109499	109499	109499	109499	109499	109499	1
50*	KIT, repair; includes throat and piston packings (see pages 14-17), and items 10, 17, 24, and 30	237178	237178	237179	237180	237713	24C162	1

* Parts included in Repair Kit (purchase separately). See page 14.

▲ Replacement Danger and Warning labels, tags, and cards are available at no cost.

Repair Kits

Leather Packings with PTFE Backup

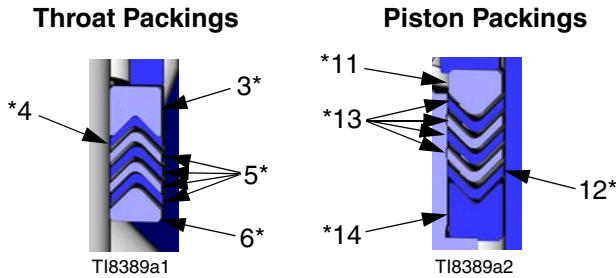

237234 Repair Kit, Dura-Flo 600 Lowers (standard for 247168, 236458)

Ref. No.	Part No.	Description	Qty
3*	184172	GLAND, female, throat; stainless steel	1
4*	109302	V-PACKING, throat; PTFE	1
5*	184302	V-PACKING, throat; leather	4
6*	184222	GLAND, male, throat; stainless steel	1
11*	184222	GLAND, male, piston; stainless steel	1
12*	109302	V-PACKING, piston; PTFE	1
13*	184302	V-PACKING, piston; leather	4
14*	184172	GLAND, female, piston; stainless steel	1

237240 Repair Kit, Dura-Flo 750 Lowers (standard for 236456, 261657)

Ref. No.	Part No.	Description	Qty
3*	184173	GLAND, female, throat; stainless steel	1
4*	109303	V-PACKING, throat; PTFE	1
5*	184303	V-PACKING, throat; leather	4
6*	184223	GLAND, male, throat; stainless steel	1
11*	184223	GLAND, male, piston; stainless steel	1
12*	109303	V-PACKING, piston; PTFE	1
13*	184303	V-PACKING, piston; leather	4
14*	184173	GLAND, female, piston; stainless steel	1

237172 Repair Kit, Dura-Flo 900 Lowers (standard for 247190, 236470)

Ref. No.	Part No.	Description	Qty
3*	184174	GLAND, female, throat; stainless steel	1
4*	109304	V-PACKING, throat; PTFE	1
5*	184304	V-PACKING, throat; leather	4
6*	184224	GLAND, male, throat; stainless steel	1
11*	184225	GLAND, male, piston; stainless steel	1
12*	109305	V-PACKING, piston; PTFE	1
13*	184305	V-PACKING, piston; leather	4
14*	184175	GLAND, female, piston; stainless steel	1

237178 Repair Kit, Dura-Flo 1200 Lowers (standard for 247192, 237514)

Ref. No.	Part No.	Description	Qty
3*	184179	GLAND, female, throat; stainless steel	1
4*	109309	V-PACKING, throat; PTFE	1
5*	184309	V-PACKING, throat; leather	4
6*	184229	GLAND, male, throat; stainless steel	1
11*	184230	GLAND, male, piston; stainless steel	1
12*	109310	V-PACKING, piston; PTFE	1
13*	184310	V-PACKING, piston; leather	4
14*	184180	GLAND, female, piston; stainless steel	1

PTFE Packings

Throat Packings

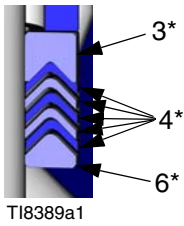

Piston Packings

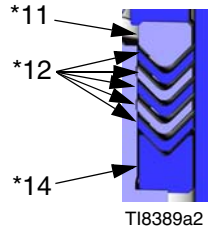

237236 Repair Kit, Dura-Flo 600 Lowers

Ref. No.	Part No.	Description	Qty
3*	184172	GLAND, female, throat; stainless steel	1
4*	109302	V-PACKING, throat; PTFE	5
6*	184222	GLAND, male, throat; stainless steel	1
11*	184222	GLAND, male, piston; stainless steel	1
12*	109302	V-PACKING, piston; PTFE	5
14*	184172	GLAND, female, piston; stainless steel	1

237242 Repair Kit, Dura-Flo 750 Lowers

Ref. No.	Part No.	Description	Qty
3*	184173	GLAND, female, throat; stainless steel	1
4*	109303	V-PACKING, throat; PTFE	5
6*	184223	GLAND, male, throat; stainless steel	1
11*	184223	GLAND, male, piston; stainless steel	1
12*	109303	V-PACKING, piston; PTFE	5
14*	184173	GLAND, female, piston; stainless steel	1

237173 Repair Kit, Dura-Flo 900 Lowers (standard for 236897)

Ref. No.	Part No.	Description	Qty
3*	184174	GLAND, female, throat; stainless steel	1
4*	109304	V-PACKING, throat; PTFE	5
6*	184224	GLAND, male, throat; stainless steel	1
11*	184225	GLAND, male, piston; stainless steel	1
12*	109305	V-PACKING, piston; PTFE	5
14*	184175	GLAND, female, piston; stainless steel	1

237179 Repair Kit, Dura-Flo 1200 Lowers (standard for 236490)

Ref. No.	Part No.	Description	Qty
3*	184179	GLAND, female, throat; stainless steel	1
4*	109309	V-PACKING, throat; PTFE	5
6*	184229	GLAND, male, throat; stainless steel	1
11*	184230	GLAND, male, piston; stainless steel	1
12*	109310	V-PACKING, piston; PTFE	5
14*	184180	GLAND, female, piston; stainless steel	1

24F547 Repair Kit, Dura-Flo 1200 Lowers

Ref. No.	Part No.	Description	Qty
3*	184179	GLAND, female, throat; stainless steel	1
4*	109334	V-PACKING, throat; CF-PTFE	5
6*	184229	GLAND, male, throat; stainless steel	1
11*	184230	GLAND, male, piston; stainless steel	1
12*	109335	V-PACKING, piston; CF-PTFE	5
14*	184180	GLAND, female, piston; stainless steel	1

UHMWPE and PTFE Packings

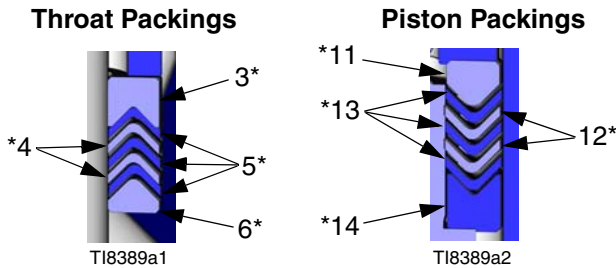

237609 Repair Kit, Dura-Flo 600 Lower (standard for 241177, L145SS, L14BSS)

Ref. No.	Part No.	Description	Qty
3*	184172	GLAND, female, throat; stainless steel	1
4*	109302	V-PACKING, throat; PTFE	2
5*	109252	V-PACKING, throat; UHMWPE	3
6*	184222	GLAND, male, throat; stainless steel	1
11*	184222	GLAND, male, piston; stainless steel	1
12*	109302	V-PACKING, piston; PTFE	2
13*	109252	V-PACKING, piston; UHMWPE	3
14*	184172	GLAND, female, piston; stainless steel	1

237608 Repair Kit, Dura-Flo 750 Lower (standard for L180SS)

Ref. No.	Part No.	Description	Qty
3*	184173	GLAND, female, throat; stainless steel	1
4*	109303	V-PACKING, throat; PTFE	2
5*	109253	V-PACKING, throat; UHMWPE	3
6*	184223	GLAND, male, throat; stainless steel	1
11*	184223	GLAND, male, piston; stainless steel	1
12*	109303	V-PACKING, piston; PTFE	2
13*	109253	V-PACKING, piston; UHMWPE	3
14*	184173	GLAND, female, piston; stainless steel	1

237710 Repair Kit, Dura-Flo 900 Lower (standard for L220SS, L22BSS)

Ref. No.	Part No.	Description	Qty
3*	184174	GLAND, female, throat; stainless steel	1
4*	109304	V-PACKING, throat; PTFE	2
5*	109254	V-PACKING, throat; UHMWPE	3
6*	184224	GLAND, male, throat; stainless steel	1
11*	184225	GLAND, male, piston; stainless steel	1
12*	109305	V-PACKING, piston; PTFE	2
13*	109255	V-PACKING, piston; UHMWPE	3
14*	184175	GLAND, female, piston; stainless steel	1

237713 Repair Kit, Dura-Flo 1200 Lower (standard for L290SS)

Ref. No.	Part No.	Description	Qty
3*	184179	GLAND, female, throat; stainless steel	1
4*	109309	V-PACKING, throat; PTFE	2
5*	109259	V-PACKING, throat; UHMWPE	3
6*	184229	GLAND, male, throat; stainless steel	1
11*	184230	GLAND, male, piston; stainless steel	1
12*	109310	V-PACKING, piston; PTFE	2
13*	109260	V-PACKING, piston; UHMWPE	3
14*	184180	GLAND, female, piston; stainless steel	1

24C162 Repair Kit, Dura-Flo 1200 Lower (standard for 24B923)

Ref. No.	Part No.	Description	Qty
3*	184179	GLAND, female, throat; stainless steel	1
4*	109334	V-PACKING, throat; CF-PTFE	2
5*	109259	V-PACKING, throat; UHMWPE	3
6*	184229	GLAND, male, piston; stainless steel	1
11*	184230	GLAND, male, piston; stainless steel	1
12*	109335	V-PACKING, piston; CF-PTFE	2
13*	109260	V-PACKING, piston; UHMWPE	3
14*	184180	GLAND, female, piston; stainless steel	1

For Part No. 248816 Dura-Flo 900 Lower

Throat Packings Piston Packings

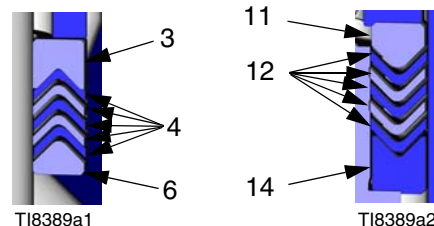

Ref. No.	Part No.	Description	Qty
3*	184174	GLAND, female, throat; stainless steel	1
4*	109254	V-PACKING, throat; UHMWPE	5
6*	184224	GLAND, male, throat; stainless steel	1
11*	184225	GLAND, male, piston; stainless steel	1
12*	109305	V-PACKING, piston; PTFE	5
14*	184175	GLAND, female, piston; stainless steel	1

UHMWPE and Leather Packings

Throat Packings

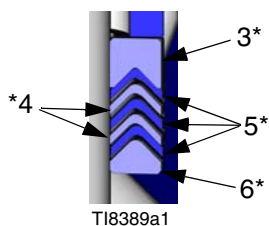

Piston Packings

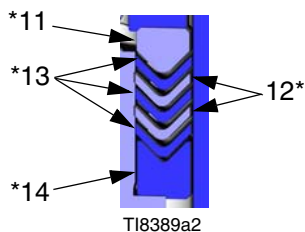

237238 Repair Kit, Dura-Flo 600 Lowers

Ref. No.	Part No.	Description	Qty
3*	184172	GLAND, female, throat; stainless steel	1
4*	184302	V-PACKING, throat; leather	2
5*	109252	V-PACKING, throat; UHMWPE	3
6*	184222	GLAND, male, throat; stainless steel	1
11*	184222	GLAND, male, piston; stainless steel	1
12*	184302	V-PACKING, piston; leather	2
13*	109252	V-PACKING, piston; UHMWPE	3
14*	184172	GLAND, female, piston; stainless steel	1

237244 Repair Kit, Dura-Flo 750 Lowers

Ref. No.	Part No.	Description	Qty
3*	184173	GLAND, female, throat; stainless steel	1
4*	184303	V-PACKING, throat; leather	2
5*	109253	V-PACKING, throat; UHMWPE	3
6*	184223	GLAND, male, throat; stainless steel	1
11*	184223	GLAND, male, piston; stainless steel	1
12*	184303	V-PACKING, throat; leather	2
13*	109253	V-PACKING, piston; UHMWPE	3
14*	184173	GLAND, female, piston; stainless steel	1

237174 Repair Kit, Dura-Flo 900 Lowers

Ref. No.	Part No.	Description	Qty
3*	184174	GLAND, female, throat; stainless steel	1
4*	184304	V-PACKING, throat; leather	2
5*	109254	V-PACKING, throat; UHMWPE	3
6*	184224	GLAND, male, throat; stainless steel	1
11*	184225	GLAND, male, piston; stainless steel	1
12*	184305	V-PACKING, piston; leather	2
13*	109255	V-PACKING, piston; UHMWPE	3
14*	184175	GLAND, female, piston; stainless steel	1

237180 Repair Kit, Dura-Flo 1200 Lowers (standard for 237515)

Ref. No.	Part No.	Description	Qty
3*	184179	GLAND, female, throat; stainless steel	1
4*	184309	V-PACKING, throat; leather	2
5*	109259	V-PACKING, throat; UHMWPE	3
6*	184229	GLAND, male, throat; stainless steel	1
11*	184230	GLAND, male, piston; stainless steel	1
12*	184310	V-PACKING, piston; leather	2
13*	109260	V-PACKING, piston; UHMWPE	3
14*	184180	GLAND, female, piston; stainless steel	1

Technical Data

Maximum fluid working pressure See **Graco Information 20**, page 2.
Lower effective area Dura-Flo 600 (145 cc): 6 cm² (0.93 in.²)
Dura-Flo 750 (180 cc): 7.5 cm² (1.16 in.²)
Dura-Flo 900 (220 cc): 9 cm² (1.40 in.²)
Dura-Flo 1200 (290 cc): 12 cm² (1.86 in.²)
Wetted parts 304, 316, 440, and 17-4 PH grades of stainless steel, tungsten carbide, PTFE, glass-filled PTFE

Packing materials: See **Repair Kits**, pages 14-17.

Dimensions

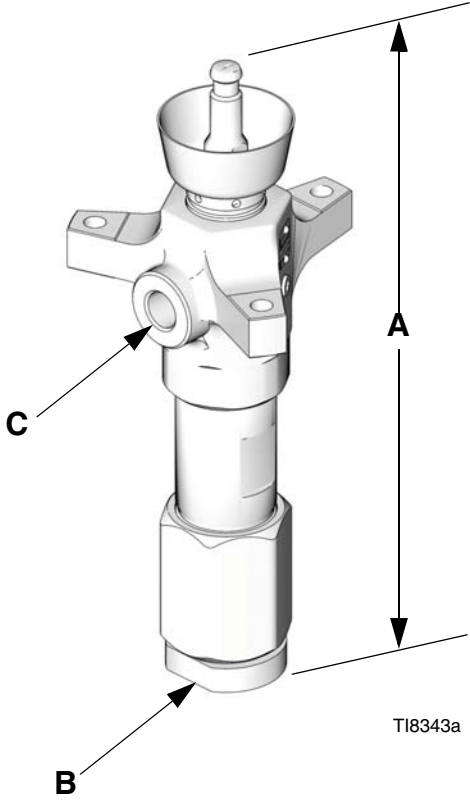

Lower Model	A mm (in.)	B	C	Weight kg (lb)
Dura-Flo 600	485 (19.1)	1-1/2 in. npt(f)	3/4 npt(f)	13 (29)
Dura-Flo 750	485 (19.1)	1-1/2 in. npt(f)	3/4 npt(f)	14 (30)
Dura-Flo 900	516 (20.3)	2 in. npt(f)	1 in. npt(f)	29 (63)
Dura-Flo 1200	516 (20.3)	2 in. npt(f)	1 in. npt(f)	29 (63)

Graco Standard Warranty

Graco warrants all equipment referenced in this document which is manufactured by Graco and bearing its name to be free from defects in material and workmanship on the date of sale to the original purchaser for use. With the exception of any special, extended, or limited warranty published by Graco, Graco will, for a period of twelve months from the date of sale, repair or replace any part of the equipment determined by Graco to be defective. This warranty applies only when the equipment is installed, operated and maintained in accordance with Graco's written recommendations.

This warranty does not cover, and Graco shall not be liable for general wear and tear, or any malfunction, damage or wear caused by faulty installation, misapplication, abrasion, corrosion, inadequate or improper maintenance, negligence, accident, tampering, or substitution of non-Graco component parts. Nor shall Graco be liable for malfunction, damage or wear caused by the incompatibility of Graco equipment with structures, accessories, equipment or materials not supplied by Graco, or the improper design, manufacture, installation, operation or maintenance of structures, accessories, equipment or materials not supplied by Graco.

This warranty is conditioned upon the prepaid return of the equipment claimed to be defective to an authorized Graco distributor for verification of the claimed defect. If the claimed defect is verified, Graco will repair or replace free of charge any defective parts. The equipment will be returned to the original purchaser transportation prepaid. If inspection of the equipment does not disclose any defect in material or workmanship, repairs will be made at a reasonable charge, which charges may include the costs of parts, labor, and transportation.

THIS WARRANTY IS EXCLUSIVE, AND IS IN LIEU OF ANY OTHER WARRANTIES, EXPRESS OR IMPLIED, INCLUDING BUT NOT LIMITED TO WARRANTY OF MERCHANTABILITY OR WARRANTY OF FITNESS FOR A PARTICULAR PURPOSE.

Graco's sole obligation and buyer's sole remedy for any breach of warranty shall be as set forth above. The buyer agrees that no other remedy (including, but not limited to, incidental or consequential damages for lost profits, lost sales, injury to person or property, or any other incidental or consequential loss) shall be available. Any action for breach of warranty must be brought within two (2) years of the date of sale.

GRACO MAKES NO WARRANTY, AND DISCLAIMS ALL IMPLIED WARRANTIES OF MERCHANTABILITY AND FITNESS FOR A PARTICULAR PURPOSE, IN CONNECTION WITH ACCESSORIES, EQUIPMENT, MATERIALS OR COMPONENTS SOLD BUT NOT MANUFACTURED BY GRACO. These items sold, but not manufactured by Graco (such as electric motors, switches, hose, etc.), are subject to the warranty, if any, of their manufacturer. Graco will provide purchaser with reasonable assistance in making any claim for breach of these warranties.

In no event will Graco be liable for indirect, incidental, special or consequential damages resulting from Graco supplying equipment hereunder, or the furnishing, performance, or use of any products or other goods sold hereto, whether due to a breach of contract, breach of warranty, the negligence of Graco, or otherwise.

FOR GRACO CANADA CUSTOMERS

The Parties acknowledge that they have required that the present document, as well as all documents, notices and legal proceedings entered into, given or instituted pursuant hereto or relating directly or indirectly hereto, be drawn up in English. Les parties reconnaissent avoir convenu que la rédaction du présente document sera en Anglais, ainsi que tous documents, avis et procédures judiciaires exécutés, donnés ou intentés, à la suite de ou en rapport, directement ou indirectement, avec les procédures concernées.

Graco Information

For the latest information about Graco products, visit www.graco.com.

TO PLACE AN ORDER, contact your Graco distributor or call to identify the nearest distributor.

Phone: 612-623-6921 **or Toll Free:** 1-800-328-0211 **Fax:** 612-378-3505

*All written and visual data contained in this document reflects the latest product information available at the time of publication.
Graco reserves the right to make changes at any time without notice.*

For patent information, see www.graco.com/patents.

Original instructions. This manual contains English. MM 311827

Graco Headquarters: Minneapolis
International Offices: Belgium, China, Japan, Korea

GRACO INC. AND SUBSIDIARIES • P.O. BOX 1441 • MINNEAPOLIS MN 55440-1441 • USA

Copyright 2006, Graco Inc. All Graco manufacturing locations are registered to ISO 9001.

www.graco.com

Revised 18 May 2012