

Triton[®] 3D150 Diaphragm Pump

311688G
ENG

Used to pump waterborne and solvent-based paints and catalysts. For professional use only.

Part No. 253704, Series B

3:1 Ratio Air-operated Double Diaphragm Pump, with BSPP Fittings

Part No. 253705, Series B

3:1 Ratio Air-operated Double Diaphragm Pump, with NPT Fittings

100 psi (0.7 MPa, 7 bar) Maximum Air Input Pressure

300 psi (2.1 MPa, 21 bar) Maximum Fluid Working Pressure



Important Safety Instructions

Read all warnings and instructions in this manual.
Save these instructions.

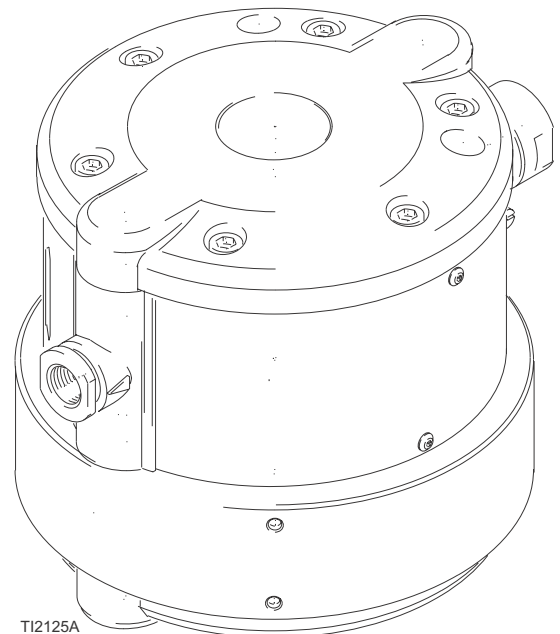









Contents

Warning	3
Installation	5
General Information	5
Tightening Threaded Fasteners Before First Use	5
Mounting the Pump	6
Air Line	7
Fluid Suction Line	7
Fluid Outlet Line	7
Grounding	9
Operation	10
Pressure Relief Procedure	10
Flushing the Pump Before First Use	10
Starting and Adjusting the Pump	10
Pump Shutdown	10
Maintenance	11
Lubrication	11
Flushing and Storage	11
Tightening Threaded Connections	11
Preventive Maintenance Schedule	11
Troubleshooting	12
Repair	13
Prepare the Pump for Repair	13
General Repair Notes	13
Fault Indications	13
Tools Required	13
Replace the Diaphragms	14
Repair the Air Valve	16
Repair the Shaft and Bearings	18
Replace the Ball Check Valves	20
Parts	22
Technical Data	24
Performance Chart	25
Dimensions	26
Graco Standard Warranty	28
Graco Information	28

Warnings

The following warnings are for the setup, use, grounding, maintenance, and repair of this equipment. The exclamation point symbol alerts you to a general warning and the hazard symbol refers to procedure-specific risk. Refer back to these warnings. Additional, product-specific warnings may be found throughout the body of this manual where applicable.

 Warning	
	<p>EQUIPMENT MISUSE HAZARD</p> <p>Equipment misuse can cause the equipment to rupture or malfunction and result in serious injury.</p> <ul style="list-style-type: none"> • This equipment is for professional use only. • Read all instruction manuals, tags, and labels before operating the equipment. • Use the equipment only for its intended purpose. If you are not sure, call your Graco distributor. • Do not alter or modify this equipment. Use only genuine Graco parts and accessories. • Check equipment daily. Repair or replace worn or damaged parts immediately. • Do not exceed the maximum working pressure of the lowest rated system component. Refer to the Technical Data on page 24 for the maximum working pressure of this equipment. • Use fluids and solvents which are compatible with the equipment wetted parts. Refer to the Technical Data section of all equipment manuals. Read the fluid and solvent manufacturer's warnings. • Do not use hoses to pull equipment. • Route hoses away from traffic areas, sharp edges, moving parts, and hot surfaces. Do not expose Graco hoses to temperatures above 82°C (180°F) or below -40°C (-40°F). • Wear hearing protection when operating this equipment. • Comply with all applicable local, state, and national fire, electrical, and safety regulations.
	<p>PRESSURIZED EQUIPMENT HAZARD</p> <p>Spray from the gun, hose leaks, or ruptured components can splash fluid in the eyes or on the skin and cause serious injury.</p> <ul style="list-style-type: none"> • Do not point the gun at anyone or at any parts of the body. • Do not stop or deflect leaks with your hand, body, glove, or rag. • Follow the Pressure Relief Procedure on page 10 whenever you are instructed to relieve pressure; stop spraying; clean, check, or repair the equipment; and install or clean the spray nozzle. • Tighten all fluid connections before operating the equipment. • Check the hoses, tubes, and couplings daily. Replace worn, damaged, or loose parts immediately. Permanently coupled hoses cannot be repaired; replace the entire hose.
	<p>FIRE AND EXPLOSION HAZARD</p> <p>Improper grounding, poor ventilation, open flames or sparks can cause a hazardous condition and result in a fire or explosion and serious injury.</p> <ul style="list-style-type: none"> • Ground the equipment and the object being sprayed. Refer to Grounding on page 9. • If there is any static sparking or you feel an electric shock while using this equipment, stop the equipment immediately. Do not use the equipment until you identify and correct the problem. • Provide fresh air ventilation to avoid the buildup of flammable fumes from solvents or the fluid being sprayed. • Keep the work area free of debris, including solvent, rags, and gasoline. • Eliminate all ignition sources such as pilot lights, cigarettes, and static arcs from plastic drop cloths. Do not plug in or unplug power cords or turn lights on or off in the spray area.

 Warning	
	<p>TOXIC FLUID HAZARD</p> <p>Hazardous fluid or toxic fumes can cause serious injury or death if splashed in the eyes or on the skin, inhaled, or swallowed.</p> <ul style="list-style-type: none"> • Know the specific hazards of the fluid you are using. • Store hazardous fluid in an approved container. Dispose of hazardous fluid according to all local, state and national guidelines. • Always wear protective eyewear, gloves, clothing and respirator as recommended by the fluid and solvent manufacturer. • If a diaphragm fails, fluid is exhausted along with the air. When pumping hazardous fluids, place the pump in an appropriate container to catch the fluid if a diaphragm ruptures.
	<p>MOVING PARTS HAZARD</p> <p>Moving parts, such as the diaphragm shaft, can pinch or amputate your fingers.</p> <ul style="list-style-type: none"> • Before servicing the equipment, follow the Pressure Relief Procedure on page 10 to prevent the equipment from starting unexpectedly.
	<p>PERSONAL PROTECTIVE EQUIPMENT</p> <p>You must wear appropriate protective equipment when operating, servicing, or when in the operating area of the equipment to help protect you from serious injury, including eye injury, inhalation of toxic fumes, burns, and hearing loss. This equipment includes but is not limited to:</p> <ul style="list-style-type: none"> • Protective eyewear • Clothing and respirator as recommended by the fluid and solvent manufacturer • Gloves • Hearing protection

Installation

General Information

- FIG. 2 is only a guide for installing system components and accessories. It is not an actual system design. Contact your Graco distributor for assistance in designing a system to suit your particular needs.
- Always use Genuine Graco Parts and Accessories, available from your Graco distributor. If you supply your own accessories, be sure they are adequately sized and pressure-rated for your system.
- Reference numbers and letters in parentheses refer to the reference numbers in the figures and the parts list on page 22.

Tightening Threaded Fasteners Before First Use

NOTE: Before using pump, loosen fluid cover screws (38) 1-2 turns and then retorque to 13.6 N•m (10 ft-lb).

See the **Repair** section for torque specifications.

- After unpacking the pump and before using it for the first time, check and retorque all diaphragm cover bolts (38, 39).
- After the first day of operation, retorque the fasteners again.
- As a general guideline, retorque fasteners every two months.

Mounting the Pump

- For ease of operation and service, mount the pump so the air inlet, fluid inlet, and fluid outlet ports are easily accessible.
- Mount the pump in a well-ventilated area with sufficient clearance on all sides for operator access and servicing.
- The pump must be mounted horizontally as shown in FIG. 1. Be sure that the pump is level in all directions and that the cylinder housing (54) is positioned on the bottom. See FIG. 1.
- The pump can be floor mounted or mounted on a wall using mounting kit 246495.
- Be sure the mounting can support the weight of the pump, hoses, and accessories as well as the stress caused during operation. The pump has two mounting holes for 0.31 in. (8 mm) screws. See the Dimension drawing on page 26.

Wall mount using kit 246495:

1. Use the bracket (15C022) as a template to drill 2 0.38 (9.6 mm) diameter holes in the wall.
2. Loosely attach bracket (15C022) to the wall with anchors and screws (8 mm) long enough to prevent the bracket from vibrating during operation.
3. Remove bracket from the wall and fasten it to the pump using the 4 screws (116899) and 1 lock washer (100028) included in the kit.
4. The lock washer must be used in the unpainted hole to ensure proper grounding of the bracket.
5. Mount the bracket with the pump attached to the wall and tighten.

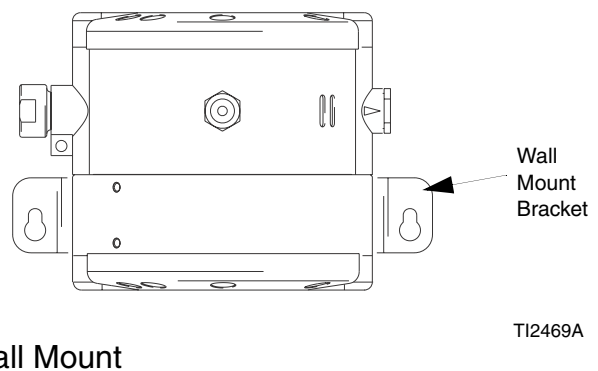
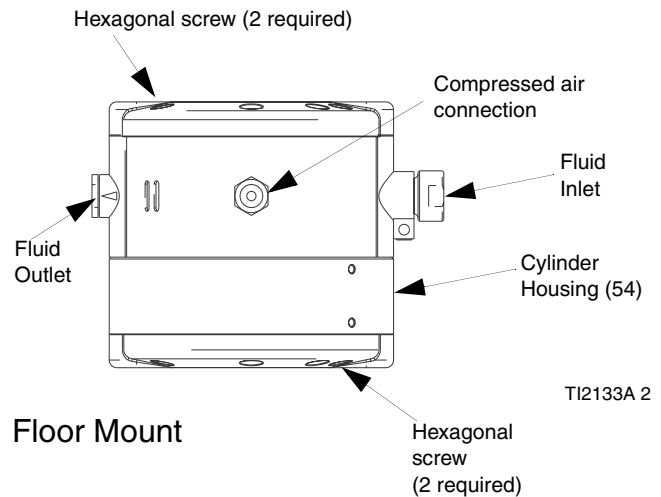

FIG. 1. Mounting the Pump

Air Line

1. Install the air line accessories as shown in FIG. 2. Be sure the air line supplying the accessories is grounded.
 - a. The fluid pressure can be controlled with either an air regulator (F) to control the air into the pump, or with a fluid regulator (H) to control the fluid out of the pump.
 - b. Install a bleed-type master air valve (B) close to the pump. This valve is required in your system to relieve air trapped between it and the pump when the valve is closed. Trapped air can cause the pump to cycle unexpectedly which could result in serious injury including splashing in the eyes or on the skin, or injury from moving parts. Be sure the bleed valve is easily accessible from the pump, and is located downstream from the air regulator.
 - c. Install a second air valve (E) upstream from all air line accessories to isolate them during cleaning and repair.
 - d. Install an air line filter (D) to remove contaminants such as dirt, moisture, and oil from the compressed air supply.
2. The air valve does not require lubrication.
3. Install a grounded, flexible air hose between the accessories and the pump air inlet. See **Technical Data** on page 24 to determine the air inlet size of your pump. Use a minimum 1/2 in. (13 mm) ID air hose.



Fluid Suction Line

- See **Technical Data** on page 24 to determine the fluid inlet size of your pump.
- Use conductive hoses (see FIG. 2). Screw the suction line into the pump inlet snugly while supporting the inlet with a wrench. Use a compatible liquid thread sealant on connections to prevent air from entering the fluid line.

- For maximum suction lift (wet and dry) information, see **Technical Data** on page 24.
- Use an agitator to prevent fluid from settling out. Part number 245081 Agitator Kit (accessory) is available.

Fluid Outlet Line

1. Use electrically conductive fluid hoses (P). See FIG. 2. Screw the fluid fitting into the pump outlet (N) snugly while supporting the outlet with a wrench. See **Technical Data** on page 24 to determine the fluid outlet size of your pump.
2. Install a fluid regulator (H) at the pump fluid outlet to control fluid pressure, if desired. See **Air Line** step 1a for an alternative method to control pressure.
3. Install a fluid drain valve (J) near the fluid outlet.

						
<p>A fluid drain (J) valve is required in your system to relieve pressure in the hose if it is plugged. The drain valve reduces the risk of serious injury, including splashing in the eyes or on the skin, or contamination from hazardous fluids when relieving pressure. Install the valve close to the pump fluid outlet. To use the valve as a circulation valve, connect a tube (K) between the valve and pail.</p>						

CAUTION

Some systems may require installation of a pressure relief valve at the pump outlet to prevent overpressurization and rupture of the pump or hose.

Thermal expansion of fluid in the outlet line can cause overpressurization. This can occur when using long fluid lines exposed to sunlight or ambient heat, or when pumping from a cool to a warm area (for example, from an underground tank).

Overpressurization can also occur if the pump is being used to feed fluid to a piston pump and the intake valve of the piston pump does not close, causing fluid to back up in the outlet line.

Key:

- A TRITON 3D150 Pump
- B Bleed-type master air valve (required for pump)
- C Air supply line
- D Air line filter
- E Air line shutoff valve
- F Pump air regulator
- G Gun air regulator (used in spray system only)
- H Fluid pressure regulator (used in spray system only)
- J Drain/circulation valve
- K Drain tube
- L Suction tube
- M Pump fluid inlet
- N Pump fluid outlet
- P Fluid hose (shown connected to gun in spray system)
- R Gun air hose (used in spray system only)
- S Spray gun (used in spray system only)
- T Pump air inlet
- U Agitator (used in spray system only)
- W Ground wire

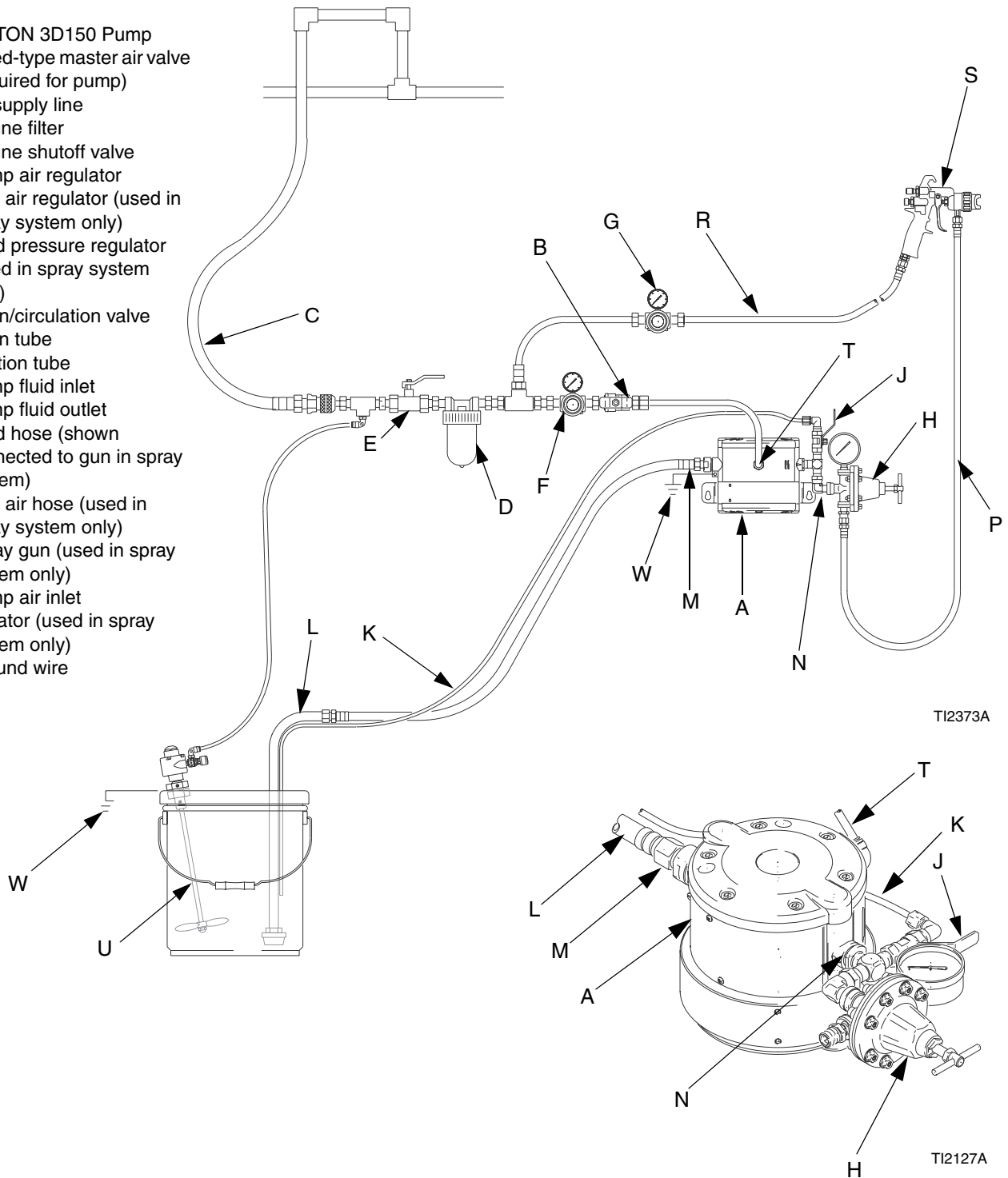

FIG. 2. Typical Installation

Grounding

<p>Before operating the pump, ground the system as explained below. Read the warnings on page 3.</p>						

Ground all of this equipment:

- *Pump:* use a ground wire and clamp. See FIG. 3. Loosen the grounding screw (X). Insert one end of a 12 ga (1.5 mm²) minimum ground wire (Y) under the clamp and tighten the screw securely. Connect the other end of the wire to a true earth ground. For a ground wire and clamp, order Part No. 222011.
- *Air and fluid hoses:* Use only electrically conductive hoses.
- *Air compressor:* Follow manufacturer's recommendations.
- *Fluid supply drum:* Follow your local code.

- *All fluid pails used when flushing:* Follow your local code. Use only conductive metal pails placed on a grounded surface. Do not place the pail on a non-conductive surface, such as paper or cardboard, which interrupts the grounding continuity.

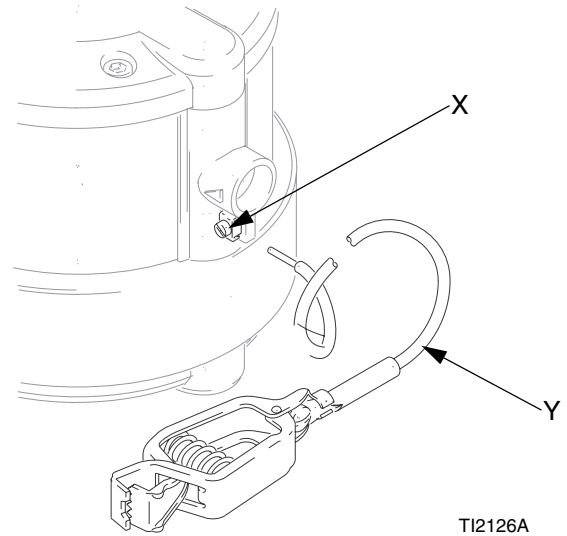





FIG. 3. Grounding the Pump

Operation

Pressure Relief Procedure

						
<p>Read the warnings on page 3, and follow the Pressure Relief procedure below whenever you:</p> <ul style="list-style-type: none"> • are instructed to relieve pressure • stop spraying • check or service any of the equipment • install or clean the fluid nozzle. 						

1. Shut off the air to the pump.
2. Open the dispensing valve, if used.
3. Open the fluid drain valve to relieve all fluid pressure, having a container ready to catch the drainage.

Flushing the Pump Before First Use

The pump was tested in oil. If oil could contaminate the fluid you are pumping, flush the pump thoroughly with a compatible flushing fluid. Follow the steps under **Starting and Adjusting the Pump**.

Starting and Adjusting the Pump

1. Be sure the pump is properly grounded. Refer to **Grounding** on page 9.
2. Check all fittings to be sure they are tight. Be sure to use a compatible liquid thread sealant on all male threads. Re-torque diaphragm cover bolts (38, 39) before start-up.
3. Place the suction tube (L) in the fluid to be pumped.
4. Place the end of the fluid hose (P), see FIG. 2, into an appropriate container.
5. Close the fluid drain valve (J).
6. With the pump air regulator (F) closed, open the bleed-type master air valve (B).

7. If the fluid hose has a dispensing device, hold it open while continuing with the following step.
8. Slowly open the air regulator (F) until the pump starts to cycle. Allow the pump to cycle slowly until all air is pushed out of the lines and the pump is primed.

If you are flushing, run the pump long enough to thoroughly clean the pump and hoses. Close the air regulator. Remove the suction tube (L) from compatible flushing fluid and place it in the fluid to be pumped.

 Operating the pump dry for extended periods or operating at pressures higher than the recommended maximum input air pressure will reduce diaphragm life.

Pump Shutdown

Short Term Shutdown

For a short term shutdown, relieve the pressure (see procedure on this page).

Long Term Shutdown

For a long term shutdown, such as several hours or overnight:

1. Flush the pump thoroughly.
2. Leave compatible flushing fluid in the pump.
3. Relieve the pressure (see procedure on this page).

Maintenance

Lubrication

CAUTION
Lubrication of the pump is not required. Oil is exhausted through the muffler, which could contaminate the fluid supply or other equipment. Excessive lubrication can also cause the pump to malfunction.

Flushing and Storage

Flush the pump often enough to prevent the fluid you are pumping from curing, drying, or freezing in the pump and damaging it. Follow the **Pressure Relief Procedure** on page 10 before storing it for any length of time. Use a compatible flushing fluid.

Tightening Threaded Connections

1. Before each use, check all hoses for wear or damage, and replace as necessary.
2. Check to be sure all threaded connections are tight and leak-free.
3. Check and re-torque all screws and fasteners at least every two months.

Preventive Maintenance Schedule

- Establish a preventive maintenance schedule, based on the service history of the pump. This is especially important for prevention of spills or leakage due to diaphragm failure.

Troubleshooting



Relieve the pressure (page 10) before checking or servicing the equipment.



Check all possible problems and causes before disassembling the pump.

Problem	Cause	Solution
Pump cycles at stall or fails to hold pressure at stall.	Worn check valve balls (26), seats (31), or ball guides (32).	Replace. See page 20.
Pump will not cycle, or cycles once and stops.	Stuck or dirty air valve.	Disassemble and clean air valve. See page 16. Use filtered air.
	Check valve ball (26) severely worn and wedged in seat (31).	Replace ball and seat. See page 20.
	Check valve ball (26) wedged in seat (31) due to overpressurization.	Replace. See page 20. Do not exceed the maximum fluid working pressure, see page 24.
	Clogged fluid dispensing valve.	Relieve pressure and clear valve.
	Pinched hose line.	Check lines.
Pump operates erratically.	Clogged suction line.	Inspect; clear.
	Sticky or leaking check valves.	Clean or replace balls (26) and seats (31). See page 20.
	Ruptured diaphragm (9).	Replace. See page 13.
	Restricted exhaust.	Remove restriction.
Air bubbles in fluid.	Loose suction line.	Tighten.
	Ruptured diaphragm (9).	Replace. See page 13.
Pump running irregularly. Stroke frequency dropping, coming to standstill.	Worn parts.	Replace worn parts. Check compressed air supply.
	Icing caused by: compressed air too moist, stroke frequency too high, local temperature too low.	Remove ice by changing operating conditions.
Air escapes continually.	Damaged air valve cup (15) or seat.	Replace damaged parts. See page 16.
	Foreign matter inside pump.	Check air filter.
Pump does not start, or pressure fluctuates.	Worn check valve seats.	Replace. See page 20.
	Inlet strainer blocked, maximum suction exceeded, hose or seal defective.	Clean strainer. Replace defective parts.
	Contaminated fluid. Pump installed or operated incorrectly.	Check fluid supply. Follow installation and operation instructions in this manual.

Repair

Prepare the Pump for Repair

1. Flush the pump if possible, page 11.
2. Relieve the pressure, page 10.
3. Disconnect the air and fluid hoses.
4. Remove the pump from its mounting and take it to the work bench.

General Repair Notes



- A qualified technician should make all repairs.
- Inspect and clean all parts thoroughly before reassembly.
- Use only genuine Graco replacement parts, available from your Graco distributor.
- Be careful not to damage sealing surfaces.
- Replace all o-rings removed from the pump.
- Follow all lubrication, torque, and repair notes in the repair procedures.
- Do not use silicone or silicone-based grease.

Fault Indications

During operation, check for indications of worn or damaged parts, such as:

- major pressure fluctuations
- change in the pump's operating sound
- irregular operation.

Always replace worn or damaged parts immediately to prevent additional damage.

Tools Required

- 3, 4, and 6 mm allen wrenches
- 12, 19, and 22 mm open end wrenches
- internal snap ring pliers
- o-ring pick
- needlenose pliers
- vise with soft jaws

Replace the Diaphragms

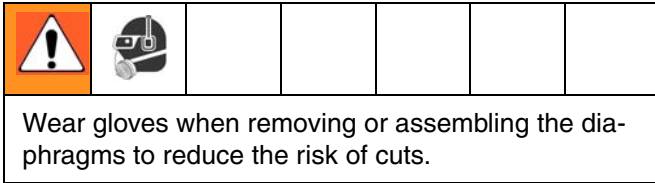

 Diaphragm Repair Kit 246011 is available. Parts included in the kit are marked, for example (9*). For the best results, replace both diaphragms.

Always replace the ball check seals (29) whenever the fluid covers are removed. These seals are included in each of the repair kits.

Disassembly

1. Prepare the pump for repair of the cylinder-side diaphragm.
 - a. Remove the 6 screws (39) and fluid cover (37) from the housing side of the pump.
 - b. Press on the exposed diaphragm (9) to fully extend the cylinder-side diaphragm.
 - c. Replace the housing-side cover and tighten the 6 screws.

 The housing-side cover must be reassembled tightly enough to prevent the shaft from turning when the cylinder-side diaphragm is loosened.

2. Repair the cylinder-side diaphragm.
 - a. Remove the 6 screws (38) and fluid cover (37) from the cylinder side.
 - b. Remove the ball check seals (29).
 - c. The exposed diaphragm should be in the fully extended position (protruding out from the cylinder). If it is not, reassemble the cylinder-side seals and cover and repeat step 1.
 - d. Grip the cylinder-side diaphragm firmly and unscrew it from the rod by hand.
 - e. Install a new diaphragm (9*) firmly, by hand.

3. Prepare the pump for repair of the housing-side diaphragm.
 - a. Press on the cylinder-side diaphragm so that it protrudes into the cylinder. This will fully extend the diaphragm on the housing side.
 - b. Install new ball check seals (29*).
 - c. Replace the fluid cover and install the 6 screws. Torque the screws to 16 N•m (12 ft-lb).
4. Repair the housing-side diaphragm.
 - a. Remove the 6 screws and the fluid cover from the housing side.
 - b. Remove the ball check seals.
 - c. The exposed diaphragm should be in the fully extended position (protruding out from the cylinder). If it is not, reassemble the cylinder-side seals and cover and repeat step 3.
 - d. Grip the housing-side diaphragm firmly and unscrew it from the rod by hand.
 - e. Install a new diaphragm (9*) firmly, by hand.
 - f. Install new ball check seals (29*).
 - g. Replace the fluid cover and install the 6 screws (39*). Torque the screws to 16 N•m (12 ft-lb).

Spare diaphragms should be stored in a cool, dry place and be used within 8 months to prevent diaphragm failure due to material aging.

 Torque to 16 N•m (12 ft-lb).

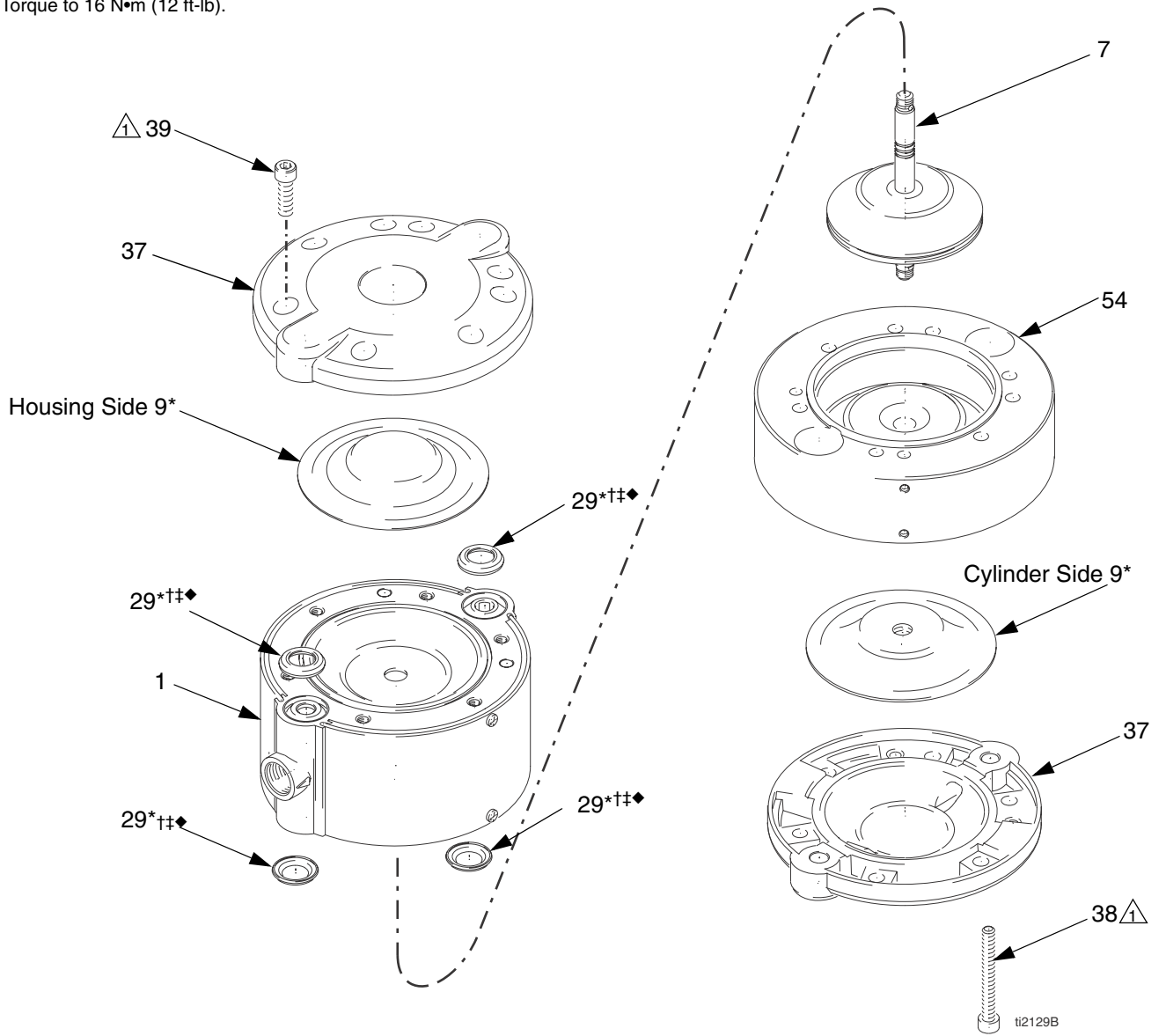



FIG. 4 Replace the Diaphragms

Repair the Air Valve

 Air Valve Repair Kit 245066 is available. Parts included in the kit are marked, for example (33†). For the best results, use all parts in the kit.

Disassembly

1. Prepare the pump for repair, page 13.
2. Remove the air valve sheet metal cover (36) and felt dampener (34).
3. Unscrew the cylinder screws (21).
4. Remove the valve cover (20) with the flat gasket (19†).
5. Use two screwdrivers to lift out the air valve plate (16†) and replace o-rings (17†◆) and (18†◆). Remove two o-rings (55).
6. Remove the air valve cup (15†).
7. Remove one retaining clip (14) with pliers DIN 5256C nominal size 12-25 diameter.
8. Screw cylinder screw (21) into the plug (12) and pull it out. Replace o-ring (13†◆).
9. Repeat steps 8 and 9 for clip and plug on opposite side.
10. Reach into the housing and press out the carriage (10).
11. Replace o-rings (11†◆).

Reassembly

 Lubricate all o-rings when reassembling the pump.

1. Assemble in reverse order.

 Orient the new flat gasket (19) on the air valve plate (16) so that the channels in the plate are completely covered.

 Note the orientation of the air valve plate (16) relative to the fluid outlet arrow, with "POM" marking up.

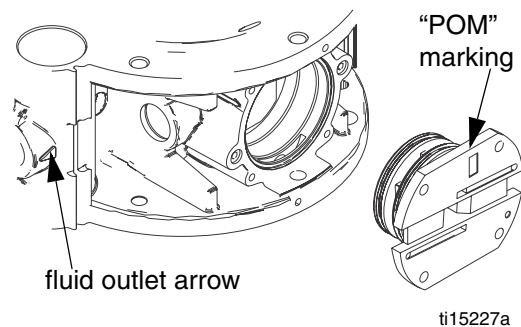

2. Replace all parts with the new ones supplied in kit 245066.

 Four profile seals (29) are provided in kit 245066 as in all 308HP kits. These seals need to be replaced only if the fluid covers are removed.

- ① Lubricate.
- ② Torque to 3.1 N•m (28 in-lb)

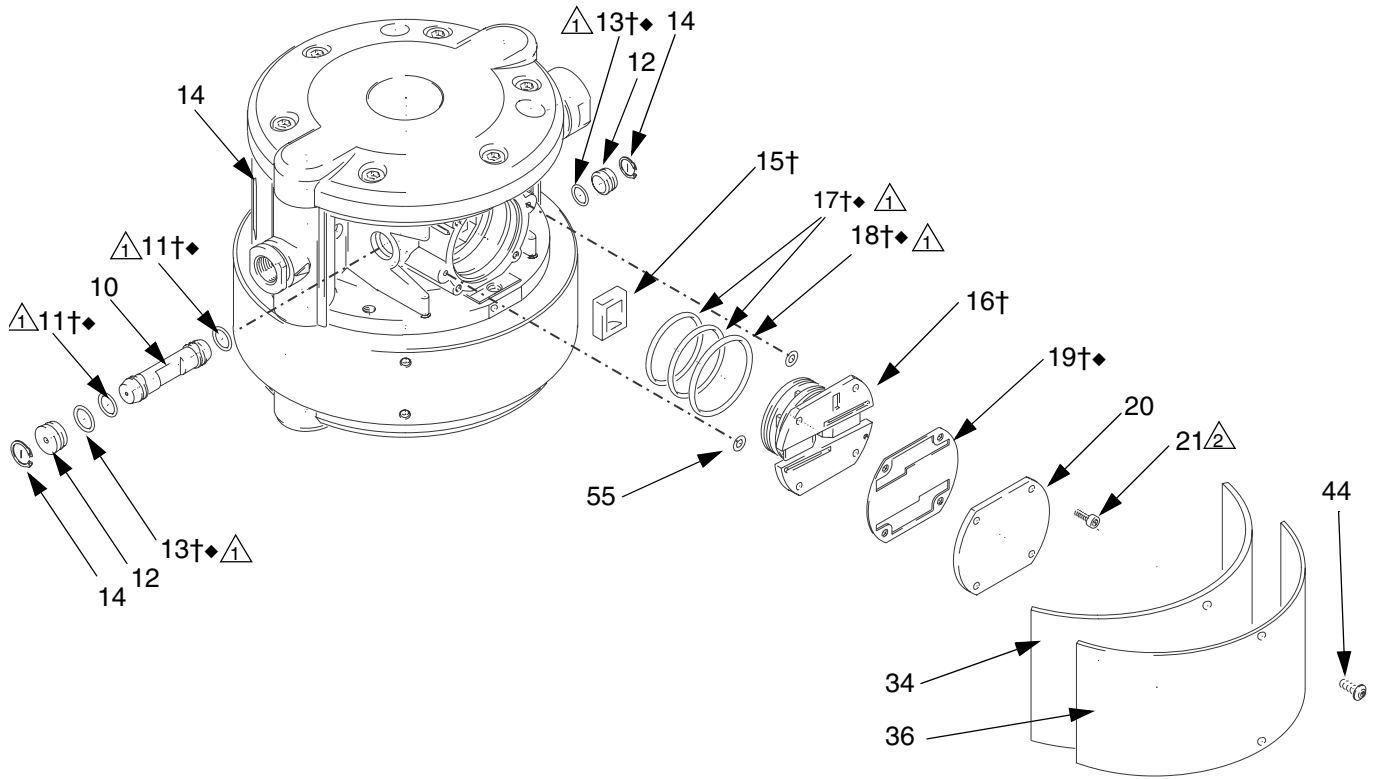

ti2130B

FIG. 5. Repair the Air Valve

Repair the Shaft and Bearings

 Parts marked with a (◆) are included in Shaft repair kit 233841. For the best results, use all parts in the repair kit.

Parts marked with a (❖) are included in Bearing repair kit 15J647.

Disassembly

1. Remove the diaphragms. See page 13.
2. Disassemble the air valve. See page 16.
3. Remove the housing (54).
 - Sleeve clamp (6) is visible inside the air valve cavity. Spread the sleeve clamp (6) with pliers DIN 5254A, nominal size 19, and at the same time, slide the shaft assembly (7) out from the end where housing (54) was removed.

 The valve carriage (5) will remain free inside the diaphragm housing.

4. Remove clip (42) and bearing (3).

Reassembly

1. Replace o-ring (2) in bearing, lubricate internal o-rings.
2. Install new bearing (3) and clip (42) inside housing (54).
3. Insert shaft assembly (7) into diaphragm housing (1) through the valve carriage, spreading the sleeve clamp to allow full insertion. Be careful to release sleeve clamp (6) in the correct location along the shaft to engage it in all three grooves.
4. Reinstall the housing (54).
5. Replace o-rings on the carriage, air valve plate, and plugs and reinstall the air valve section. (See page 16.)
6. Replace the diaphragms (page 13).
7. Replace the ball check seals (29) (page 20) and reinstall the fluid covers.

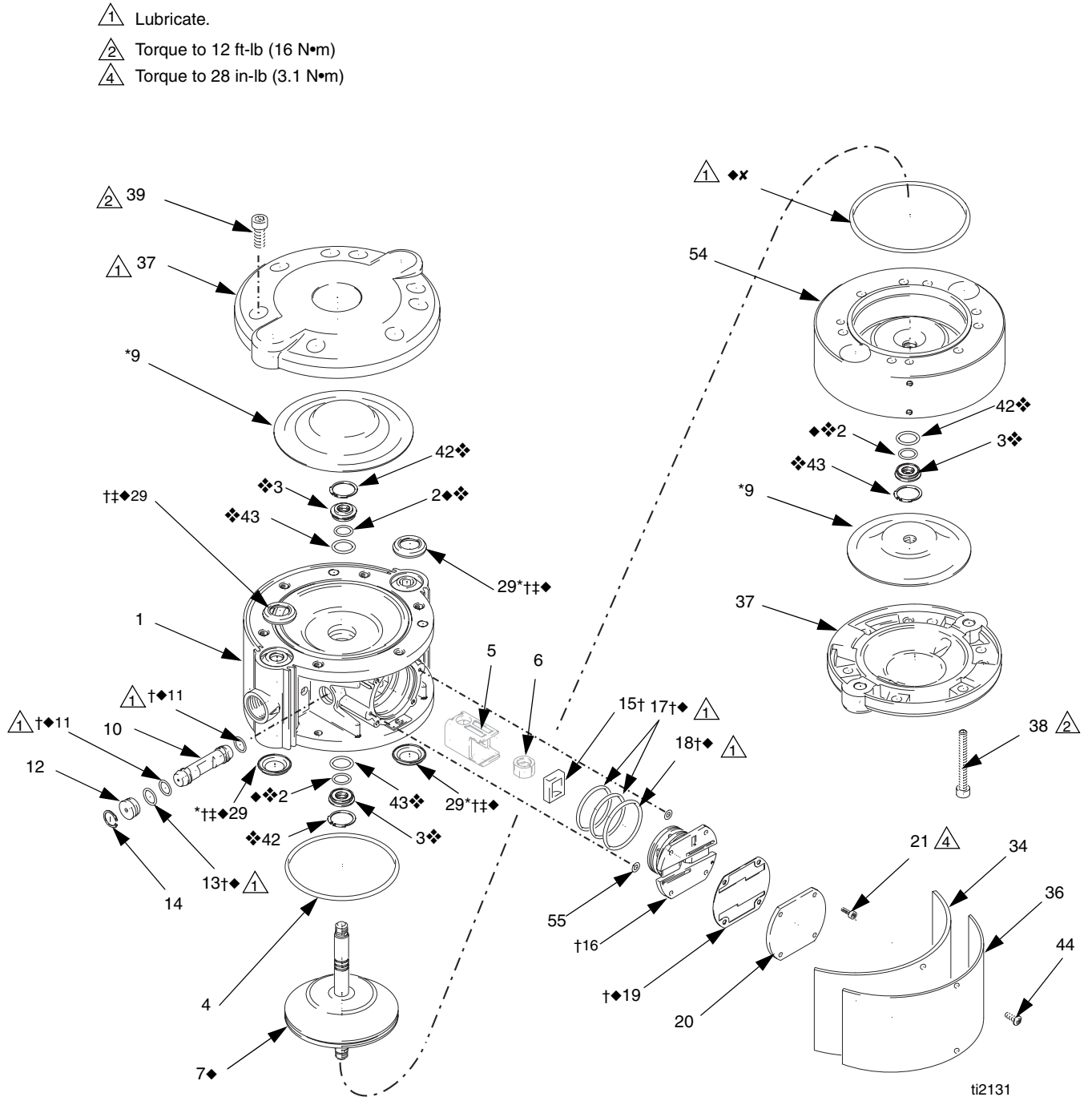

FIG. 6. Repair the Shaft

Replace the Ball Check Valves



Ball Check Valve Repair Kit 245067 is available. Parts included in the kit are marked with a (‡). For the best results, use all parts in the kit.

Disassembly

1. Remove fluid covers (see page 13). Do not remove housing (54).
2. Remove the inlet and outlet ball checks (26-32). Note that the orientation of the inlet check parts is different than the outlet check parts. (See FIG. 7.)



If the inlet seats (31) are difficult to remove, drive them out from the opposite side using a brass rod and hammer.

3. Replace all parts provided in Kit 245067.

Reassembly

1. Reinstall the inlet and outlet ball checks on one side of the pump. The inlet and outlet checks are assembled differently, install them exactly as shown in FIG. 7.
2. Install one fluid cover loosely to prevent the ball checks from falling out.



Align the through holes in the housing with each other and with the covers.

3. Turn the pump over and install the ball checks on the opposite side, exactly as shown.
4. Reinstall the fluid covers. (See page 13.)

 Torque to 12 ft-lb (16 N•m)

 Align

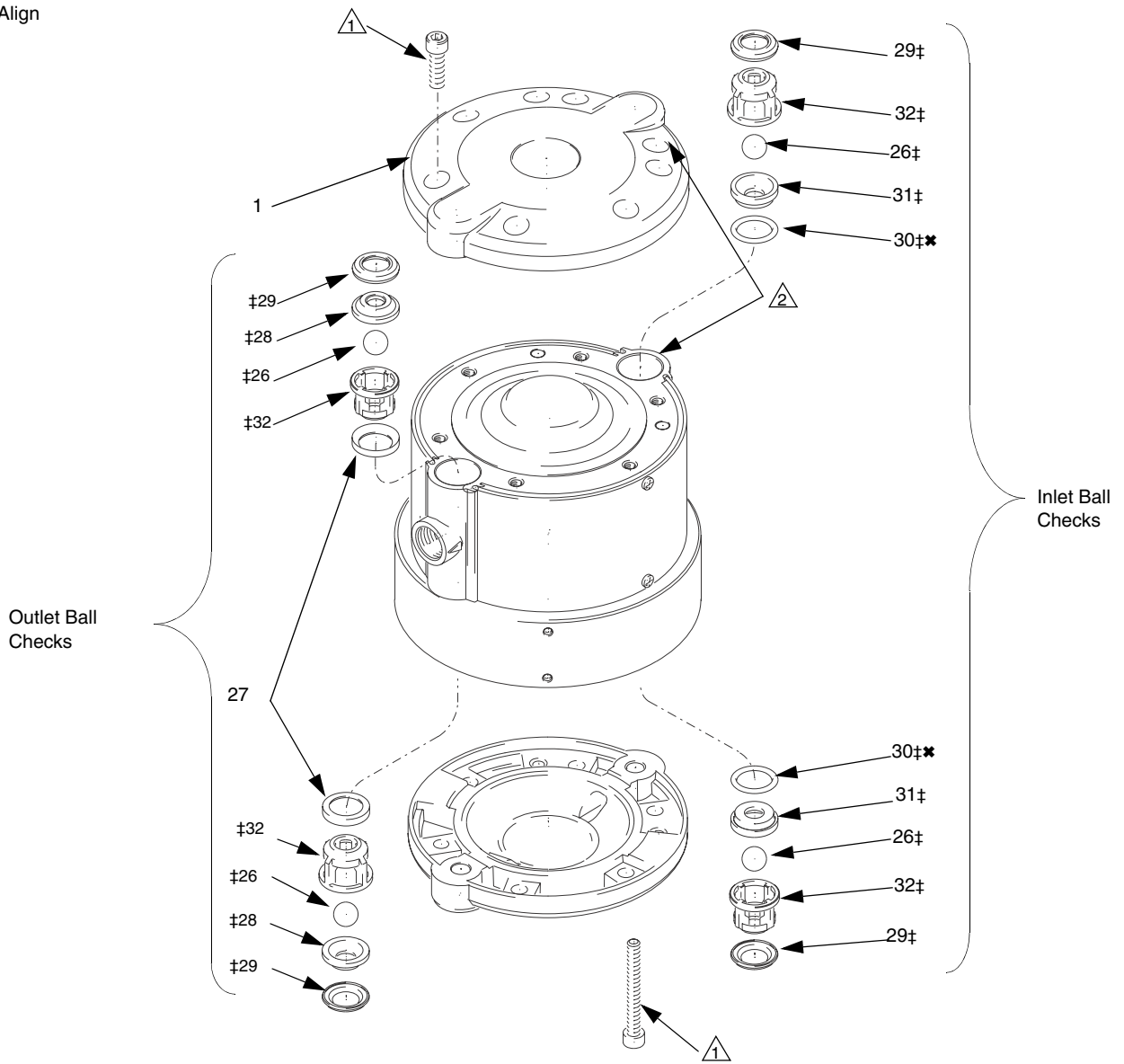

ti2128B

FIG. 7. Replace the Ball Check Valves

Parts

Part No. 253704, Series B

Part No. 253705, Series B

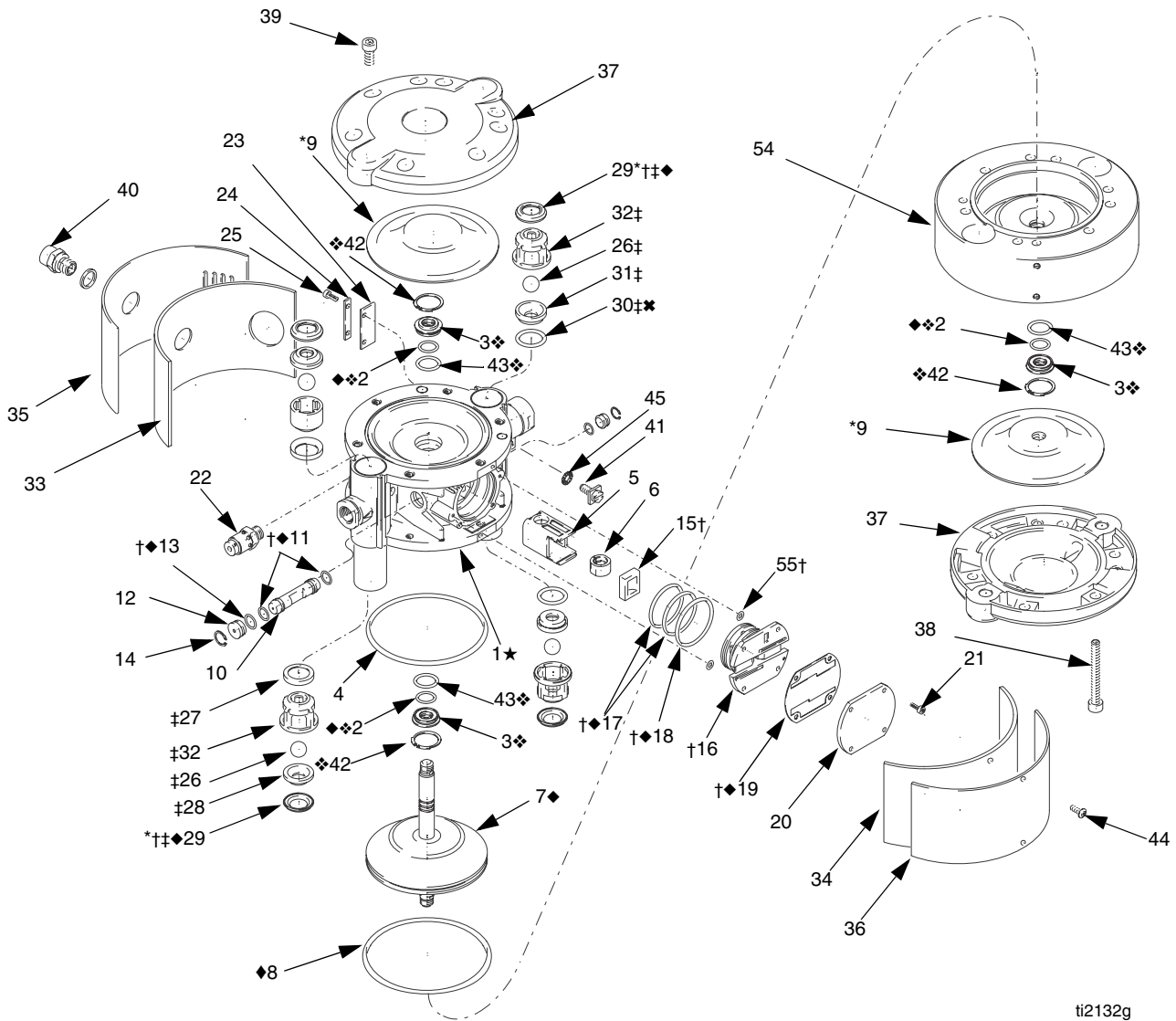

ti2132g

Part No. 253704 BSPP, Series B
Part No. 253705 NPT, Series B

Ref. No.	Part No.	Description	Qty	Ref. No.	Part No.	Description	Qty
1	★	HOUSING, diaphragm	1	40	15A286	ADAPTER, pump diaphragm, for 253704	1
2	◆❖	O-RING	3		198832	ADAPTER, pump diaphragm, for 253705	1
3	❖	BEARING	3	41	116343	CLAMP, grounding	1
4	117158	O-RING	1	42	❖	CLIP, ID, C-spring	3
5	197645	CARRIAGE, valve	1	43	❖	O-RING	3
6	15A289	CLAMP, sleeve	1	44	116595	SCREW, M4 button head	2
7	◆	SHAFT, pump, diaphragm	1	45	111307	WASHER (used with #41, 116343)	1
8	◆	O-RING	1	46▲	188621	LABEL, warning (not shown)	1
9	*	DIAPHRAGM	2	54	258001	HOUSING, cylinder	1
10	197649	CARRIAGE	1	55	†	O-RING	2
11	†◆	O-RING	2	★ Included in Diaphragm Housing Repair Kit. Order Kit 261665 for 253704 pumps and 261666 for 253705 pumps.			
12	197651	PLUG	2	◆ Included in Shaft Repair Kit 233841.			
13	†◆	O-RING	2	❖ Included in Bearing Repair Kit. Order Kit 15J647.			
14	197653	CLIP, id	2	* Included in Diaphragm Repair Kit 246011.			
15	†	CUP, air valve	1	† Included in Air Valve Repair Kit 245066.			
16	†	PLATE, air valve	1	‡ Included in Ball Check Valve Repair Kit 245067.			
17	†◆	O-RING	2	✖ Available in 10-pack kit 15D564.			
18	†◆	O-RING	1	▲ Replacement Warning labels, signs, tags, and cards are available at no cost.			
19	†◆	GASKET, flat	1				
20	197659	COVER, valve	1				
21	116474	SCREW, cap, socket head; M4x20 Torque to 3.1 N•m (2.3 ft-lb)	4				
22	117160	VALVE, safety	1				
23	197661	DAMPENER, noise	1				
24	197662	PLATE, screw	1				
25	116475	SCREW, cap, socket head; M4x12	2				
26	‡	BALL, matrix	4				
27	‡	SEAL, profile	2				
28	‡	SEAT, valve, outlet	2				
29	*†‡◆	SEAL, profile	4				
30	‡✖	O-RING	2				
31	‡	SEAT, valve, inlet	2				
32	‡	GUIDE, ball	4				
33	197670	DAMPENER, felt, side	1				
34	197671	DAMPENER, felt, air inlet side	1				
35	15J372	COVER, exhaust	1				
36	15J574	COVER, sheet metal, air valve	1				
37	15A282	COVER, fluid	2				
38	117240	SCREW, cap, socket head; M8x70 Torque to 12 N•m (8.8 ft-lb)	6				
39	115264	SCREW, cap, socket head; M8x16 Torque to 12 N•m (8.8 ft-lb)	6				

Technical Data

Category	Data
Maximum fluid working pressure	300 psi (2.1 MPa, 21 bar)
Maximum air input pressure	100 psi (0.7 MPa, 7 bar)
Ratio	3:1
Maximum permissible stroke frequency in cycles/min	20
Volume per cycle (double stroke)	5 oz/cycle (150 cc/cycle)
Operating temperature range	50-176°F (10-80°C)
Dry suction lift	5 ft (1.5 m)
Wet suction lift	21 ft (6.5 m)
Air inlet size	1/4 npt (253705); 3/8 BSPP (253704)
Fluid inlet size	3/4 npt (253705); M26x1.5 (253704)
Fluid outlet size	3/8 npt (253705); 3/8 BSPP (253704)
Weight (approximate)	28 lb (12.7 kg)
Wetted parts	stainless steel, acetal, fluorocarbon, PTFE, nylon

Sound Pressure Levels in dB(A) at 50 cpm (measured at 1 meter from unit)

Inlet Air Pressure	Sound Pressure
29 psi (0.2 MPa, 2.0 bar)	72
58 psi (0.4 MPa, 4.0 bar)	76
87 psi (0.6 MPa, 6.0 bar)	78
100 psi (0.7 MPa, 7.0 bar)	80

Performance Chart

Triton performance test, 40, 70, 100 psi (.27, .48, .69 MPa; 2.7, 4.8, 6.9 bar)

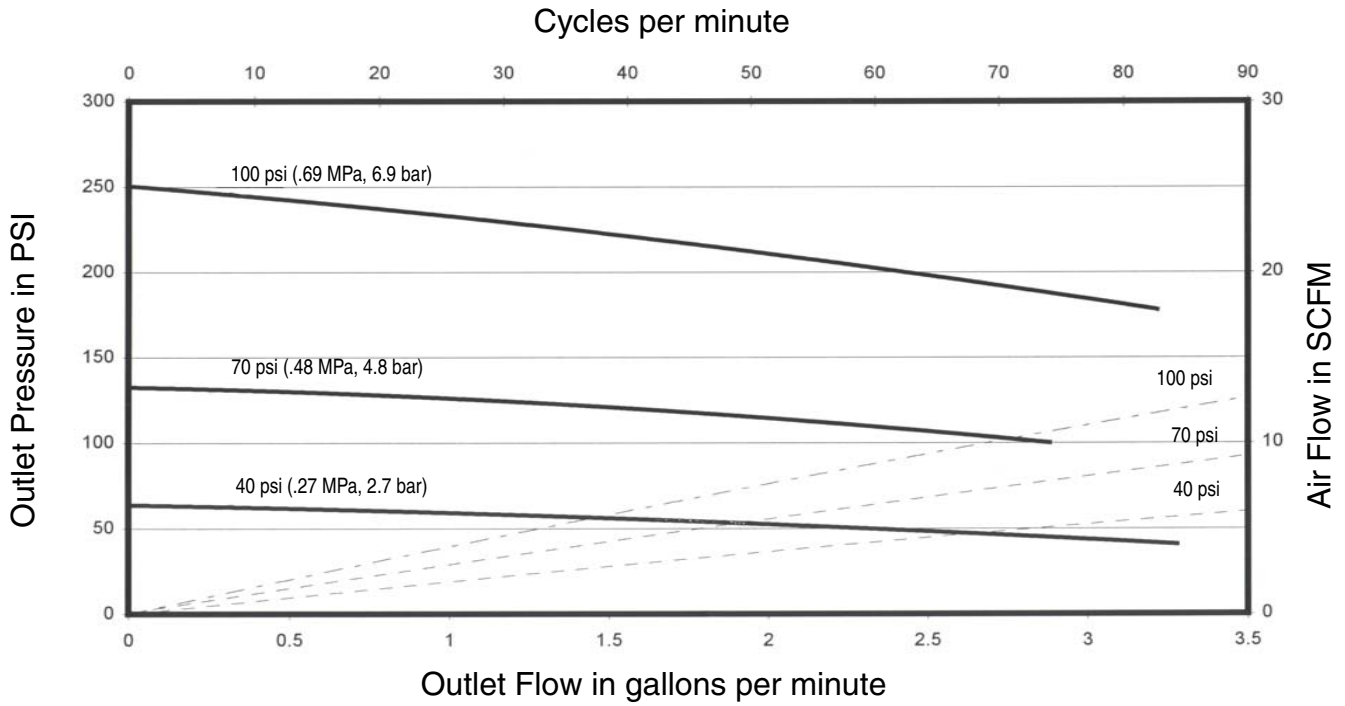

Dimensions

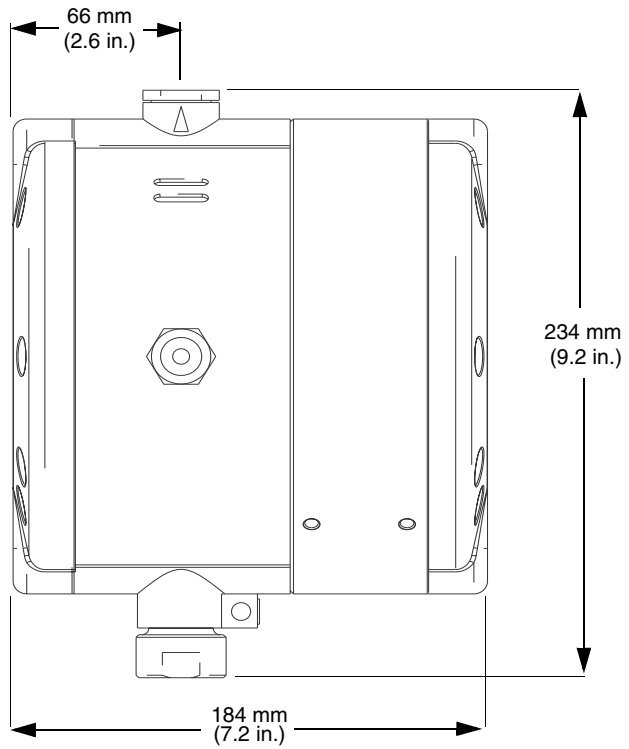

TI2133A 1

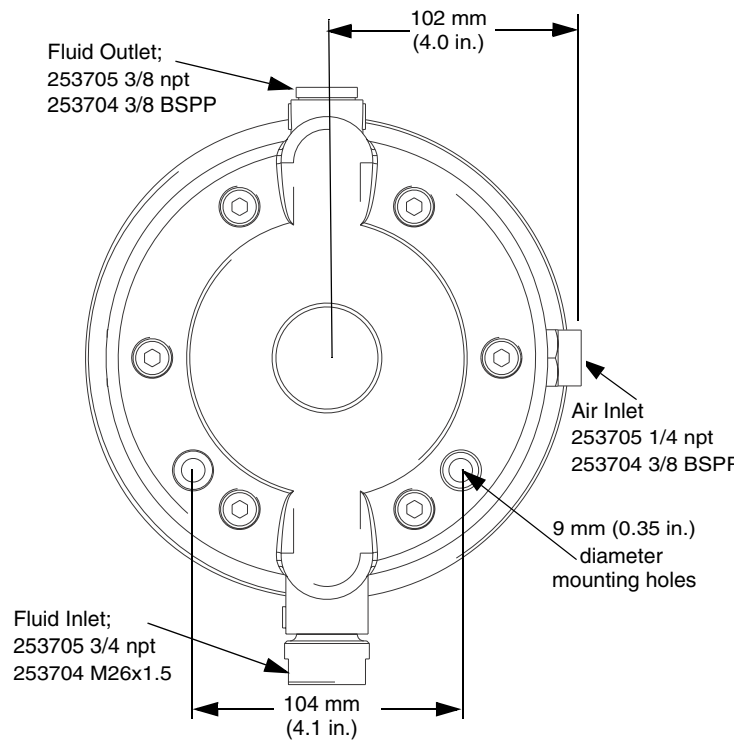

TI2133A 2



A series of horizontal lines for writing, consisting of 25 evenly spaced lines extending across the width of the page.

Graco Standard Warranty

Graco warrants all equipment referenced in this document which is manufactured by Graco and bearing its name to be free from defects in material and workmanship on the date of sale to the original purchaser for use. With the exception of any special, extended, or limited warranty published by Graco, Graco will, for a period of twelve months from the date of sale, repair or replace any part of the equipment determined by Graco to be defective. This warranty applies only when the equipment is installed, operated and maintained in accordance with Graco's written recommendations.

This warranty does not cover, and Graco shall not be liable for general wear and tear, or any malfunction, damage or wear caused by faulty installation, misapplication, abrasion, corrosion, inadequate or improper maintenance, negligence, accident, tampering, or substitution of non-Graco component parts. Nor shall Graco be liable for malfunction, damage or wear caused by the incompatibility of Graco equipment with structures, accessories, equipment or materials not supplied by Graco, or the improper design, manufacture, installation, operation or maintenance of structures, accessories, equipment or materials not supplied by Graco.

This warranty is conditioned upon the prepaid return of the equipment claimed to be defective to an authorized Graco distributor for verification of the claimed defect. If the claimed defect is verified, Graco will repair or replace free of charge any defective parts. The equipment will be returned to the original purchaser transportation prepaid. If inspection of the equipment does not disclose any defect in material or workmanship, repairs will be made at a reasonable charge, which charges may include the costs of parts, labor, and transportation.

THIS WARRANTY IS EXCLUSIVE, AND IS IN LIEU OF ANY OTHER WARRANTIES, EXPRESS OR IMPLIED, INCLUDING BUT NOT LIMITED TO WARRANTY OF MERCHANTABILITY OR WARRANTY OF FITNESS FOR A PARTICULAR PURPOSE.

Graco's sole obligation and buyer's sole remedy for any breach of warranty shall be as set forth above. The buyer agrees that no other remedy (including, but not limited to, incidental or consequential damages for lost profits, lost sales, injury to person or property, or any other incidental or consequential loss) shall be available. Any action for breach of warranty must be brought within two (2) years of the date of sale.

GRACO MAKES NO WARRANTY, AND DISCLAIMS ALL IMPLIED WARRANTIES OF MERCHANTABILITY AND FITNESS FOR A PARTICULAR PURPOSE, IN CONNECTION WITH ACCESSORIES, EQUIPMENT, MATERIALS OR COMPONENTS SOLD BUT NOT MANUFACTURED BY GRACO. These items sold, but not manufactured by Graco (such as electric motors, switches, hose, etc.), are subject to the warranty, if any, of their manufacturer. Graco will provide purchaser with reasonable assistance in making any claim for breach of these warranties.

In no event will Graco be liable for indirect, incidental, special or consequential damages resulting from Graco supplying equipment hereunder, or the furnishing, performance, or use of any products or other goods sold hereto, whether due to a breach of contract, breach of warranty, the negligence of Graco, or otherwise.

FOR GRACO CANADA CUSTOMERS

The Parties acknowledge that they have required that the present document, as well as all documents, notices and legal proceedings entered into, given or instituted pursuant hereto or relating directly or indirectly hereto, be drawn up in English. Les parties reconnaissent avoir convenu que la rédaction du présente document sera en Anglais, ainsi que tous documents, avis et procédures judiciaires exécutés, donnés ou intentés, à la suite de ou en rapport, directement ou indirectement, avec les procédures concernées.

Graco Information

For the latest information about Graco products, visit www.graco.com.

TO PLACE AN ORDER, contact your Graco distributor or call to identify the nearest distributor.

Phone: 612-623-6921 **or Toll Free:** 1-800-328-0211 **Fax:** 612-378-3505

*All written and visual data contained in this document reflects the latest product information available at the time of publication.
Graco reserves the right to make changes at any time without notice.*

Original instructions. This manual contains English. MM 311688

Graco Headquarters: Minneapolis

International Offices: Belgium, China, Japan, Korea

GRACO INC. P.O. BOX 1441 MINNEAPOLIS, MN 55440-1441

Copyright 2006, Graco Inc. is registered to ISO 9001

www.graco.com

Revised 02/2011