

# Instructions – Parts List



CARBON STEEL

## Check-Mate™ 2100 Pumps 308149P

With Priming Piston, and Severe-Duty Rod and Cylinder

**Part No. 222828 Pump, Series A**

**Part No. 246935 Pump, Series A**

**12:1 Ratio, with Bulldog® Air Motor**

*8.3 MPa, 83 bar (1200 psi) Maximum Fluid Working Pressure*

*0.7 MPa, 7 bar (100 psi) Maximum Air Input Pressure*

**Part No. 222829 Pump, Series A**

**12:1 Ratio, with Quiet Bulldog® Air Motor**

*8.3 MPa, 83 bar (1200 psi) Maximum Fluid Working Pressure*

*0.7 MPa, 7 bar (100 psi) Maximum Air Input Pressure*

**Part No. 222835 Pump, Series A**

**Part No. 246936 Pump, Series A**

**24:1 Ratio, with King™ Air Motor**

*16.6 MPa, 166 bar (2400 psi) Maximum Fluid Working Pressure*

*0.7 MPa, 7 bar (100 psi) Maximum Air Input Pressure*

**Part No. 222901 Pump, Series B**

**24:1 Ratio, with Quiet King™ Air Motor**

*16.6 MPa, 166 bar (2400 psi) Maximum Fluid Working Pressure*

*0.7 MPa, 7 bar (100 psi) Maximum Air Input Pressure*

**Part No. 222940 Pump, Series A**

**39:1 Ratio, with Premier™ Air Motor**

*26.9 MPa, 269 bar (3900 psi) Maximum Fluid Working Pressure*

*0.7 MPa, 7 bar (100 psi) Maximum Air Input Pressure*

**Part No. 222902 Pump, Series B**

**Part No. 246937 Pump, Series A**

**with Viscount® Hydraulic Motor**

*15.9 MPa, 159 bar (2300 psi) Maximum Fluid Working Pressure*

*10 MPa, 103 bar (1500 psi) Maximum Hydraulic Input Pressure*

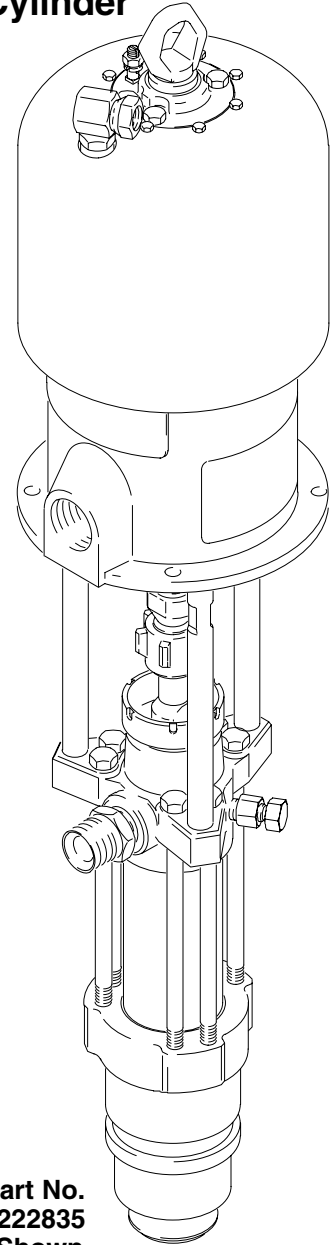

**Part No.  
222835  
Shown**



### Important Safety Instructions

Read all warnings and instructions in this manual.  
Save these instructions.

See page 2 for **Table of Contents**.

PROVEN QUALITY. LEADING TECHNOLOGY.

# Table of Contents

Warnings .....	3	Disconnecting the Displacement Pump .....	16
Installation .....	7	Reconnecting the Displacement Pump .....	18
Installation (Air-Powered Pumps) .....	8	Displacement Pump Service .....	19
Installation (Hydraulic-Powered Pumps) .....	10	Parts Drawings and Lists	
Operation/Maintenance		Pump Assemblies .....	25
All Models .....	12	Displacement Pump .....	28
Air-Powered Models .....	12	Technical Data and Performance Charts .....	30
Hydraulic-Powered Models .....	14	Dimensions .....	36
Service		Mounting Hole Layout .....	37
Troubleshooting Chart .....	15	Graco Standard Warranty .....	38
Required Tools .....	16	Graco Information .....	38

# Symbols

## Warning Symbol



This symbol alerts you to the possibility of serious injury or death if you do not follow the instructions.

## Caution Symbol



This symbol alerts you to the possibility of damage to or destruction of equipment if you do not follow the instructions.

## WARNING



INSTRUCTIONS

### EQUIPMENT MISUSE HAZARD

Equipment misuse can cause the equipment to rupture or malfunction and result in serious injury.

- This equipment is for professional use only.
- Read all instruction manuals, tags, and labels before operating the equipment.
- Use the equipment only for its intended purpose. If you are uncertain about usage, call your Graco distributor.
- Do not alter or modify this equipment. Use only genuine Graco parts and accessories.
- Check equipment daily. Repair or replace worn or damaged parts immediately.
- Do not exceed the maximum working pressure of the lowest rated system component. Refer to the **Technical Data** on pages 30–35 for the maximum working pressure of this equipment.
- Use fluids and solvents which are compatible with the equipment wetted parts. Refer to the **Technical Data** section of all equipment manuals. Read the fluid and solvent manufacturer's warnings.
- Do not kink or overbend hoses or use hoses to pull equipment.
- Route hoses away from traffic areas, sharp edges, moving parts, and hot surfaces. Do not expose Graco hoses to temperatures above 82°C (180°F) or below –40°C (–40°F).
- Wear hearing protection when operating this equipment.
- Do not lift pressurized equipment.
- Comply with all applicable local, state, and national fire, electrical, and safety regulations.

# WARNING



## SKIN INJECTION HAZARD

Spray from the gun/valve, hose leaks, or ruptured components can inject fluid into your body and cause extremely serious injury, including the need for amputation. Fluid splashed in the eyes or on the skin can also cause serious injury.



- Fluid injected into the skin might look like just a cut, but it is a serious injury. **Get immediate surgical treatment.**
- Do not point the gun/valve at anyone or at any part of the body.
- Do not put your hand or fingers over the spray tip/nozzle.
- Do not stop or deflect leaks with your hand, body, glove or rag.
- Do not “blow back” fluid; this is not an air spray system.
- Always have the tip guard and the trigger guard on the gun/valve when spraying.
- Be sure the gun/valve trigger safety operates before spraying.
- Lock the gun/valve trigger safety when you stop spraying.
- Follow the **Pressure Relief Procedure** on page 12 whenever you: are instructed to relieve pressure; stop spraying; clean, check, or service the equipment; and install or clean the spray tip/nozzle.
- Tighten all fluid connections before operating the equipment.
- Check the hoses, tubes, and couplings daily. Replace worn, damaged, or loose parts immediately. Permanently coupled hoses cannot be repaired; replace the entire hose.
- Use only Graco approved hoses. Do not remove any spring guard that is used to help protect the hose from rupture caused by kinks or bends near the couplings.



## MOVING PARTS HAZARD

Moving parts, such as the air motor piston, can pinch or amputate your fingers.

- Keep clear of all moving parts when starting or operating the pump.
- Before servicing the equipment, follow the **Pressure Relief Procedure** on page 12 to prevent the equipment from starting unexpectedly.

# WARNING



## FIRE AND EXPLOSION HAZARD

Improper grounding, poor ventilation, open flames or sparks can cause a hazardous condition and result in a fire or explosion and serious injury.

- Ground the equipment and the object being sprayed. Refer to **Grounding** on page 7.
- If there is any static sparking or you feel an electric shock while using this equipment, **stop spraying immediately**. Do not use the equipment until you identify and correct the problem.
- Provide fresh air ventilation to avoid the buildup of flammable fumes from solvents or the fluid being sprayed.
- Keep the spray area free of debris, including solvent, rags, and gasoline.
- Electrically disconnect all equipment in the spray area.
- Extinguish all open flames or pilot lights in the spray area.
- Do not smoke in the spray area.
- Do not turn on or off any light switch in the spray area while operating or if fumes are present.
- Do not operate a gasoline engine in the spray area.
- Keep a fire extinguisher in the work area.



## TOXIC FLUID HAZARD

Hazardous fluid or toxic fumes can cause serious injury or death if splashed in the eyes or on the skin, inhaled, or swallowed.

- Know the specific hazards of the fluid you are using.
- Store hazardous fluid in an approved container. Dispose of hazardous fluid according to all local, state and national guidelines.
- Always wear protective eyewear, gloves, clothing and respirator as recommended by the fluid and solvent manufacturer.



# Installation

## Grounding

### WARNING



#### FIRE AND EXPLOSION HAZARD

Before operating the pump, ground the system as explained below. Also read the section **FIRE AND EXPLOSION HAZARD** on page 5.

1. *King Pumps:* use a ground wire and clamp. See Fig. 1. Remove the ground screw (Z) and insert through eye of ring terminal at the end of ground wire (Y). Fasten ground screw back onto pump and tighten securely. Connect the other end of the wire to a true earth ground. Order Part No. 222011 Ground Wire and Clamp.

*All Other Pumps:* use a ground wire and clamp. See Fig. 2. Loosen the grounding lug locknut (W) and washer (X). Insert one end of a 1.5 mm<sup>2</sup> (12 ga) minimum ground wire (Y) into the slot in lug (Z) and tighten the locknut securely. Connect the other end of the wire to a true earth ground. Order Part No. 237569 Ground Wire and Clamp.

2. *Air and hydraulic hoses:* use only electrically conductive hoses.
3. *Fluid hoses:* use only electrically conductive fluid hoses.
4. *Air compressor or hydraulic power supply:* follow manufacturer's recommendations.
5. *Spray gun/dispensing valve:* grounding is obtained through connection to a properly grounded fluid hose and pump.
6. *Fluid supply container:* according to your local code.

7. *Object being sprayed:* according to your local code.
8. *All solvent pails used when flushing,* according to your local code. Use only metal pails, which are conductive, placed on a grounded surface. Do not place the pail on a nonconductive surface, such as paper or cardboard, which interrupts the grounding continuity.
9. *To maintain grounding continuity when flushing or relieving pressure,* always hold a metal part of the spray gun/dispensing valve firmly to the side of a grounded metal pail, then trigger the gun/valve.

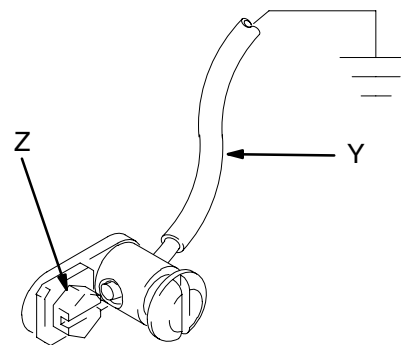

Fig. 1

T11052

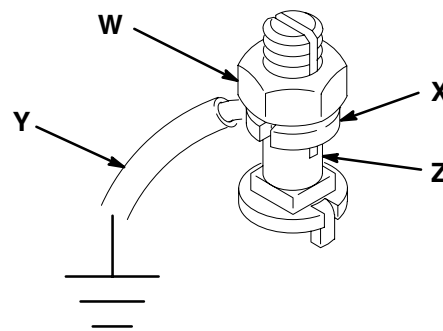

Fig. 2

0864

# Installation

## (AIR-POWERED PUMPS)

**NOTE:** Reference numbers and letters in parentheses in the text refer to the callouts in the figures and the parts drawings.

Accessories are available from your Graco distributor. If you supply your own accessories, be sure they are adequately sized and pressure-rated to meet the system's requirements.

The Typical Installation shown in Fig. 3 is only a guide for selecting and installing system components and accessories. Contact your Graco distributor for assistance in designing a system to suit your particular needs.

### KEY

- |   |   |
|---|---|
| <b>A</b> Pump   | <b>K</b> Bleed-Type Master Air Valve (for accessories)                    |
| <b>B</b> 200 Liter (55 Gallon) Air-Powered Ram            | <b>L</b> Fluid Regulator  |
| <b>C</b> Pump Runaway Valve                               | <b>M</b> Fluid Drain Valve (required)                                     |
| <b>D</b> Air Line Lubricator                              | <b>N</b> Electrically Conductive Fluid Supply Hose                        |
| <b>E</b> Bleed-Type Master Air Valve (required, for pump) | <b>P</b> Fluid Shutoff Valve  |
| <b>F</b> Pump Air Regulator                               | <b>R</b> Gun/Valve Swivel   |
| <b>G</b> Air Manifold                                     | <b>S</b> Airless Spray Gun or Dispensing Valve                            |
| <b>H</b> Electrically Conductive Air Supply Hose          | <b>T</b> Ram Air Regulator  |
| <b>J</b> Air Line Filter                                  | <b>Y</b> Ground Wire (required, see page 7 for installation instructions) |

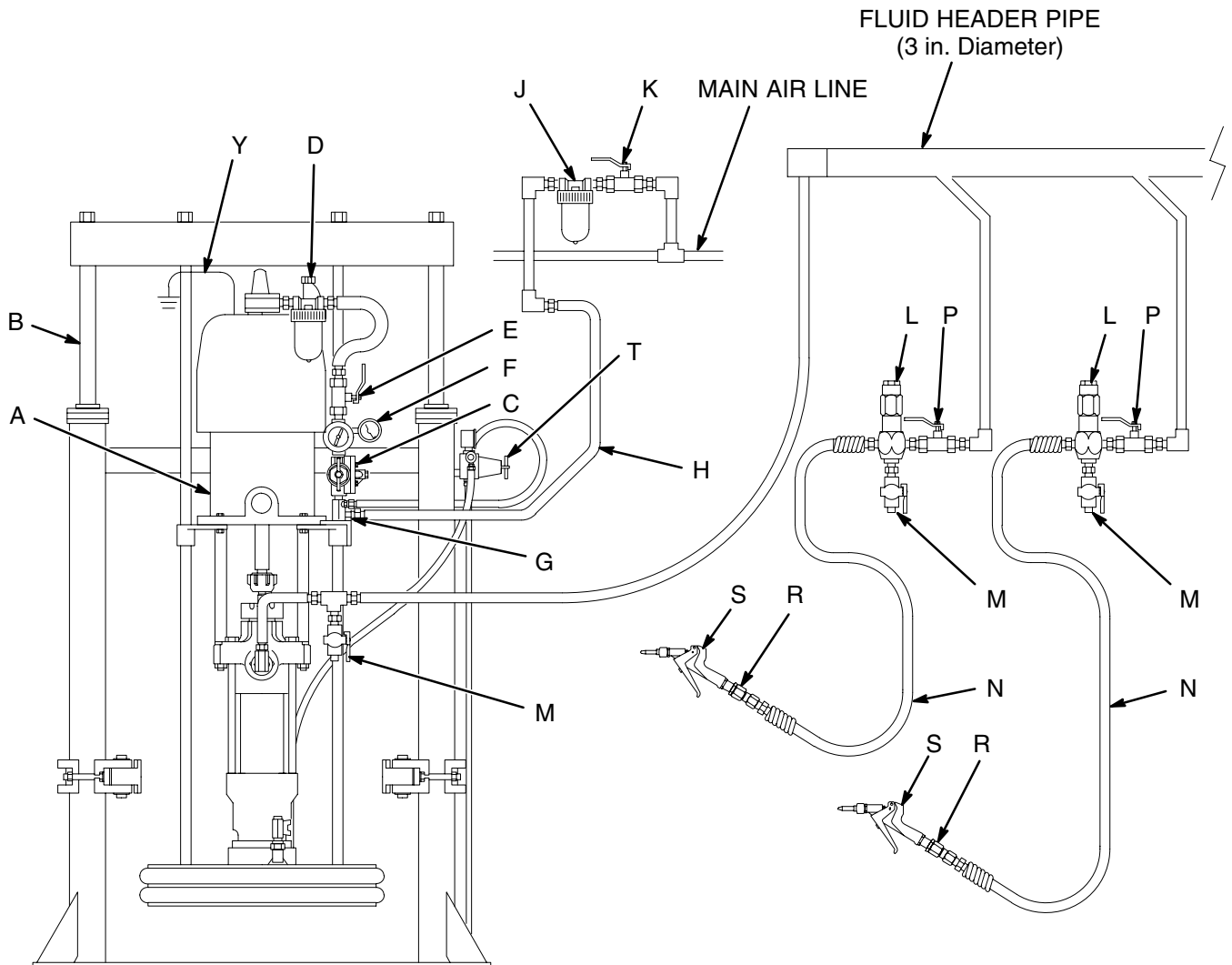

01177A

Fig. 3



# Installation

## (AIR-POWERED PUMPS)

### SYSTEM ACCESSORIES

#### WARNING

A bleed-type master air valve (E) and a fluid drain valve (M) are required in your system. These accessories help reduce the risk of serious injury, including fluid injection and splashing of fluid in the eyes or on the skin, and injury from moving parts if you are adjusting or repairing the pump.

The bleed-type master air valve relieves air trapped between this valve and the pump after the air is shut off. Trapped air can cause the pump to cycle unexpectedly. Locate the valve close to the pump.

The fluid drain valve assists in relieving fluid pressure in the displacement pump, hose, and gun. Triggering the gun to relieve pressure may not be sufficient.

### Air and Fluid Hoses

Be sure all air hoses (H) and fluid hoses (N) are properly sized and pressure-rated for your system. Use only electrically conductive hoses. Fluid hoses must have spring guards on both ends.

### Mounting Accessories

#### WARNING

For Model 222940 Premier Pump, do not lift the pump by the lift ring when the total weight exceeds 550 lb (250 kg).

Mount the pump (A) to suit the type of installation planned. Fig. 3 on page 8 illustrates a ram-mounted pump in a multi-gun header system. Pump dimensions and the mounting hole layout are shown on pages 36 and 37.

If you are mounting the pump on a ram, refer to the separate ram manual for installation and operation instructions.

### Air Line Accessories

Install the following accessories in the order shown in Fig. 3, using adapters as necessary:

- **An air line lubricator (D)** provides automatic air motor lubrication.

- **A bleed-type master air valve (E)** is required in your system to relieve air trapped between it and the air motor when the valve is closed (see the **WARNING** above). Be sure the bleed valve is easily accessible from the pump, and is located **downstream** from the air regulator.
- **An air regulator (F)** controls pump speed and outlet pressure by adjusting the air pressure to the pump. Locate the regulator close to the pump, but **upstream** from the bleed-type master air valve.
- **A pump runaway valve (C)** senses when the pump is running too fast and automatically shuts off the air to the motor. A pump which runs too fast can be seriously damaged.
- **An air manifold (G)** has a swivel air inlet. It mounts to a ram, and has ports for connecting lines to air accessories, such as the **ram air regulator (T)**.
- **An air line filter (J)** removes harmful dirt and moisture from the compressed air supply.
- **A second bleed-type air valve (K)** isolates the air line accessories for servicing. Locate upstream from all other air line accessories.

### Fluid Line Accessories

Install the following accessories in the positions shown in Fig. 3, using adapters as necessary:

- Install a **fluid shutoff valve (P)** at each gun drop, to isolate the gun and fluid accessories for servicing.
- Install a **fluid drain valve (M)** near the pump fluid outlet, and at each gun station. The drain valves are required in your system to relieve fluid pressure in the displacement pump, hose and gun (see the **WARNING** at left). Drain valves at the gun stations may be mounted in the base of a **fluid regulator (L)**, using an adapter.
- **A fluid regulator (L)** controls fluid pressure to the gun/valve, and dampens pressure surges.
- **A gun or valve (S)** dispenses the fluid. The gun shown in Fig. 3 is a high pressure dispensing gun for highly viscous fluids.
- **A gun swivel (R)** allows freer gun movement.

# Installation

## (HYDRAULIC-POWERED PUMPS)

**NOTE:** Reference numbers and letters in parentheses in the text refer to the callouts in the figures and the parts drawing.

Accessories are available from your Graco . If you supply your own accessories, be sure they are adequately sized and pressure-rated to meet the system's requirements.

The Typical Installation shown in Fig. 4 is only a guide for selecting and installing system components and accessories. Contact your Graco distributor for assistance in designing a system to suit your particular needs.

### ⚠ CAUTION

It is very important to keep the hydraulic supply system clean at all times. Be sure that all hydraulic fluid lines are absolutely clean. Blow out the lines with air and flush thoroughly with solvent before connecting to the hydraulic motor, to avoid introducing harmful contaminants into the motor. Plug the hydraulic lines immediately when they are disconnected.

Do not exceed 37.8 liter/min (10 gpm) hydraulic oil volume to the motor, to avoid pump stalling.

For optimum pump performance, keep the temperature of the hydraulic oil below 54° C (130° F)

#### KEY

- |  |   |
|--|---|
| <b>A</b> Pump                                      | <b>U</b> Hydraulic Supply Line Shutoff Valve                              |
| <b>B</b> 200 Liter (55 Gallon) Air-Powered Ram     | <b>V</b> Hydraulic Return Line Shutoff Valve                              |
| <b>C</b> Hydraulic Supply Line                     | <b>Y</b> Ground Wire (required, see page 7 for installation instructions) |
| <b>D</b> Hydraulic Return Line                     | <b>AA</b> Hydraulic Return Line Filter                                    |
| <b>E</b> Drain Line (from pressure reducing valve) |   |
| <b>F</b> Pressure Gauge                            |   |
| <b>G</b> Flow Control Valve                        |   |
| <b>H</b> Pressure Reducing Valve                   |   |
| <b>J</b> Accumulator                               |   |
| <b>K</b> Drain Line (from motor drip pan)          |   |
| <b>L</b> Fluid Regulator                           |   |
| <b>M</b> Fluid Drain Valve (required)              |   |
| <b>N</b> Electrically Conductive Fluid Supply Hose |   |
| <b>P</b> Fluid Shutoff Valve                       |   |
| <b>R</b> Gun/Valve Swivel                          |   |
| <b>S</b> Airless Spray Gun or Dispensing Valve     |   |
| <b>T</b> Ram Air Regulator                         |   |

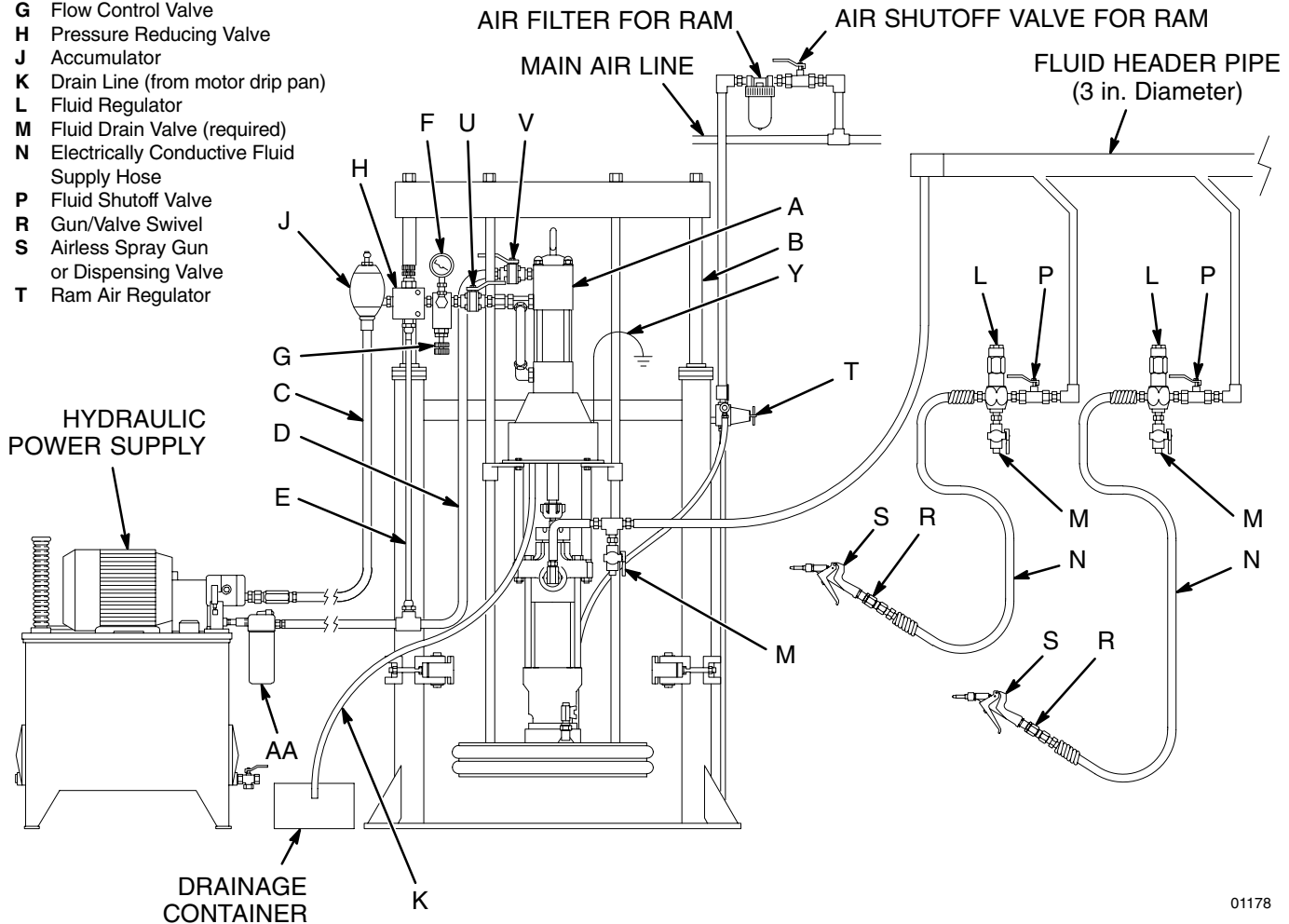

Fig. 4

01178

# Installation

## (HYDRAULIC-POWERED PUMPS)

### SYSTEM ACCESSORIES

#### WARNING

A fluid drain valve (M) is required in your system to help reduce the risk of serious injury, including fluid injection and splashing of fluid in the eyes or on the skin if you are adjusting or repairing the pump.

The fluid drain valve assists in relieving fluid pressure in the displacement pump, hose, and gun. Triggering the gun to relieve pressure may not be sufficient.

### Mounting Accessories

Mount the pump (A) to suit the type of installation planned. Fig. 4 on page 10 illustrates a ram-mounted pump in a multi-gun header system. Pump dimensions and the mounting hole layout are shown on pages 36 and 37.

If you are mounting the pump on a air-powered ram, refer to the separate ram manual for installation and operation instructions, and recommended air accessories.

### Filters

Be sure your hydraulic power supply is equipped with a suction filter to the hydraulic pump and a system return line filter (AA) of 10 micron size.

Carefully follow the manufacturer's recommendations on reservoir and filter cleaning, and periodic changes of hydraulic fluid. Use only Graco-approved hydraulic oil. Order Part No. 169236, 5 gal. (19 liter) or 207428, 1 gal. (3.8 liter). Do not substitute a lower grade oil or one with a lower flash point.

### Hydraulic Lines

The motor has a 3/4 npt(f) hydraulic oil supply fitting, and a 1" npt(f) hydraulic oil return fitting. Use a minimum 13 mm (1/2 in.) ID hydraulic supply line, and a minimum 16 mm (5/8 in.) ID return line.

**On the hydraulic supply line (C),** install the following accessories in the order shown in Fig. 4, using adapters as necessary:

- **A shutoff valve (U)** to isolate the pump for servicing.
- **A fluid pressure gauge (F)** to monitor hydraulic oil pressure to the motor and to avoid overpressurizing the motor or displacement pump, and **a pressure- and temperature-compensated flow control valve (G)** to prevent the motor from running too fast and possibly damaging itself.
- **A pressure reducing valve (H), with a drain line (E)** running into the hydraulic return line (D).
- **An accumulator (J)** to reduce the hammering effect caused by the motor reversing direction.

**On the hydraulic return line (D),** install the following accessories in the order shown in Fig. 4, using adapters as necessary:

- **A shutoff valve (V)** to isolate the pump for servicing.
- **A filter (AA)** of 10 micron size.

### Hydraulic Motor Drip Pan

The hydraulic motor has a drip pan to collect any leakage that may occur. Connect a 6 mm (1/4 in.) ID drain line (K) to the barbed hose fitting on the drip pan, and place the free end in a suitable container to receive the drainage.

### Fluid Supply Hoses

Be sure the fluid supply hose (N) is properly sized and pressure-rated for your system. Use only electrically conductive hoses. Fluid hoses must have spring guards on both ends.

### Fluid Line Accessories

Install the following accessories in the positions shown in Fig. 4, using adapters as necessary:

- Install a **fluid shutoff valve (P)** at each gun drop, to isolate the gun and fluid accessories for servicing.
- Install a **fluid drain valve (M)** near the pump fluid outlet, and at each gun station. The drain valves are required in your system to relieve fluid pressure in the displacement pump, hose and gun (see the **WARNING** at left). Drain valves at the gun stations may be mounted in the base of a **fluid regulator (L)**, using an adapter.
- **A fluid regulator (L)** controls fluid pressure to the gun/valve, and dampens pressure surges.
- **A gun or valve (S)** dispenses the fluid. The gun shown in Fig. 4 is a high pressure dispensing gun for highly viscous fluids.
- **A gun swivel (R)** allows freer gun movement.

# Operation

(ALL MODELS)

## Pressure Relief Procedure

### WARNING

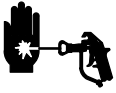

#### SKIN INJECTION HAZARD

Fluid under high pressure can be injected through the skin and cause serious injury. To reduce the risk of an injury from injection, splashing fluid, or moving parts, follow the **Pressure Relief Procedure** whenever you:

- are instructed to relieve the pressure,
- stop spraying/dispensing,
- check or service any of the system equipment,
- or install or clean the spray tip/nozzle.

1. Engage the gun/valve trigger safety.
2. Shut off the air or hydraulic supply to the pump.
3. In air-powered systems, close the bleed-type master air valve (required in your system). In hydraulic-powered systems, close the hydraulic supply line valve first, then the return line valve.
4. Unlock the gun/valve safety latch.
5. Hold a metal part of the gun/valve firmly to the side of a grounded metal pail, and trigger the gun/valve to relieve pressure.
6. Lock the gun/valve safety latch.
7. Open the drain valve (required in your system) and/or the pump bleeder valve, having a container ready to catch the drainage.
8. Leave the drain valve open until you are ready to spray/dispense again.

If you suspect that the spray tip/nozzle or hose is completely clogged, or that pressure has not been fully relieved after following the steps above, very slowly loosen the tip guard retaining nut, nozzle, or hose end coupling and relieve pressure gradually, then loosen completely. Now clear the tip/nozzle or hose.

## Packing Nut/Wet-Cup

Fill the packing nut/wet-cup (2) 1/3 full with Graco Throat Seal Liquid (TSL) or compatible solvent. See Fig. 5. Using the supplied wrench (104), adjust the packing nut weekly so it is just snug; do not overtighten. Follow the **Pressure Relief Procedure** above before adjusting the packing nut.

## Flushing the Pump

The pump is tested with lightweight oil, which is left in to protect the pump parts. If the fluid you are using may be contaminated by the oil, flush it out with a compatible solvent before using the pump.

### WARNING

Before operating the pump, ground the system as explained under **FIRE AND EXPLOSION HAZARD** and **Grounding** on page 5.

(AIR-POWERED MODELS)

## Starting and Adjusting the Pump

Supply fluid to the pump, per the requirements of your system.

Refer to Fig. 3 on page 8. Be sure the air regulator (F) is closed. Then open the pump's bleed-type master air valve (E). Hold a metal part of the spray gun/dispensing valve (S) firmly to the side of a grounded metal pail and hold the trigger open. Now slowly open the air regulator until the pump starts.

Cycle the pump slowly until all the air is pushed out and the pump and hoses are fully primed. Release the spray gun/dispensing valve trigger and engage the safety latch. The pump should stall against pressure when the trigger is released.

If the pump fails to prime properly, open the bleeder valve plug (35) slightly. Use the bleed hole, on the underside of the valve body (34), as a priming valve until the fluid appears at the hole. See Fig. 5. Close the plug (35).

**NOTE:** When changing fluid containers with the hose and gun already primed, open the bleeder valve plug (35), to assist in priming the pump and venting air before it enters the hose. Close the bleeder valve when all air has been eliminated.

### WARNING

To reduce the risk of fluid injection, do not use your hand or fingers to cover the bleed hole when priming the pump.

# Operation

## (AIR-POWERED MODELS)

With the pump and lines primed, and with adequate air pressure and volume supplied, the pump will start and stop as the gun/valve is opened and closed. In a circulating system, the pump will speed up or slow down on demand, until the air supply is shut off.

Use the air regulator (F) to control the pump speed and the fluid pressure. Always use the lowest air pressure necessary to get the desired results. Higher pressures cause premature tip/nozzle and pump wear.

### **WARNING**

To reduce the risk of overpressurizing your system, which could result in component rupture and cause serious injury, never exceed the specified maximum incoming air pressure to the pump (see the **Technical Data** on pages 30–35)

Never allow the pump to run dry of the fluid being pumped. A dry pump will quickly accelerate to a high speed, possibly damaging itself. A pump runaway valve (C), which shuts off the air supply to the pump if the pump accelerates beyond the pre-set speed, is available. See Fig. 3 on page 8. If your pump accelerates quickly, or is running too fast, stop it immediately and check the fluid supply. If the supply container is empty and air has been pumped into the lines, refill the container and prime the pump and the lines with fluid, or flush and leave it filled with a compatible solvent. Be sure to eliminate all air from the fluid system.

### Shutdown and Care of the Pump

### **WARNING**

To reduce the risk of serious injury whenever you are instructed to relieve pressure, always follow the **Pressure Relief Procedure** on page 12.

For overnight shutdown, **relieve the pressure**. Stop the pump at the bottom of the stroke to prevent fluid from drying on the exposed displacement rod and damaging the throat packings.

Always flush the pump before the fluid dries on the displacement rod. Never leave water or water-based fluid in the pump overnight. First, flush with water or a compatible solvent, then with mineral spirits. Relieve the pressure, but leave the mineral spirits in the pump to protect the parts from corrosion.

### **Model 222835 Shown**

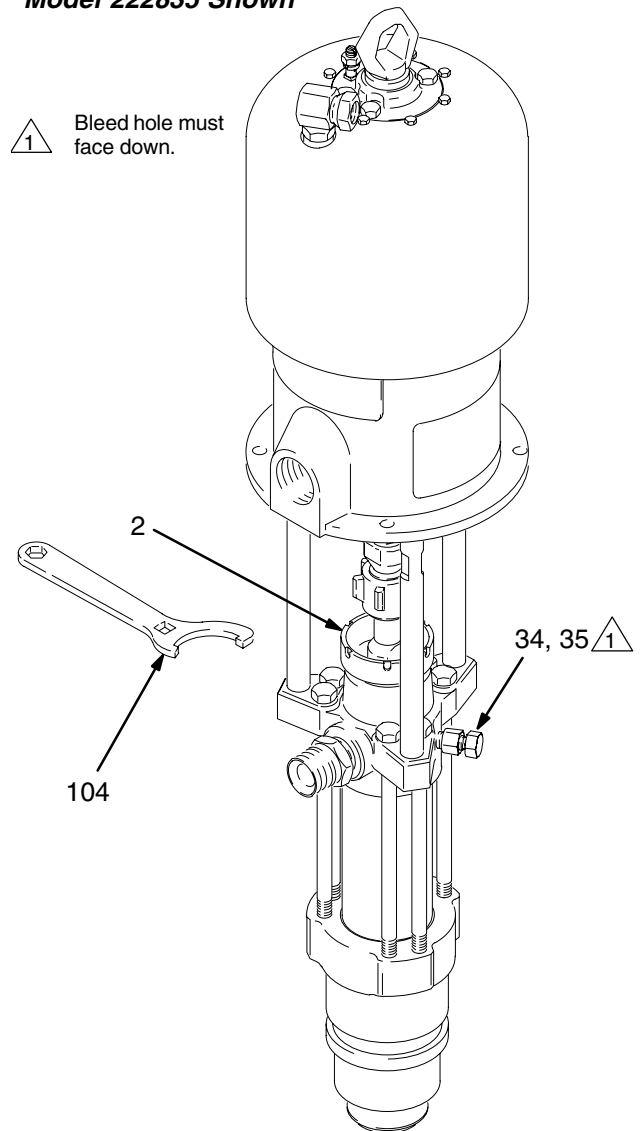

**Fig. 5**

0913A

# Operation

## (HYDRAULIC-POWERED MODELS)

### Starting and Adjusting the Pump

Supply fluid to the pump, per the requirements of your system.

Refer to Fig. 4 on page 10. Check the hydraulic fluid level before each use, and add fluid as necessary. Make certain that the supply line shutoff valve (U) and the return line shutoff valve (V) are closed, then start the hydraulic power supply.

Hold a metal part of the gun/valve (S) firmly to the side of a grounded metal pail and hold the trigger open.

Open the return line shutoff valve (V) *first*, then slowly open the supply line shutoff valve (U).

Cycle the pump slowly until all the air is pushed out and the pump and hoses are fully primed. Release the spray gun/dispensing valve trigger and engage the trigger safety. The pump should stall against pressure when the trigger is released.

If the pump fails to prime properly, open the bleeder valve (35) slightly. Use the bleed hole on the underside of the valve body (34) as a priming valve until the fluid appears at the hole. See Fig. 10. Close the plug (35).

**NOTE:** When changing fluid containers with the hose and gun already primed, open the bleeder valve plug (35), to assist in priming the pump and venting air before it enters the hose. Close the bleeder valve when all air has been eliminated.

### WARNING

To reduce the risk of fluid injection, do not use your hand or fingers to cover the bleed hole when priming the pump.

With the pump and lines primed, and with adequate hydraulic volume supplied, the pump will start and stop as the gun/valve is opened and closed. In a circulating system, the pump will speed up or slow down on demand, until the hydraulic power supply is shut off.

Use the fluid pressure gauge (F) and flow control valve (G) to control the pump speed and the fluid outlet pressure. Always use the lowest hydraulic flow and pressure necessary to get the desired results. Higher pressures cause premature tip/nozzle and pump wear.

### WARNING

To reduce the risk of overpressurizing your system, which could result in component rupture and cause serious injury, never exceed 10 MPa, 103 bar (1500 psi) Maximum Hydraulic Input Pressure to the pump or 15.9 MPa, 159 bar (2300 psi) Maximum Fluid Working Pressure (see the **Technical Data** on page 35).

To prevent overpressurizing the hydraulic motor or its seals, always shut off the supply line valve (U) first, then shut off the return line valve (V).

### CAUTION

Do not allow the hydraulic oil temperature to exceed 54° C (130° F). The pump seals will wear faster and leakage may occur if the pump is operated at higher oil temperatures.

Never allow the pump to run dry of the fluid being pumped. A dry pump will quickly accelerate to a high speed, possibly damaging itself. If your pump accelerates quickly, or is running too fast, stop it immediately and check the fluid supply. If the supply container is empty and air has been pumped into the lines, refill the container and prime the pump and the lines with fluid, or flush and leave it filled with a compatible solvent. Be sure to eliminate all air from the fluid system.

### Shutdown and Care of the Pump

### WARNING

To reduce the risk of serious injury whenever you are instructed to relieve pressure, always follow the **Pressure Relief Procedure** on page 12.

For overnight shutdown, **relieve the pressure**. Stop the pump at the bottom of the stroke to prevent fluid from drying on the exposed displacement rod and damaging the throat packings.

Always flush the pump before the fluid dries on the displacement rod. Never leave water or water-based fluid in the pump overnight. First, flush with water or a compatible solvent, then with mineral spirits. Relieve the pressure, but leave the mineral spirits in the pump to protect the parts from corrosion.

# Troubleshooting

## WARNING

To reduce the risk of serious injury whenever you are instructed to relieve pressure, always follow the **Pressure Relief Procedure** on page 12.

1. **Relieve the pressure.**
2. Check all possible causes and problems before disassembling the pump.

PROBLEM	CAUSE	SOLUTION
Pump fails to operate	Restricted line or inadequate air/hydraulic supply; closed or clogged valves	Clear; increase air/hydraulic supply. Check that valves are open.
	Obstructed fluid hose or gun/valve; fluid hose ID is too small	Open, clear*; use hose with larger ID.
	Fluid dried on the displacement rod	Clean; always stop pump at bottom of stroke; keep wet-cup 1/3 filled with compatible solvent.
	Dirty, worn, or damaged motor parts	Clean or repair; see separate motor manual.
Pump operates, but output low on both strokes	Restricted line or inadequate air/hydraulic supply; closed or clogged valves	Clear; increase air/hydraulic supply. Check that valves are open.
	Obstructed fluid hose or gun/valve; fluid hose ID is too small	Open, clear*; use hose with larger ID.
	Bleeder valve open	Close.
	Air leaking into supply container	Check ram plate seal.
	Fluid too heavy for pump priming	Use bleeder valve (see pages 12 and 14); use ram.
	Worn packings in displacement pump	Replace packings.
Pump operates, but output low on downstroke	Fluid too heavy for pump priming	Use bleeder valve (see pages 12 and 14); use ram.
	Held open or worn intake valve or seals	Clear valve; replace seals.
Pump operates, but output low on upstroke	Held open or worn piston valve or seals	Clear valve; replace seals.
Erratic or accelerated pump speed	Exhausted fluid supply	Refill and prime.
	Fluid too heavy for pump priming	Use bleeder valve (see pages 12 and 14); use ram.
	Held open or worn piston valve or seals	Clear valve; replace seals.
	Held open or worn priming piston	Clear; service.
	Worn packings in displacement pump	Replace packings.

\* To determine if the fluid hose or gun is obstructed, **relieve the pressure**. Disconnect the fluid hose and place a container at the pump fluid outlet to catch any fluid. Turn on the air/hydraulic power just enough to start the pump. If the pump starts when the air/hydraulic power is turned on, the obstruction is in the fluid hose or gun.

**NOTE:** If you experience air motor icing, contact your Graco distributor.

# Service

## WARNING

To reduce the risk of serious injury whenever you are instructed to relieve pressure, always follow the **Pressure Relief Procedure** on page 12.

### Required Tools

- Torque wrench
- Bench vise, with soft jaws
- Rubber mallet
- Hammer
- O-ring pick
- 13 mm (1/2 in.) dia. brass rod
- Set of socket wrenches
- Set of adjustable wrenches
- 24 in. adjustable wrench
- Thread lubricant
- Thread sealant
- Loctite® 2760™ or equivalent

**NOTE:** Service Tool 109508 is available as an accessory. The tool fits over the top of the displacement rod, making it easier to apply a 24 inch adjustable wrench or 3/4 in. drive socket when connecting or disconnecting the rod from the piston assembly.

### Disconnecting the Displacement Pump

## WARNING

Keep hands and fingers away from the priming piston during operation and whenever the pump is charged with air/hydraulic fluid to reduce the risk of injury! On the pump downstroke the priming piston extends beyond the intake housing to pull the material into the pump. The priming piston works under extreme force. During operation and whenever the pump is charged with air/hydraulic fluid, the priming piston can severely injure or amputate a hand or finger, or break a tool, caught between it and the intake housing. Always **relieve the pressure** before checking, clearing, cleaning, flushing, or servicing any part of the pump.

On King and Bulldog air-powered pumps, the air motor piston (located behind the air motor shield) moves when air is supplied to the motor. Never operate the pump with the air motor shield removed.

On Premier air-powered pumps, the rocker arms (located beneath the rocker arm covers) move when air is supplied to the motor. Never operate the pump with the rocker arm covers removed.

Before servicing the pump, **relieve the pressure** to prevent the pump from starting accidentally.

1. Flush the pump, if possible. Stop the pump at the bottom of its stroke. **Relieve the pressure.**
2. Disconnect the air or hydraulic hose. Plug all hydraulic hoses immediately, to prevent contamination of the hydraulic system. Hold the fluid outlet fitting (20) with a wrench to keep it from being loosened while you disconnect the fluid hose.
3. Disconnect the displacement pump (105) from the motor (101) as follows. Be sure to note the relative position of the pump's fluid outlet to the air or hydraulic inlet of the motor. If the motor does not require servicing, leave it attached to its mounting.

## CAUTION

Be sure to use at least two people when lifting, moving, or disconnecting the pump. This pump is too heavy for one person. If you are disconnecting the displacement pump from a motor which is still mounted (for example, on a ram), be sure to support the displacement pump while it is being disconnected, to prevent it from falling and causing injury or property damage. Do this by securely bracing the pump, or by having at least two people hold it while another disconnects it.

4. Using an adjustable wrench, unscrew the coupling nut (103). Remove the coupling collars (108). Take care not to lose or drop them. See Fig. 6.
5. Hold the tie rod flats with a wrench to keep the rods from turning. Unscrew the nuts (106) from the tie rods (107). Carefully remove the displacement pump (105) from the motor (101).
6. Refer to page 19 for displacement pump service. To service the air or hydraulic motor, refer to the separate motor manual, supplied.



# Service

King, Bulldog, and  
Viscount Pumps  
(Model 222835  
Shown)

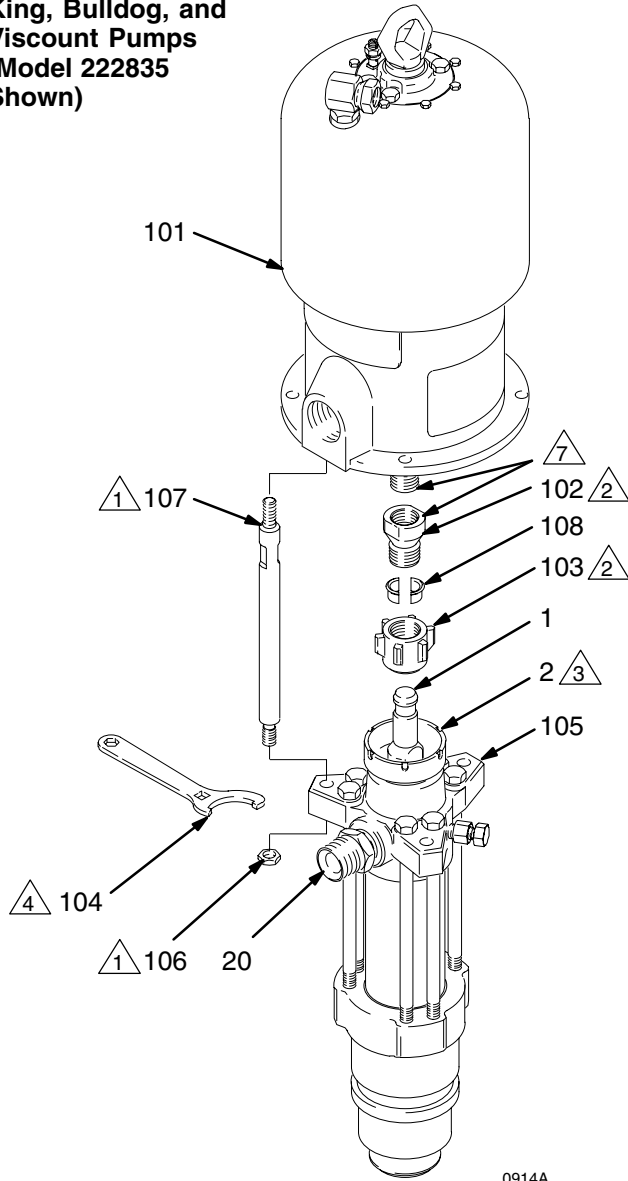

0914A

Premier Pumps  
(Model 222940  
Shown)

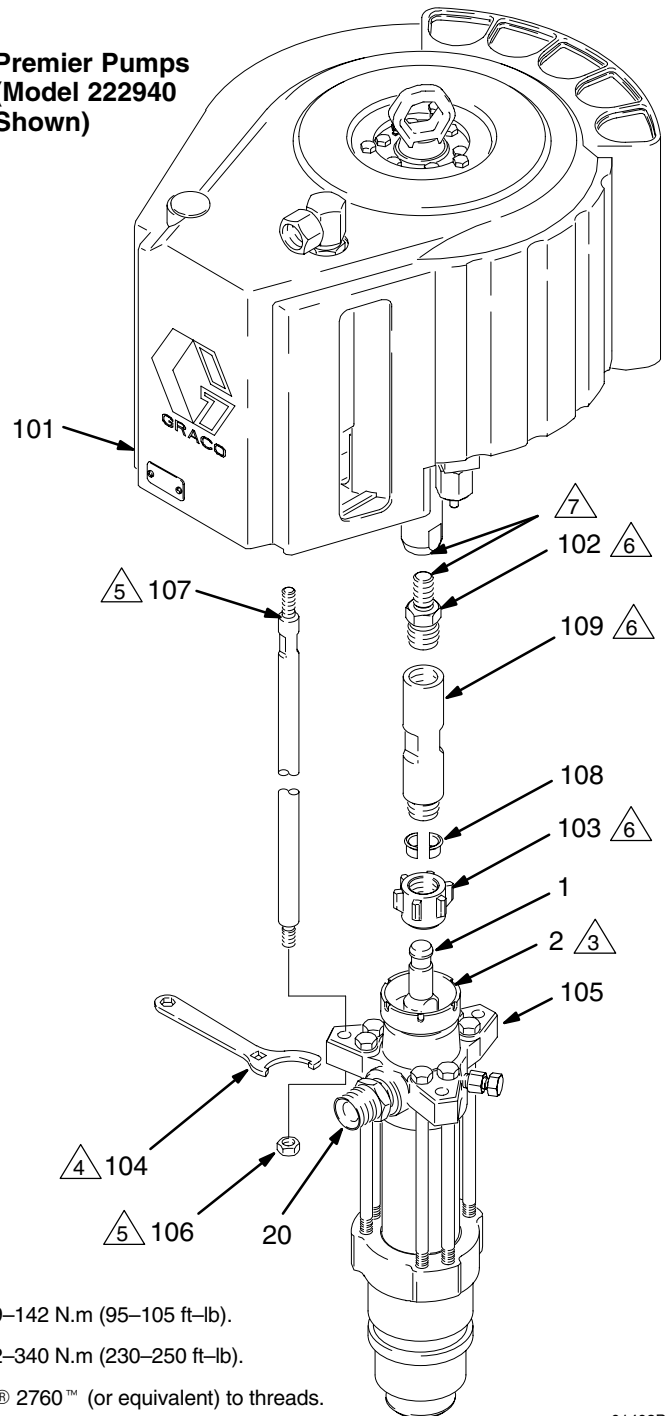

01403B

1 Torque to 129–142 N.m (95–105 ft-lb).

2 Torque to 196–210 N.m (145–155 ft-lb).

3 Torque to 135–169 N.m (100–125 ft-lb).

4 Square hole is for use with torque wrench.

5 Torque to 129–142 N.m (95–105 ft-lb).

6 Torque to 312–340 N.m (230–250 ft-lb).

7 Apply Loctite® 2760™ (or equivalent) to threads.

Fig. 6

# Service

## Reconnecting the Displacement Pump

### CAUTION

Be sure to use at least two people when lifting, moving, or disconnecting the pump. This pump is too heavy for one person. If you are disconnecting the displacement pump from a motor which is still mounted (for example, on a ram), be sure to support the displacement pump while it is being disconnected, to prevent it from falling and causing injury or property damage. Do this by securely bracing the pump, or by having at least two people hold it while another disconnects it.

**NOTE:** On Premier models, ensure that the rod adapter (102) has not loosened during maintenance. Proper torque is necessary to prevent the rod adapter from loosening during the pump operation.

If the rod adapter (102) has loosened during maintenance, remove the adapter and apply Loctite® 2760™ (or equivalent) to the rod adapter and air motor piston threads, and then torque as specified in Fig. 6.

1. Use at least two people to hold the displacement pump while another reconnects it to the motor (see the **CAUTION** above). Orient the pump's fluid outlet to the air or hydraulic inlet as was noted in step 3 under **Disconnecting the Displacement Pump**. Position the displacement pump (105) on the tie rods (107). See Fig. 6.
2. Screw the nuts (106) onto the tie rods (107) and torque as noted in Fig. 6.
3. Place the coupling nut (103) on the displacement rod (1), then place the coupling collars (108) into the nut. Loosely screw the coupling nut onto the connecting rod adapter (102) or connecting rod (109, Model 222940 only). Hold the adapter or connecting rod flats with a wrench to keep it from turning. Use an adjustable wrench to tighten the coupling nut. Torque as noted in Fig. 6.
4. Torque the packing nut (2) to 135–169 N.m (100–125 ft-lb).
5. Reconnect all hoses. Reconnect the ground wire if it was disconnected. Fill the wet-cup (2) 1/3 full of Graco Throat Seal Liquid or compatible solvent.
6. Turn on the air or hydraulic power supply. On hydraulic pumps, open the hydraulic return line valve *first*, then the supply line valve. Run the pump slowly to ensure that it is operating properly.

# Service

## Displacement Pump Disassembly

When disassembling the pump, lay out all the removed parts in sequence, to ease reassembly. Clean all parts with a compatible solvent and inspect them for wear or damage. Refer to Fig. 10.

**NOTE:** Repair Kit 222860 is available to replace the packings and seals. Parts included are denoted with an asterisk, for example (7\*). Repair Kit 222974 is available to repair the intake valve. Parts included are denoted with a symbol, for example (10†). For the best results, use all the new parts in the kits. Conversion Kit 222861 is available to convert the pump to all PTFE v-packings, and Conversion Kit 222862 is available to convert to leather v-packings. See page 29.

1. Remove the displacement pump from the air motor as explained on page 16.
2. Hold the flats of the priming piston rod (12) with an adjustable wrench, and use a second wrench to unscrew the priming piston nut (14) from the rod. Slide the priming piston (15) and guide (13) off the rod. Inspect the outer surface of the guide (13) and the inner and outer surfaces of the piston (15) for scoring, wear, or other damage.
3. Stand the pump upright in a vise. Loosen the packing nut (2) using the packing nut wrench (104) supplied, or a hammer and brass rod. Using a socket wrench, remove the six capscrews (32).
4. Tap the underside of the outlet housing (19) with a rubber mallet to loosen the housing from the cylinder (4). Lift the outlet housing off the pump and set it aside. Be careful not to scratch the displacement rod (1) while removing the housing. Remove the seal (39) from the top of the cylinder.
5. Lift the cylinder (4) up off the intake housing (17). The displacement rod (1), piston assembly, intake valve assembly, and priming piston rod (12) will come with the cylinder.
6. Place the cylinder (4) sideways in a vise with soft jaws. Using a rubber mallet on the end of the priming piston rod (12), drive the displacement rod (1) and piston assembly out the top of the cylinder. Continue to pull the rod out of the cylinder until the priming piston rod (12) comes free.
7. Remove the seal (39) from the bottom of the cylinder (4). Hold the cylinder up to the light at an angle to examine the inside surface for scoring or damage.

8. Place the flats of the displacement rod (1) in a vise. Using a 13 mm (1/2 in.) diameter brass rod, pry the intake check valve assembly away from the rod guide (18) far enough to apply wrenches to the valve assembly. See Fig. 7.

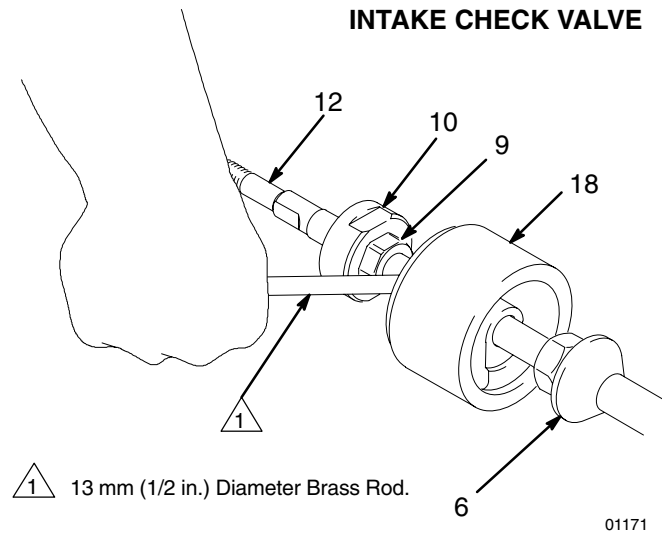

Fig. 7

9. Hold the valve body (10) steady with a wrench on the flats. Using an adjustable wrench, loosen the intake packing nut (9) to decrease tension on the priming piston rod (12). Now slide the intake valve assembly off the rod and set it aside. See Fig. 8.

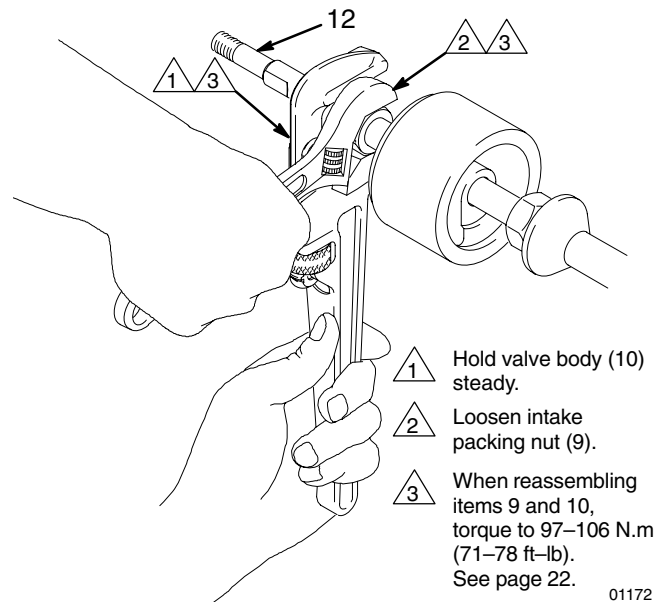

Fig. 8

# Service

10. Pull the seal (39) and seat (11) out the top of the intake housing (17). See Fig. 10. If the seat is difficult to remove, turn the housing upside down and drive the seat out using a hammer and brass rod.
11. Examine the mating surfaces of the seat (11) and the intake valve body (10) for damage.
12. Slide the rod guide (18) off the priming piston rod (12). Unscrew the priming piston rod from the piston (6). Run a finger over the surface of the rod to check for scratches or scoring.

**NOTE:** Service Tool 109508 is available as an accessory. The tool fits over the top of the displacement rod (1), making it easier to apply a 24 inch adjustable wrench or 3/4 in. drive socket when disconnecting the rod from the piston (6).

13. Place the flats of the piston (6) in a vise. Unscrew the displacement rod (1) from the piston (6). Lift the piston seat and guide assembly off the piston. Inspect the mating surfaces of the piston (6) and piston seat (8) for damage. See the Detail in Fig. 10.
14. Remove the displacement rod (1) from the vise and inspect it for scratches and scoring by running a finger over the surface.
15. Place the piston seat and guide assembly in the vise and close the jaws on the flats of the seat (8) just tight enough to hold the part. Slide a brass rod through the openings in the piston guide (5) and unscrew it from the seat as shown in Fig. 9. Remove the piston seal (7).

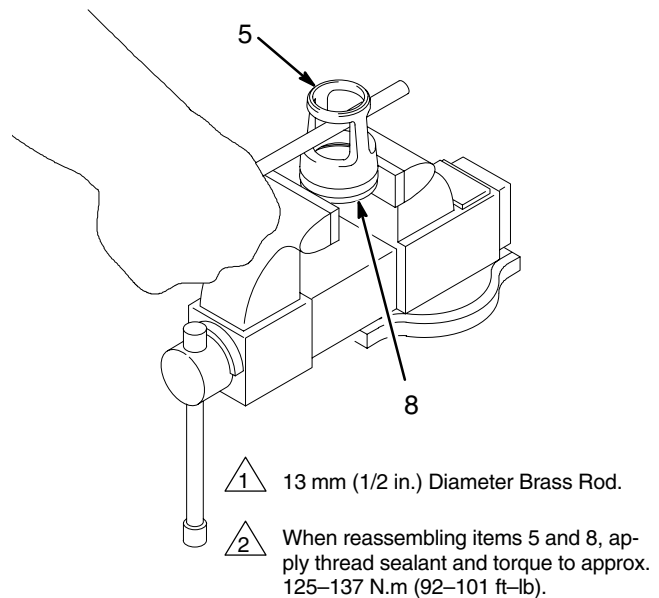

**Fig. 9**

01173

16. Take the intake valve assembly removed in step 9 and unscrew the packing nut (9) from the valve body (10). Using an o-ring pick, remove the glands (16, 41) and v-packings (40 and 42) from the valve body. Remove the seal (43) from the packing nut. See the Detail in Fig. 10.

**NOTE:** The seal (43) is press-fit in the packing nut and may require cutting to ease removal.

17. Unscrew the bleeder valve plug (35) completely from the valve housing (34). Clean the valve threads and the bleed hole in the valve housing. It is not necessary to remove the valve housing from the outlet housing (19).
18. Remove the packing nut (2) from the outlet housing (19). Remove the throat packings (22, 24) and glands (21, 23) from the outlet housing (19). **Do not** remove the fluid outlet nipple (20) and o-ring (25) from the outlet housing unless they need replacement.
19. Inspect all parts for damage. Clean all parts and threads with a compatible solvent. Reassemble as explained on page 22.

# Service

## THROAT PACKING DETAIL

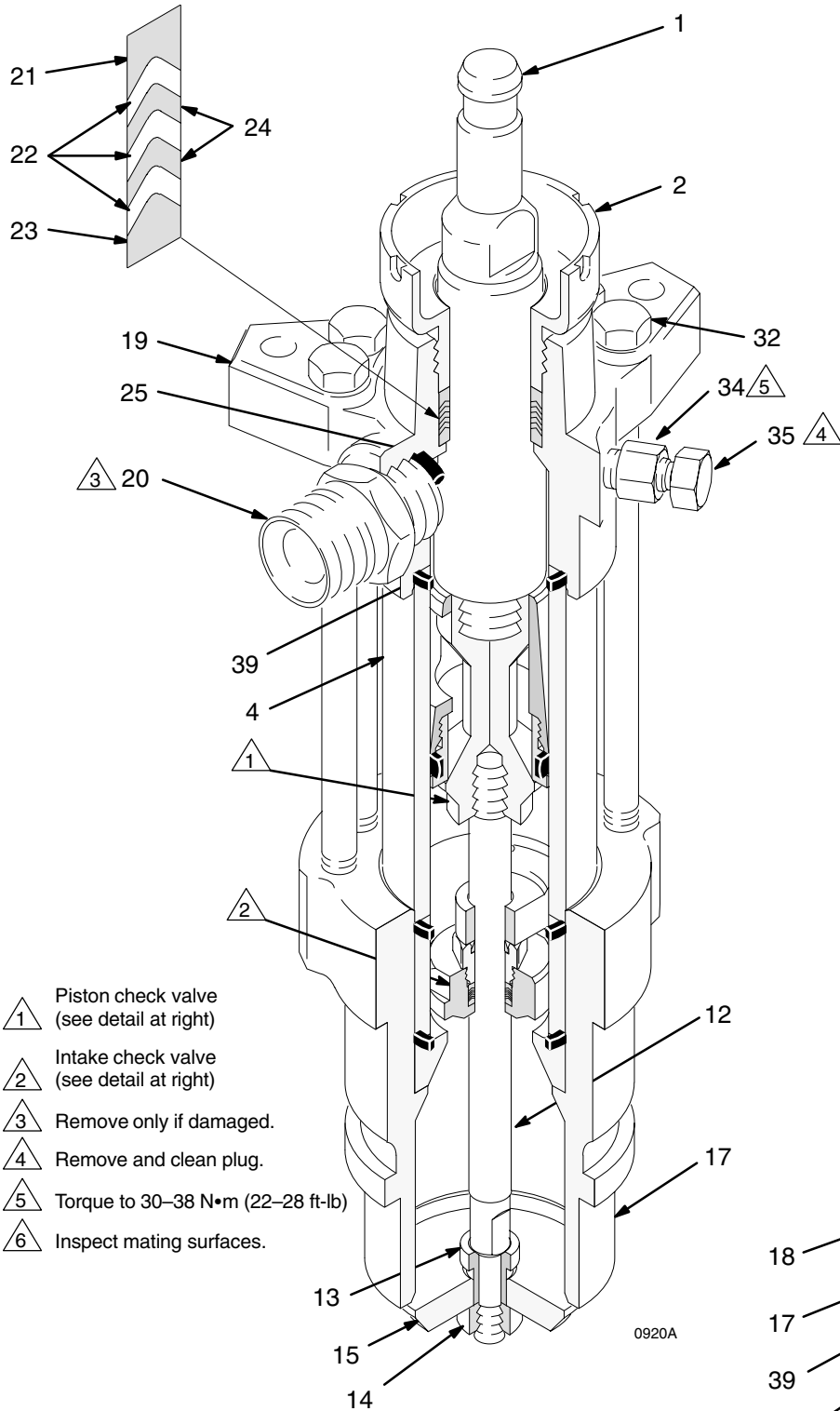

- △ 1 Piston check valve (see detail at right)
- △ 2 Intake check valve (see detail at right)
- △ 3 Remove only if damaged.
- △ 4 Remove and clean plug.
- △ 5 Torque to 30–38 N•m (22–28 ft-lb)
- △ 6 Inspect mating surfaces.

## DETAIL OF PISTON CHECK VALVE

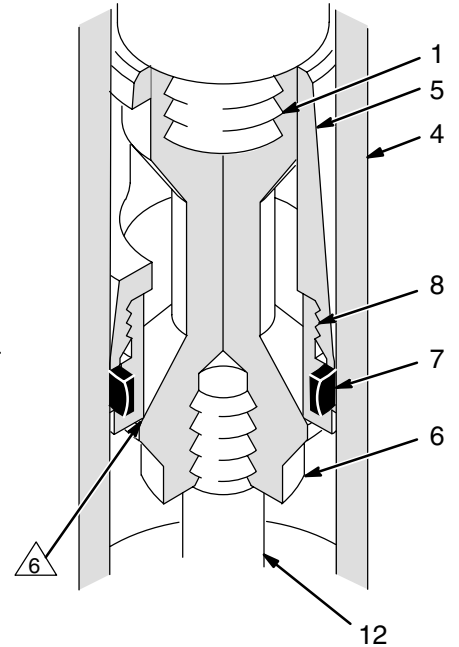

01120

## DETAIL OF INTAKE CHECK VALVE

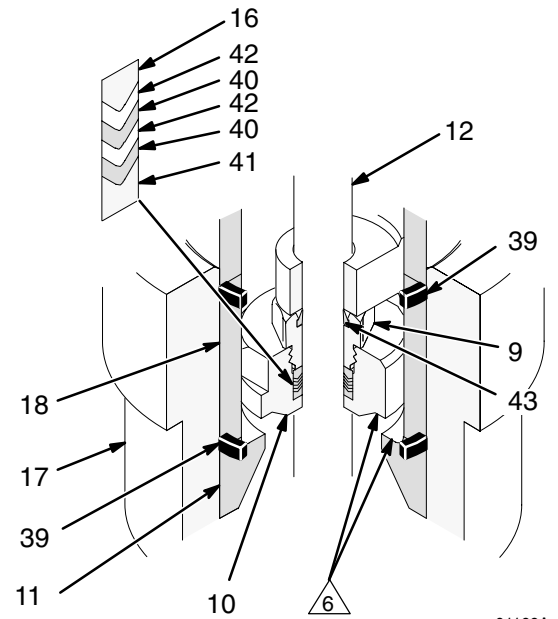

01166A

Fig. 10

# Service

## Reassembly

Refer to Fig. 11 for reassembly.

1. Install the intake valve seat (11†) in the intake housing (17), with the large bevel of the seat facing the bottom of the housing. Lubricate the seal (39\*†) and install it in the housing. Set the intake housing aside.
  2. Install the piston seal (7\*) on the piston seat (8). Place the seat in a vise and close the jaws tight enough to hold it securely, without placing too much stress on the part. Apply thread sealant to the threads of the seat and the piston guide (5). Screw the guide onto the seat (8). Tighten using a brass rod until the guide is securely seated, approximately 125–137 N.m (92–101 ft–lb). See Figs. 9 and 11.
  3. Place the flats of the piston (6) in a vise. Apply thread sealant to the threads of the rod (1) and the top threads of the piston. Set the piston seat/guide assembly onto the piston.
- NOTE:** Service Tool 109508 is available as an accessory. The tool fits over the top of the displacement rod (1), making it easier to apply a 24 inch adjustable wrench or 3/4 in. drive socket when connecting the rod to the piston (6).
4. Screw the rod (1) into the piston (6) hand tight. Torque the rod to 459–481 N.m (338–354 ft–lb). There will be a small gap between the top of the piston (6) and the shoulder of the rod (1).
  5. Apply thread sealant to the bottom threads of the piston and the top threads of the priming piston rod (12). Using an adjustable wrench on the flats of the rod, screw the rod into the piston. Torque to 125–137 N.m (92–101 ft–lb). Be careful not to create burrs on the flats of the rod.
  6. Slide the rod guide (18) onto the priming piston rod (12), making certain that the end nearest the valve stop (VS) goes on the rod first. See the Detail in Fig. 11.
  7. With the beveled side facing up, press the seal (43\*) into the recess of the intake packing nut (9) until it snaps into place. The nose of the seal should be flush with or slightly recessed into the face of the packing nut.

8. Lubricate the intake valve packings and the inner diameter of the valve body (10†). Install the packings one at a time in the following order, **with the lips of the v-packings facing up:** the female gland (41\*), one PTFE v-packing (40\*), one UHMWPE v-packing (42\*), PTFE(40\*), UHMWPE (42\*), and the male gland (16\*). Screw the intake packing nut (9) into the valve body (10) handtight. See the Detail in Fig. 11.
9. Slide the assembled intake valve onto the priming piston rod (12), making certain that the packing nut (9) goes on the rod first. Push the valve assembly up the rod, stopping before it reaches the rod guide (18).
10. Hold the valve body (10) steady with a wrench while using an adjustable wrench to tighten the packing nut (9). See Fig. 8. Torque to 97–106 N.m (71–78 ft–lb). Use a hammer and brass rod to carefully drive the valve assembly further up the rod until it reaches the stop (VS).
11. Remove the displacement rod (1) from the vise. Place the cylinder (4) sideways in the vise with soft jaws.
12. Lubricate the seal (39\*) and place it on the bottom of the cylinder (4). (The cylinder is symmetrical, so either end can be the bottom.) See Fig. 11.
13. Slide the displacement rod (1), piston assembly, intake valve assembly, and priming piston rod (12) into the cylinder (4) from the bottom, until the mating surfaces of the rod guide (18) and cylinder (4) meet.
14. Put the intake housing (17) upright in a vise, making sure it is off-center so there is sufficient clearance for the priming piston rod (12) to be lowered through the housing. Take the rod and cylinder assembly and lower it into the intake housing until the rod guide (18) bottoms on the intake seat (11) and the priming piston rod (12) protrudes from the bottom of the intake housing (17).
15. Screw the bleeder valve plug (35) into the valve housing. The plug has two sets of threads. When reassembling, be sure to screw the plug fully into the valve housing.

**NOTE:** It is not ordinarily necessary to remove the outlet nipple (20) and o-ring (25\*). However, if they were replaced because of damage, lubricate the o-ring (25\*) and place it on the nipple (20). Screw the nipple into the outlet housing (19). Torque to 156–171 N.m (115–126 ft–lb).

# Service



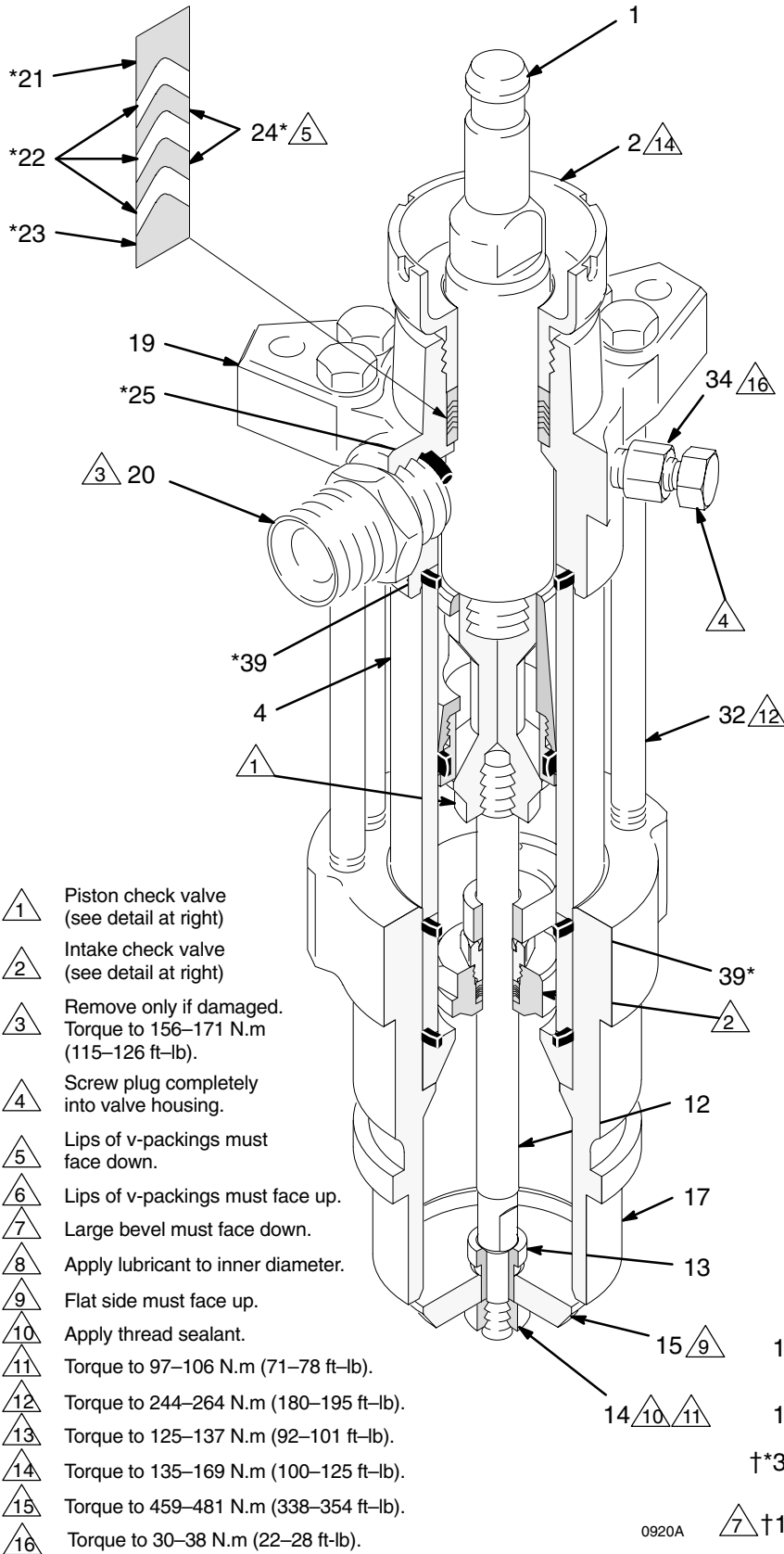



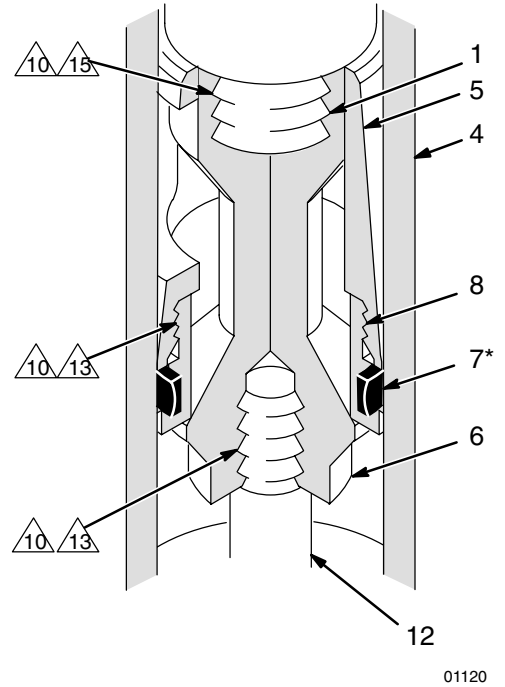









## THROAT PACKING DETAIL



## DETAIL OF PISTON CHECK VALVE



01120

-  1 Piston check valve (see detail at right)
-  2 Intake check valve (see detail at right)
-  3 Remove only if damaged. Torque to 156–171 N.m (115–126 ft-lb).
-  4 Screw plug completely into valve housing.
-  5 Lips of v-packings must face down.
-  6 Lips of v-packings must face up.
-  7 Large bevel must face down.
-  8 Apply lubricant to inner diameter.
-  9 Flat side must face up.
-  10 Apply thread sealant.
-  11 Torque to 97–106 N.m (71–78 ft-lb).
-  12 Torque to 244–264 N.m (180–195 ft-lb).
-  13 Torque to 125–137 N.m (92–101 ft-lb).
-  14 Torque to 135–169 N.m (100–125 ft-lb).
-  15 Torque to 459–481 N.m (338–354 ft-lb).
-  16 Torque to 30–38 N.m (22–28 ft-lb).

## DETAIL OF INTAKE CHECK VALVE

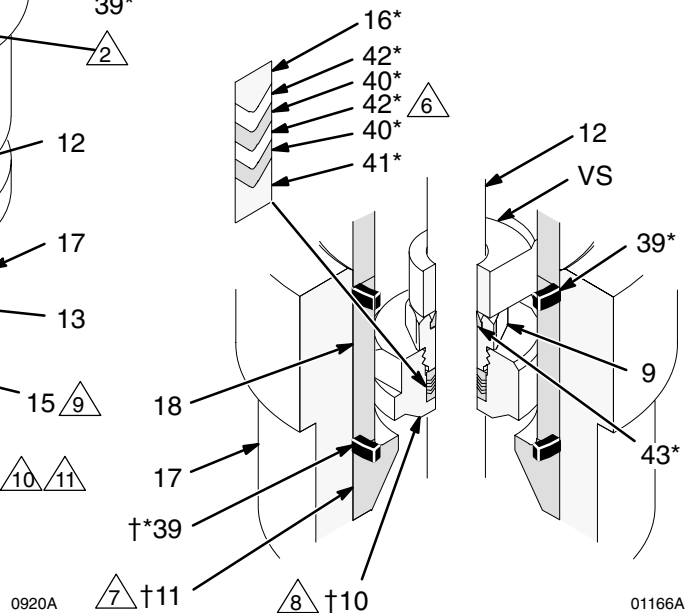

01166A

Fig. 11

# Service

16. Lubricate the throat packings and glands, and install them in the outlet housing (19) one at a time in the following order, **with the lips of the v-packings facing down**: the male gland (23\*), one UHMWPE v-packing (22\*), one PTFE v-packing (24\*), UHMWPE (22\*), PTFE(24\*), UHMWPE (22\*), and the female gland (21\*). Apply thread lubricant to the packing nut (2) and install it loosely in the outlet housing.
17. Lubricate the seal (39\*) and place it on the top edge of the cylinder (4). Set the outlet housing (19) on top of the cylinder.
18. Install the six long capscrews (32) through the outlet housing (19) and into the intake housing (17). Using a socket wrench, torque the screws oppositely and evenly to 244–264 N.m (180–195 ft–lb). Remove the pump from the vise and place it on its side.
19. Check that the flats of the priming piston rod (12) are accessible below the intake housing (17). If not, tap on the top of the displacement rod (1) with a rubber mallet, until the flats are exposed.
20. Slide the priming piston guide (13) onto the rod (12) until it stops. Then install the priming piston (15), with the flat side facing up toward the pump. Apply thread sealant to the threads of the priming piston nut (14). Hold the rod (12) steady with an adjustable wrench on the flats, and screw the nut (14) onto the rod with another wrench. Torque to 97–106 N.m (71–78 ft–lb). See Fig. 12.

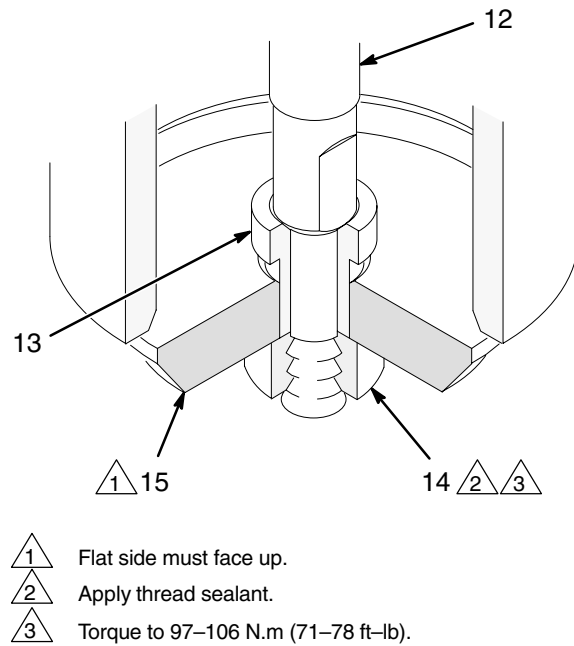

01165

Fig. 12

21. Reconnect the displacement pump to the air motor as explained on page 18.
22. Allow 2 hours for the thread sealant to cure before returning the pump to service.



# Parts

**Model 222828 Pump, Series A  
Model 246935 Pump, Series A  
12:1 Ratio, with Bulldog Air Motor**

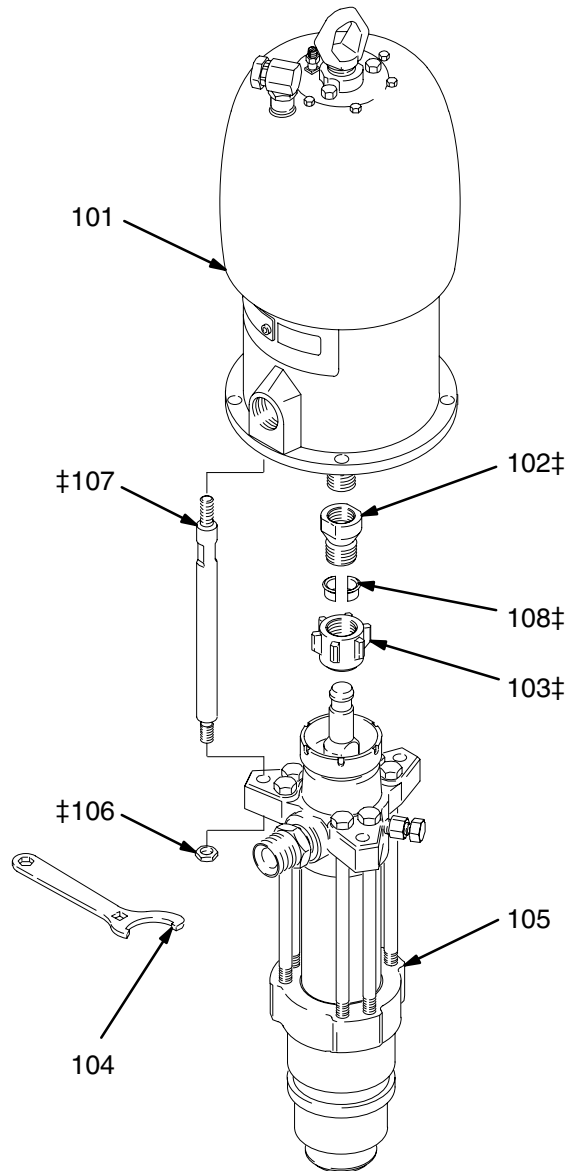

**Model 222829 Pump, Series A  
12:1 Ratio, with Quiet Bulldog Air Motor**

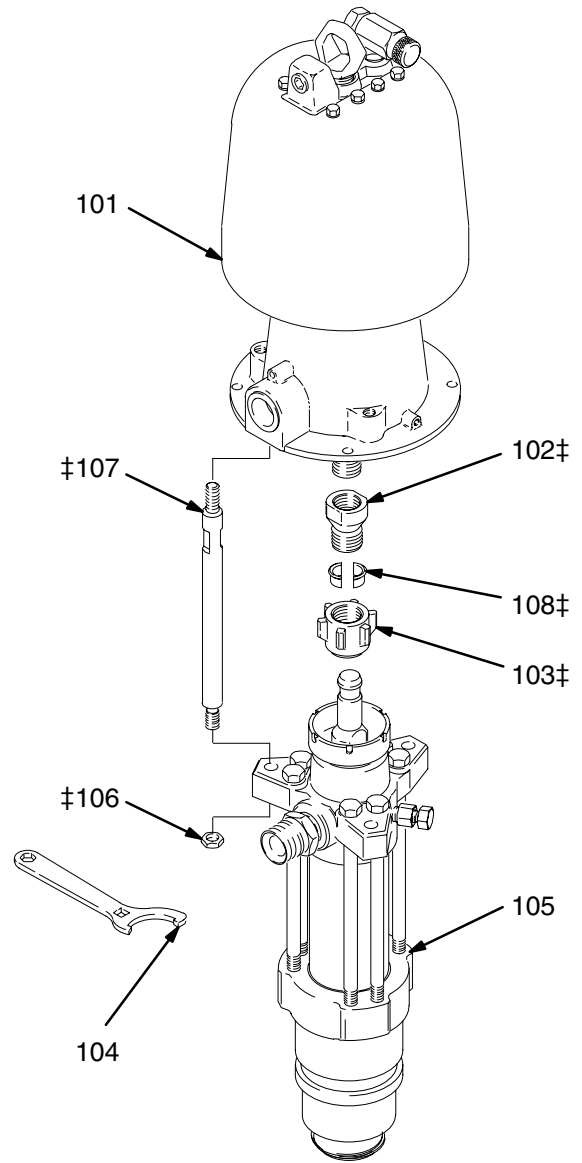

Ref No.	Part No.	Description	Qty
101	208356	AIR MOTOR, Bulldog See 307049 for parts	1
102‡	184451	ADAPTER, connecting rod	1
103‡	184096	NUT, coupling	1
104	184278	WRENCH, packing nut	1
105	222810	PUMP, displacement (222828 only) See pages 28–29 for parts	1
105	246934	PUMP, displacement (246935 only) See pages 28–29 for parts	1
106‡	106166	NUT, hex; M16 x 2.0	3
107‡	184452	ROD, tie; 265 mm (10.43") shoulder to shoulder	3
108‡	184130	COLLAR, coupling	2

‡ These parts are included in Connection Kit 235414, which may be purchased separately.

Ref No.	Part No.	Description	Qty
101	215255	AIR MOTOR, Bulldog, quiet See 307304 for parts	1
102‡	184451	ADAPTER, connecting rod	1
103‡	184096	NUT, coupling	1
104	184278	WRENCH, packing nut	1
105	222810	PUMP, displacement See pages 28–29 for parts	1
106‡	106166	NUT, hex; M16 x 2.0	3
107‡	184452	ROD, tie; 265 mm (10.43") shoulder to shoulder	3
108‡	184130	COLLAR, coupling	2

‡ These parts are included in Connection Kit 235414, which may be purchased separately.

# Parts

**Model 222835 Pump, Series B  
Model 246936 Pump, Series A  
24:1 Ratio, with King Air Motor**

**Model 222901 Pump, Series B  
24:1 Ratio, with Quiet King Air Motor**

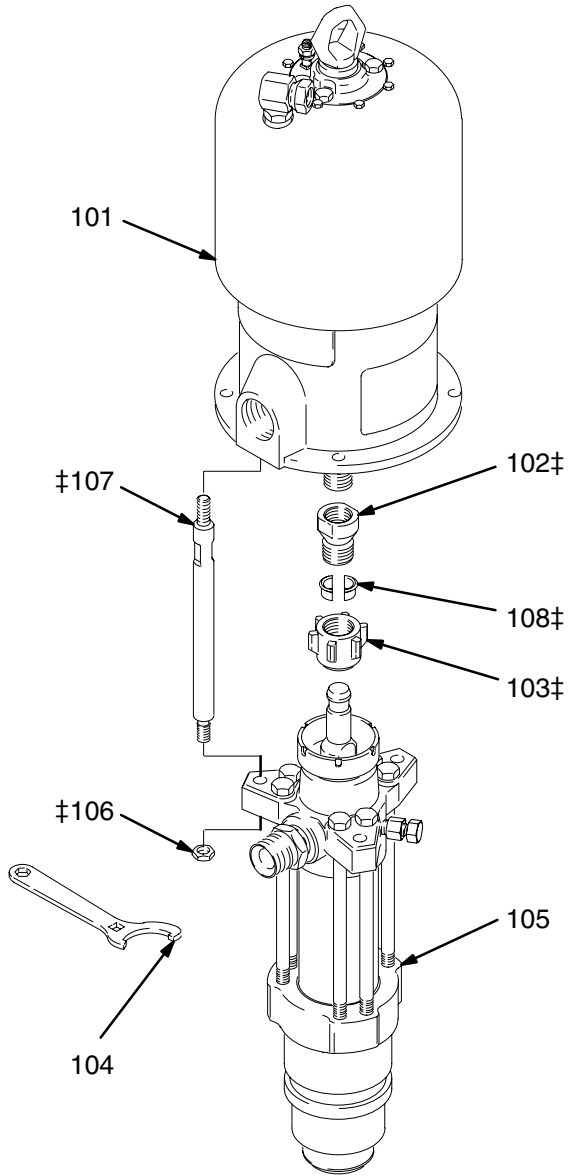

0914A

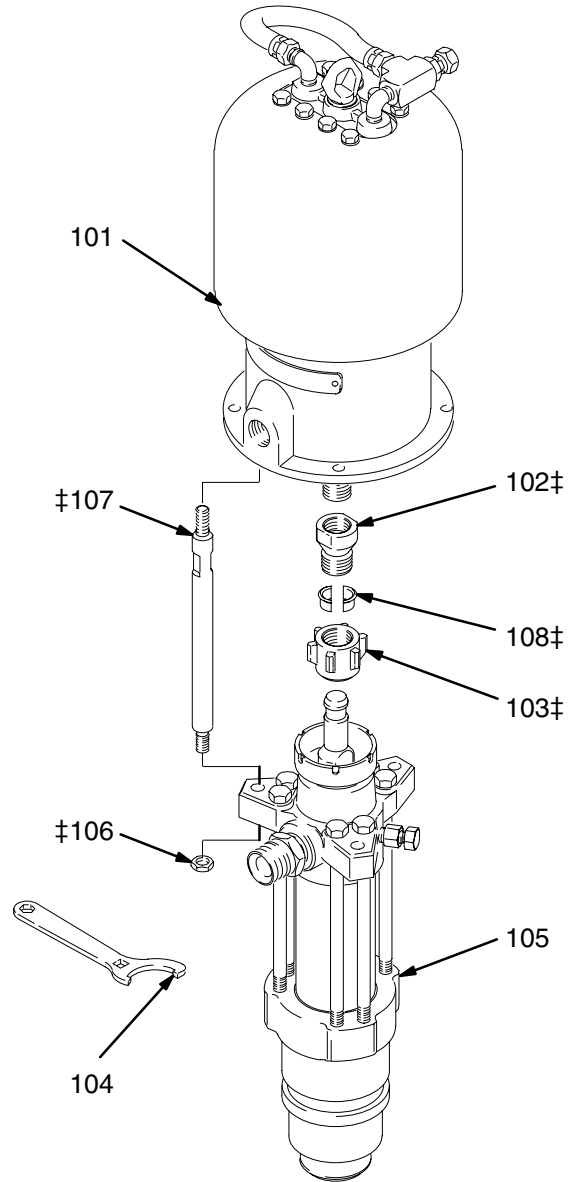

0915A

Ref No.	Part No.	Description	Qty
101	245111	AIR MOTOR, King See 309347 for parts	1
102‡	184451	ADAPTER, connecting rod	1
103‡	184096	NUT, coupling	1
104	184278	WRENCH, packing nut	1
105	222810	PUMP, displacement (222835 only) See pages 28–29 for parts	1
105	246934	PUMP, displacement (246936 only) See pages 28–29 for parts	1
106‡	106166	NUT, hex; M16 x 2.0	3
107‡	184452	ROD, tie; 265 mm (10.43") shoulder to shoulder	3
108‡	184130	COLLAR, coupling	2

‡ These parts are included in Connection Kit 235414, which may be purchased separately.

Ref No.	Part No.	Description	Qty
101	220106	AIR MOTOR, King, quiet See 309348 for parts	1
102‡	184451	ADAPTER, connecting rod	1
103‡	184096	NUT, coupling	1
104	184278	WRENCH, packing nut	1
105	222810	PUMP, displacement See pages 28–29 for parts	1
106‡	106166	NUT, hex; M16 x 2.0	3
107‡	184452	ROD, tie; 265 mm (10.43") shoulder to shoulder	3
108‡	184130	COLLAR, coupling	2

‡ These parts are included in Connection Kit 235414, which may be purchased separately.

# Parts

## Model 222940 Pump, Series A 39:1 Ratio, with Premier Air Motor

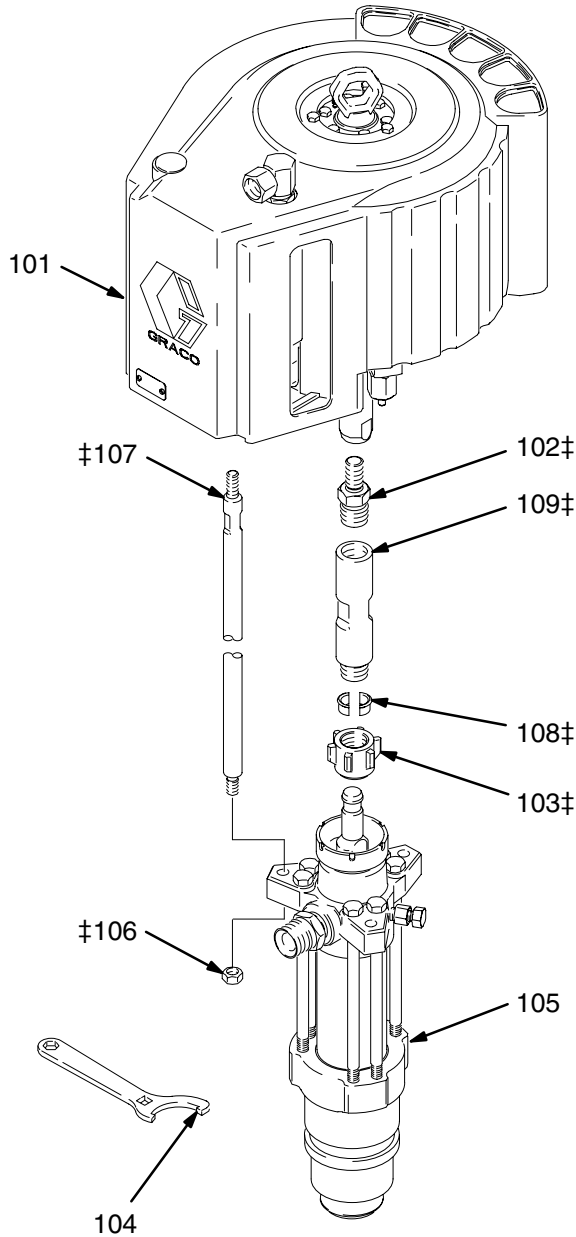

## Model 222902 Pump, Series B Model 246937 Pump, Series A with Viscount Hydraulic Motor

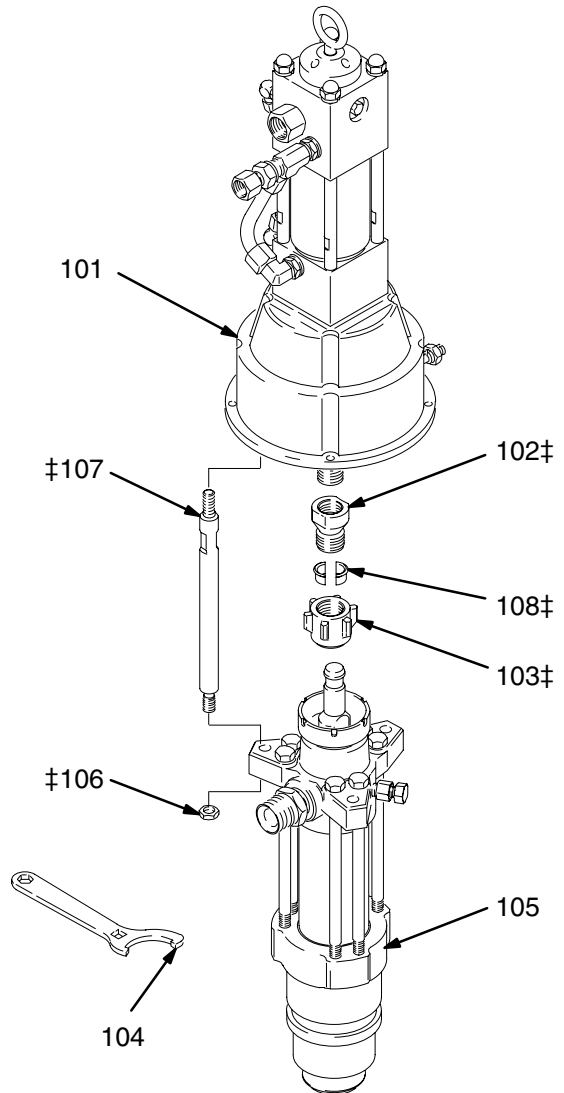

01403B

0916A

Ref No.	Part No.	Description	Qty	Ref No.	Part No.	Description	Qty
101	222800	AIR MOTOR, Premier See 308213 for parts	1	101	235345	HYDRAULIC MOTOR, Viscount See 307158 for parts	1
102‡	184582	ADAPTER, connecting rod	1	102‡	184595	ADAPTER, connecting rod	1
103‡	184096	NUT, coupling	1	103‡	184096	NUT, coupling	1
104	184278	WRENCH, packing nut	1	104	184278	WRENCH, packing nut	1
105	222810	PUMP, displacement See pages 28–29 for parts	1	105	222810	PUMP, displacement (222902 only) See pages 28–29 for parts	1
106‡	106166	NUT, hex; M16 x 2.0	3	105	246934	PUMP, displacement (246937 only) See pages 28–29 for parts	1
107‡	184381	ROD, tie; 560 mm (22.06") shoulder to shoulder	3	106‡	106166	NUT, hex; M16 x 2.0	3
108‡	184130	COLLAR, coupling	2	107‡	184596	ROD, tie; 315 mm (12.40") shoulder to shoulder	3
109‡	184556	ROD, connecting	1	108‡	184130	COLLAR, coupling	2

‡ These parts are included in Connection Kit 235421, which may be purchased separately.

‡ These parts are included in Connection Kit 222976, which may be purchased separately.

# Parts

Model 222810, Series B  
 Model 246934, Series A  
 Displacement Pump

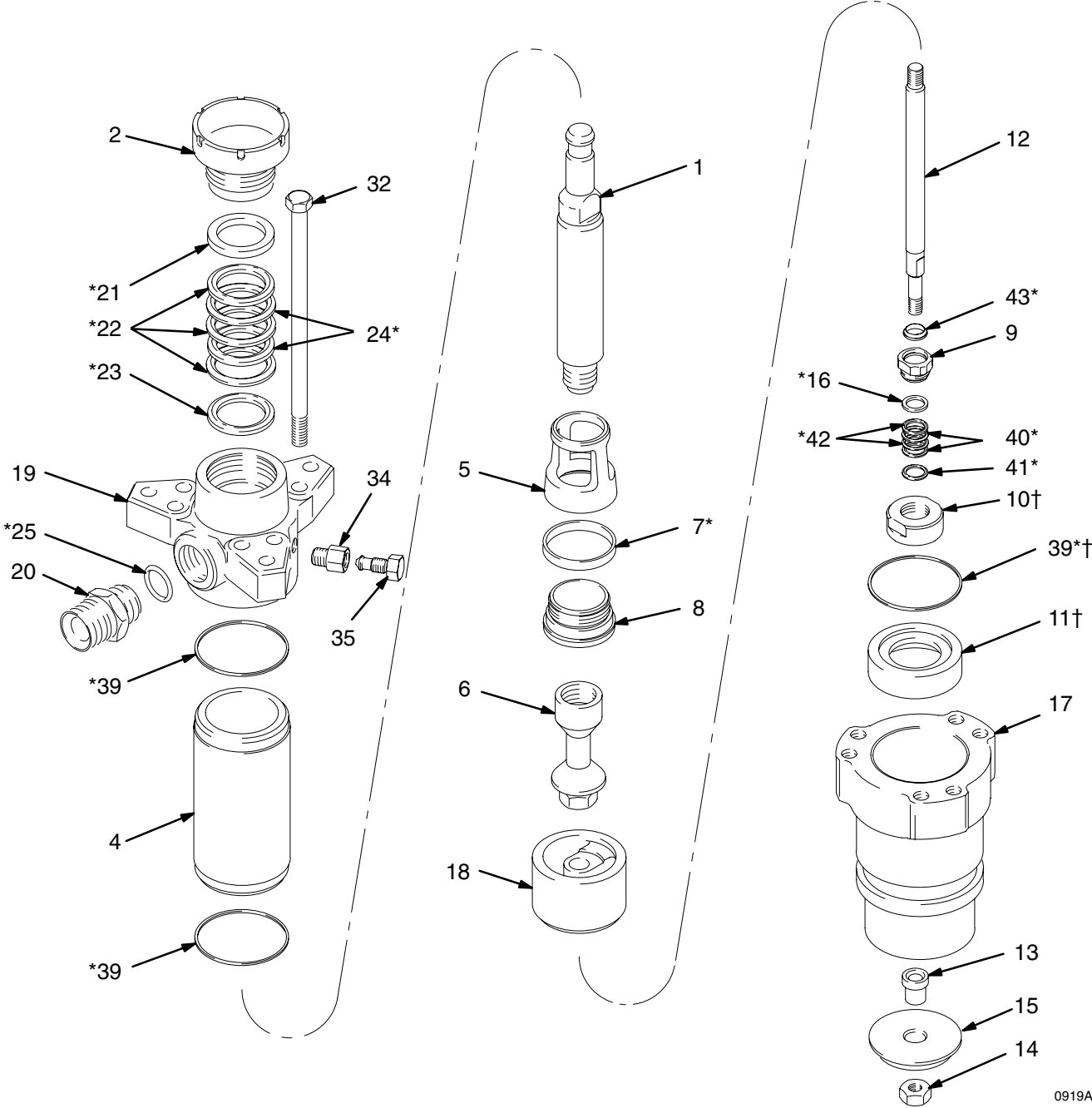

0919A

# Parts

## Model 222810, Series B Model 246934, Series A Displacement Pump

Ref No.	Part No.	Description	Qty
1	184002	ROD, displacement; sst	1
2	184006	PACKING NUT/WET-CUP; carbon steel (222810 only)	1
2	246965	PACKING NUT/WET-CUP; carbon steel (246934 only)	1
4	184393	CYLINDER, pump; sst	1
5	184394	GUIDE, piston; sst	1
6	184441	PISTON; sst	1
7*‡	184395	SEAL, piston; UHMWPE	1
8	184444	SEAT, piston; sst	1
9	189727	NUT, packing, intake valve; carbon steel	1
10†	184496	VALVE BODY, intake; carbon steel	1
11†	184495	SEAT, intake valve; carbon steel	1
12	184400	ROD, priming piston; sst	1
13	189988	GUIDE, priming piston; sst	1
14	112733	NUT, priming piston; carbon steel	1
15	190276	PISTON, priming; carbon steel	1
16*‡	184221	GLAND, intake valve, male; sst	1
17	184413	HOUSING, intake; ductile iron	1
18	184415	GUIDE, rod; sst	1
19	222920	HOUSING, outlet; ductile iron	1
20	184279	FITTING, outlet; 1-1/2" npt(m) x M42 x 20; carbon steel	1
21*‡	184185	GLAND, throat, female; sst	1
22*‡	109265	V-PACKING, throat; UHMWPE	3
23*‡	184235	GLAND, throat, male; sst	1
24*	109315	V-PACKING, throat; PTFE (222810 only)	2
24‡	109317	V-PACKING, throat; PTFE (246934 only)	2
25*‡	109213	O-RING; PTFE	1
32	109203	SCREW, cap, hex hd; 5/8-11 unc-2A x 12" (305 mm)	6
34	165702	BODY, bleeder valve; 3/8-18 npt x 1/2-20 unf-2b	1
35	190128	PLUG, valve; 1/2-20 unf-2a	1
39*†‡	184072	SEAL; Acetal	3
40*‡	109301	V-PACKING, intake valve; PTFE	2
41*‡	184171	GLAND, intake valve, female; sst	1
42*‡	109251	V-PACKING, intake valve; UHMWPE	2
43*‡	189724	SEAL; UHMWPE	1
44▲	184090	PLATE, warning (not shown)	1
45▲	184293	PLATE, warning (not shown)	1
46▲	172477	TAG, warning (not shown)	1
47▲	172479	TAG, warning (not shown)	1

\* These parts are included in Repair Kit 222860, which may be purchased separately.

† These parts are included in Intake Valve Repair Kit 222974, which may be purchased separately. (The kit includes one seal, item 39.)

▲ Replacement Danger and Warning labels, tags and cards are available at no cost.

‡ These parts are included in Repair Kit 234419, which may be purchased separately.

### PTFE Packing Conversion Kit 222861

Use to convert the pump to all PTFE throat and intake packings. Must be purchased separately. Includes instructions.

### Leather Packing Conversion Kit 222862

Use to convert the pump to leather throat and intake packings, with a PTFE backup. Must be purchased separately. Includes instructions.

### Ink Pump Conversion Kit 249032

Use to convert the pump from 222810 style to 246934 style.

# Technical Data

## (Model 222828 and 246935 Bulldog Pump)

Ratio .....	12:1 (Standard Bulldog Air Motor)
Maximum fluid working pressure .....	8.3 MPa, 83 bar (1200 psi)
Maximum air input pressure .....	0.7 MPa, 7 bar (100 psi)
Pump cycles per 3.8 liters (1 gal.) .....	8
Recommended pump speed for continuous operation .....	60 cycles per min
Maximum flow .....	28.5 liters/min (7.5 gpm) at 60 cycles/min
Air motor piston effective area .....	248 cm <sup>2</sup> (38.5 in. <sup>2</sup> )
Stroke length .....	120 mm (4.75 in.)
Displacement pump effective area .....	21 cm <sup>2</sup> (3.255 in. <sup>2</sup> )
Maximum pump operating temperature .....	65.5°C (150°F)
Air inlet size .....	3/4 npsm(f)
Fluid outlet size .....	1-1/2" npt(m)
Weight .....	approx. 65 kg (142 lb)
Displacement Pump Weight .....	approx. 37 kg (81 lb)
Wetted parts .....	Carbon Steel; Chrome, Zinc, and Electroless Nickel Plating; 304 and 17-4 PH Grades of Stainless Steel; E52100 Alloy Steel; Ductile Iron; Acetal; PTFE; Ultra-High Molecular Weight Polyethylene

**KEY:** Fluid Outlet Pressure – Black Curves  
Air Consumption – Gray Curves

**A** 0.7 MPa, 7 bar (100 psi) Air Pressure  
**B** 0.49 MPa, 4.9 bar (70 psi) Air Pressure  
**C** 0.28 MPa, 2.8 bar (40 psi) Air Pressure

**NOTE:** Recommended pump speed for continuous operation (to shaded area): 60 cpm

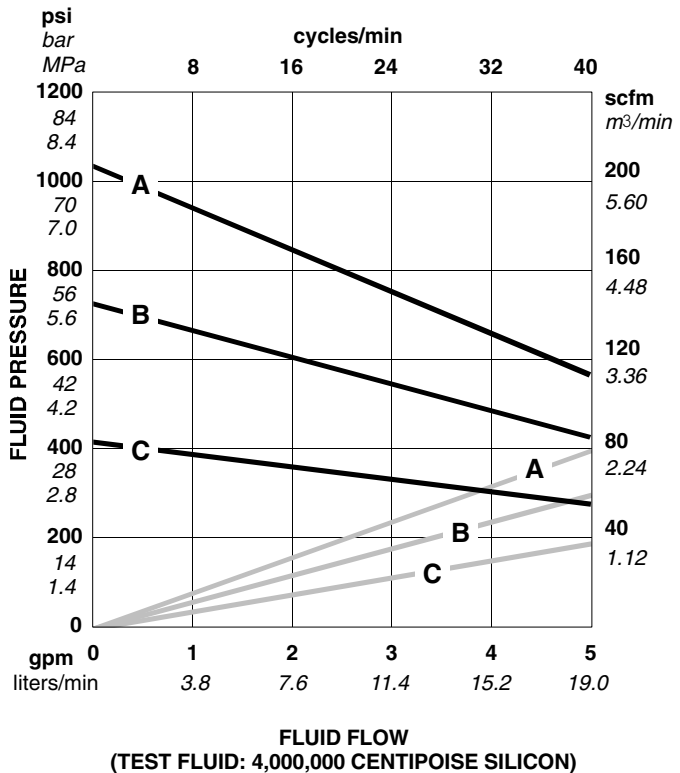
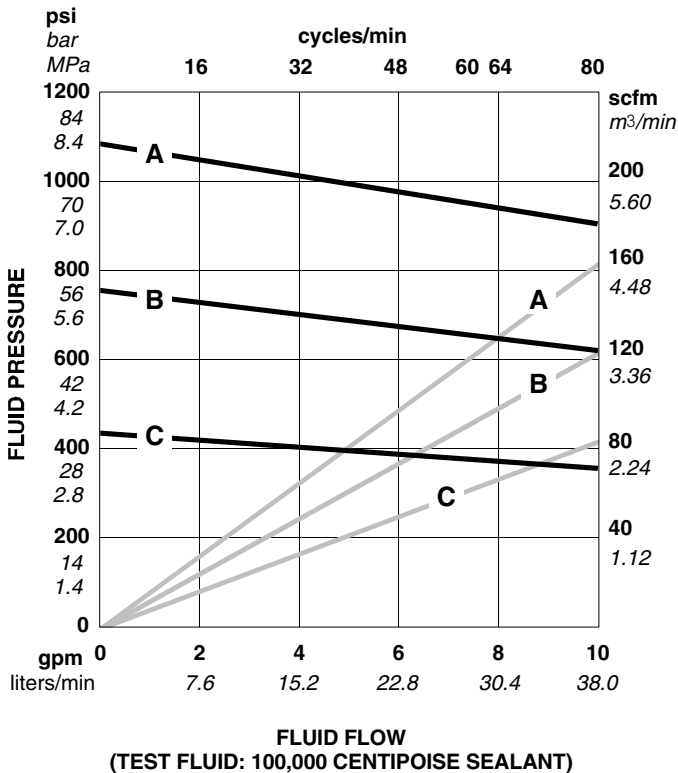

**To find Fluid Outlet Pressure** (MPa/bar/psi) at a specific fluid flow (lpm/gpm) and operating air pressure (MPa/bar/psi):

1. Locate desired flow along bottom of chart.
2. Follow vertical line up to intersection with selected fluid outlet pressure curve (black). Follow left to scale to read fluid outlet pressure.

**To find Pump Air Consumption** (m<sup>3</sup>/min or scfm) at a specific fluid flow (lpm/gpm) and air pressure (MPa/bar/psi):

1. Locate desired flow along bottom of chart.
2. Read vertical line up to intersection with selected air consumption curve (gray). Follow right to scale to read air consumption.

# Technical Data

## (Model 222829 Quiet Bulldog Pump)

Ratio .....	12:1 (Quiet Bulldog Air Motor)
Maximum fluid working pressure .....	8.3 MPa, 83 bar (1200 psi)
Maximum air input pressure .....	0.7 MPa, 7 bar (100 psi)
Pump cycles per 3.8 liters (1 gal.) .....	8
Recommended pump speed for continuous operation .....	60 cycles per min
Maximum flow .....	28.5 liters/min (7.5 gpm) at 60 cycles/min
Air motor piston effective area .....	248 cm <sup>2</sup> (38.5 in. <sup>2</sup> )
Stroke length .....	120 mm (4.75 in.)
Displacement pump effective area .....	21 cm <sup>2</sup> (3.255 in. <sup>2</sup> )
Maximum pump operating temperature .....	65.5°C (150°F)
Air inlet size .....	3/4 npsm(f)
Fluid outlet size .....	1-1/2" npt(m)
Weight .....	approx. 65 kg (142 lb)
Displacement Pump Weight .....	approx. 37 kg (81 lb)
Wetted parts .....	Carbon Steel; Chrome, Zinc, and Electroless Nickel Plating; 304 and 17-4 PH Grades of Stainless Steel; E52100 Alloy Steel; Ductile Iron; Acetal; PTFE; Ultra-High Molecular Weight Polyethylene

**KEY:** Fluid Outlet Pressure – Black Curves  
Air Consumption – Gray Curves

**A** 0.7 MPa, 7 bar (100 psi) Air Pressure  
**B** 0.49 MPa, 4.9 bar (70 psi) Air Pressure  
**C** 0.28 MPa, 2.8 bar (40 psi) Air Pressure

**NOTE:** Recommended pump speed for continuous operation (to shaded area): 60 cpm

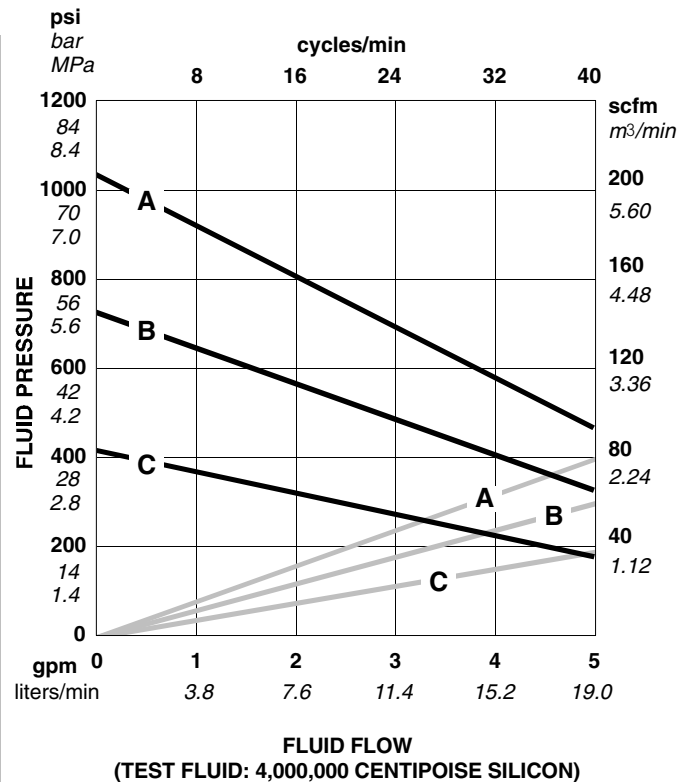
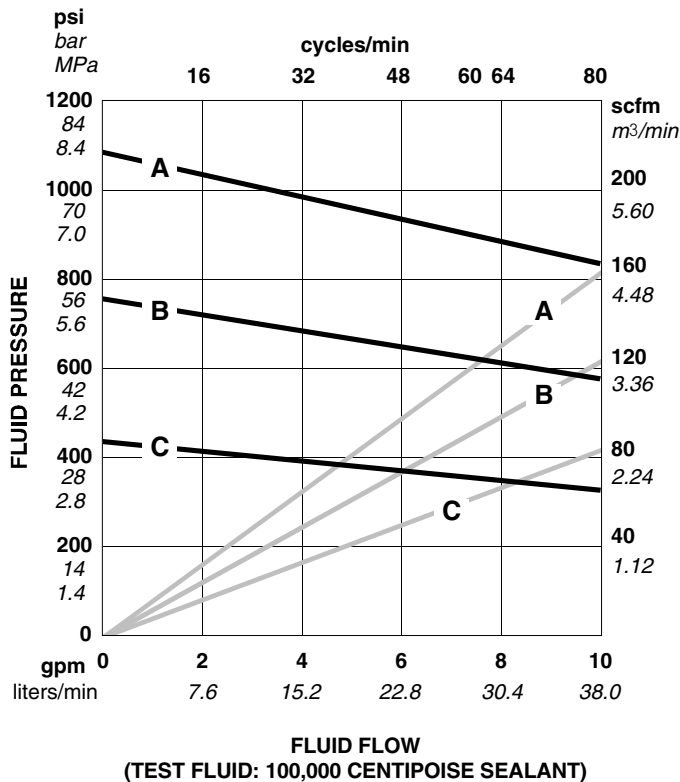

**To find Fluid Outlet Pressure** (MPa/bar/psi) at a specific fluid flow (lpm/gpm) and operating air pressure (MPa/bar/psi):

1. Locate desired flow along bottom of chart.
2. Follow vertical line up to intersection with selected fluid outlet pressure curve (black). Follow left to scale to read fluid outlet pressure.

**To find Pump Air Consumption** (m<sup>3</sup>/min or scfm) at a specific fluid flow (lpm/gpm) and air pressure (MPa/bar/psi):

1. Locate desired flow along bottom of chart.
2. Read vertical line up to intersection with selected air consumption curve (gray). Follow right to scale to read air consumption.

# Technical Data

## (Model 222835 and 246936 King Pump)

Ratio .....	24:1 (Standard King Air Motor)
Maximum fluid working pressure .....	16.6 MPa, 166 bar (2400 psi)
Maximum air input pressure .....	0.7 MPa, 7 bar (100 psi)
Pump cycles per 3.8 liters (1 gal.) .....	8
Recommended pump speed for continuous operation .....	50 cycles per min
Maximum flow .....	23.75 liters/min (6.25 gpm) at 50 cycles/min
Air motor piston effective area .....	506 cm <sup>2</sup> (78.5 in. <sup>2</sup> )
Stroke length .....	120 mm (4.75 in.)
Displacement pump effective area .....	21 cm <sup>2</sup> (3.255 in. <sup>2</sup> )
Maximum pump operating temperature .....	65.5°C (150°F)
Air inlet size .....	3/4 npsm(f)
Fluid outlet size .....	1-1/2" npt(m)
Weight .....	approx. 73 kg (160 lb)
Displacement Pump Weight .....	approx. 37 kg (81 lb)
Wetted parts .....	Carbon Steel; Chrome, Zinc, and Electroless Nickel Plating; 304 and 17-4 PH Grades of Stainless Steel; E52100 Alloy Steel; Ductile Iron; Acetal; PTFE; Ultra-High Molecular Weight Polyethylene

**KEY:** Fluid Outlet Pressure – Black Curves  
Air Consumption – Gray Curves

**A** 0.63 MPa, 6.3 bar (90 psi) Air Pressure  
**B** 0.49 MPa, 4.9 bar (70 psi) Air Pressure  
**C** 0.28 MPa, 2.8 bar (40 psi) Air Pressure

**NOTE:** Recommended pump speed for continuous operation (to shaded area): 50 cpm

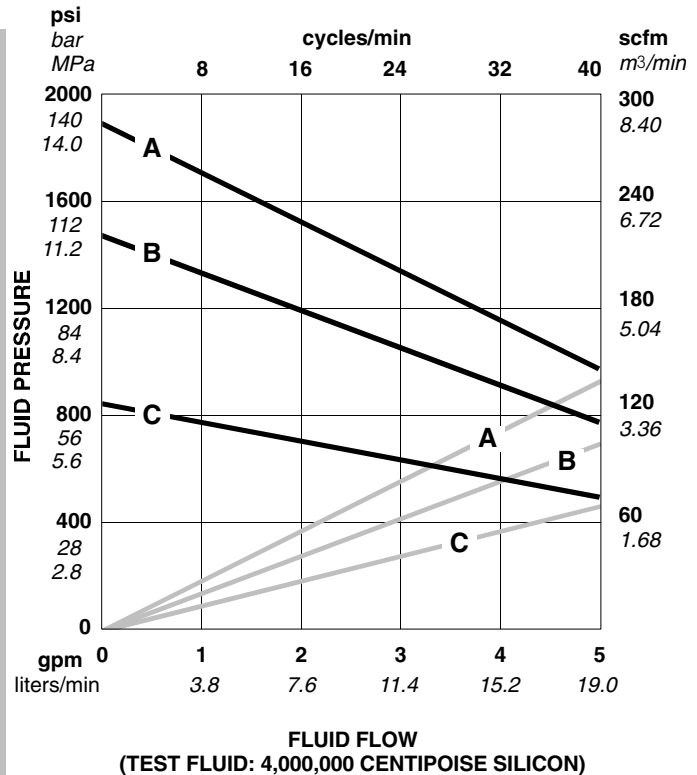
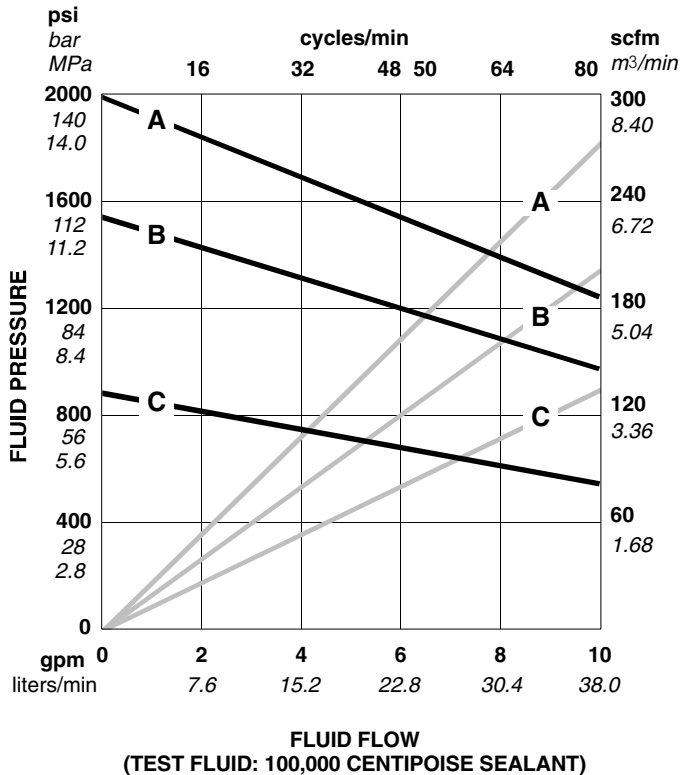

**To find Fluid Outlet Pressure (MPa/bar/psi) at a specific fluid flow (lpm/gpm) and operating air pressure (MPa/bar/psi):**

1. Locate desired flow along bottom of chart.
2. Follow vertical line up to intersection with selected fluid outlet pressure curve (black). Follow left to scale to read fluid outlet pressure.

**To find Pump Air Consumption (m<sup>3</sup>/min or scfm) at a specific fluid flow (lpm/gpm) and air pressure (MPa/bar/psi):**

1. Locate desired flow along bottom of chart.
2. Read vertical line up to intersection with selected air consumption curve (gray). Follow right to scale to read air consumption.



# Technical Data

## (Model 222901 Quiet King Pump)

Ratio .....	24:1 (Quiet King Air Motor)
Maximum fluid working pressure .....	16.6 MPa, 166 bar (2400 psi)
Maximum air input pressure .....	0.7 MPa, 7 bar (100 psi)
Pump cycles per 3.8 liters (1 gal.) .....	8
Recommended pump speed for continuous operation .....	50 cycles per min
Maximum flow .....	23.75 liters/min (7.5 gpm) at 50 cycles/min
Air motor piston effective area .....	506 cm <sup>2</sup> (78.5 in. <sup>2</sup> )
Stroke length .....	120 mm (4.75 in.)
Displacement pump effective area .....	21 cm <sup>2</sup> (3.255 in. <sup>2</sup> )
Maximum pump operating temperature .....	65.5°C (150°F)
Air inlet size .....	3/4 npsm(f)
Fluid outlet size .....	1-1/2" npt(m)
Weight .....	approx. 73 kg (160 lb)
Displacement Pump Weight .....	approx. 37 kg (81 lb)
Wetted parts .....	Carbon Steel; Chrome, Zinc, and Electroless Nickel Plating; 304 and 17-4 PH Grades of Stainless Steel; E52100 Alloy Steel; Ductile Iron; Acetal; PTFE; Ultra-High Molecular Weight Polyethylene

**KEY:** Fluid Outlet Pressure – Black Curves  
Air Consumption – Gray Curves

**A** 0.63 MPa, 6.3 bar (90 psi) Air Pressure  
**B** 0.49 MPa, 4.9 bar (70 psi) Air Pressure  
**C** 0.28 MPa, 2.8 bar (40 psi) Air Pressure

**NOTE:** Recommended pump speed for continuous operation (to shaded area): 50 cpm

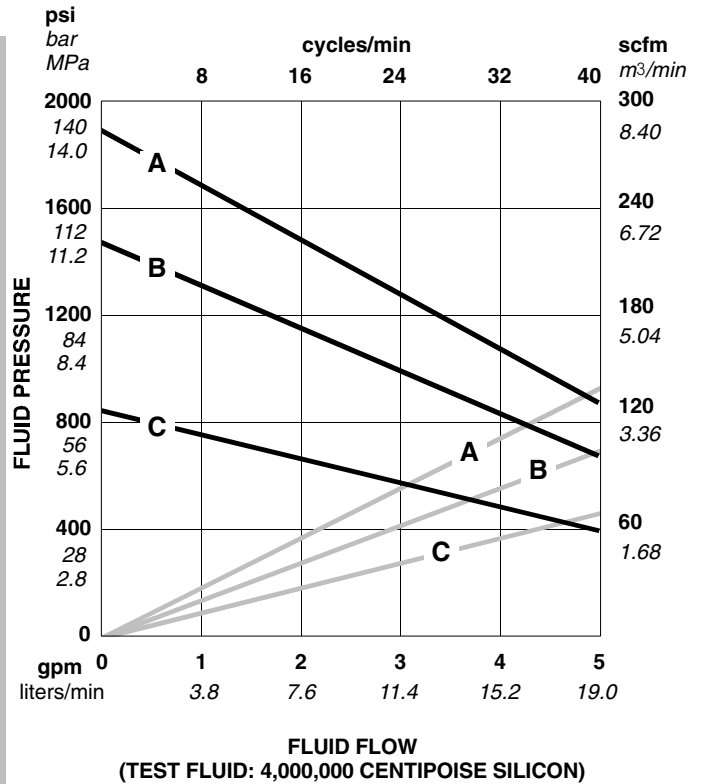
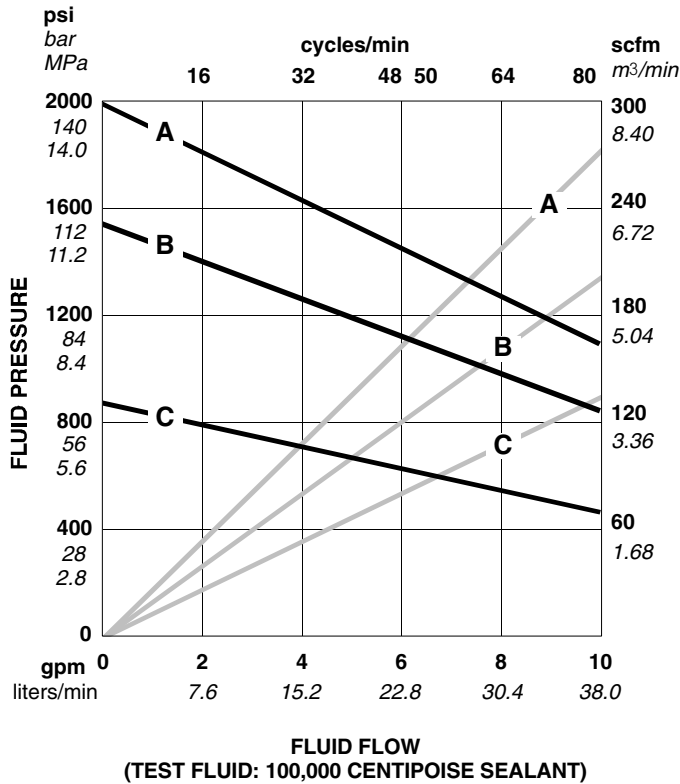

**To find Fluid Outlet Pressure** (MPa/bar/psi) at a specific fluid flow (lpm/gpm) and operating air pressure (MPa/bar/psi):

1. Locate desired flow along bottom of chart.
2. Follow vertical line up to intersection with selected fluid outlet pressure curve (black). Follow left to scale to read fluid outlet pressure.

**To find Pump Air Consumption** (m<sup>3</sup>/min or scfm) at a specific fluid flow (lpm/gpm) and air pressure (MPa/bar/psi):

1. Locate desired flow along bottom of chart.
2. Read vertical line up to intersection with selected air consumption curve (gray). Follow right to scale to read air consumption.

# Technical Data

## (Model 222940 Premier Pump)

Ratio .....	39:1 (Premier Air Motor)
Maximum fluid working pressure .....	26.9 MPa, 269 bar (3900 psi)
Maximum air input pressure .....	0.7 MPa, 7 bar (100 psi)
Pump cycles per 3.8 liters (1 gal.) .....	8
Recommended pump speed for continuous operation .....	50 cycles per min
Maximum flow .....	23.75 liters/min (6.25 gpm) at 50 cycles/min
Air motor piston effective area .....	800 cm <sup>2</sup> (38.5 in. <sup>2</sup> )
Stroke length .....	120 mm (4.75 in.)
Displacement pump effective area .....	21 cm <sup>2</sup> (3.255 in. <sup>2</sup> )
Maximum pump operating temperature .....	65.5°C (150°F)
Air inlet size .....	3/4 npsm(f)
Fluid outlet size .....	1-1/2" npt(m)
Weight .....	approx. 113 kg (248 lb)
Displacement Pump Weight .....	approx. 37 kg (81 lb)
Wetted parts .....	Carbon Steel; Chrome, Zinc, and Electroless Nickel Plating; 304 and 17-4 PH Grades of Stainless Steel; E52100 Alloy Steel; Ductile Iron; Acetal; PTFE; Ultra-High Molecular Weight Polyethylene

**KEY:** Fluid Outlet Pressure – Black Curves  
Air Consumption – Gray Curves

**NOTE:** Recommended pump speed for continuous operation (to shaded area): 50 cpm

**A** 0.7 MPa, 7 bar (100 psi) Air Pressure  
**B** 0.49 MPa, 4.9 bar (70 psi) Air Pressure  
**C** 0.28 MPa, 2.8 bar (40 psi) Air Pressure

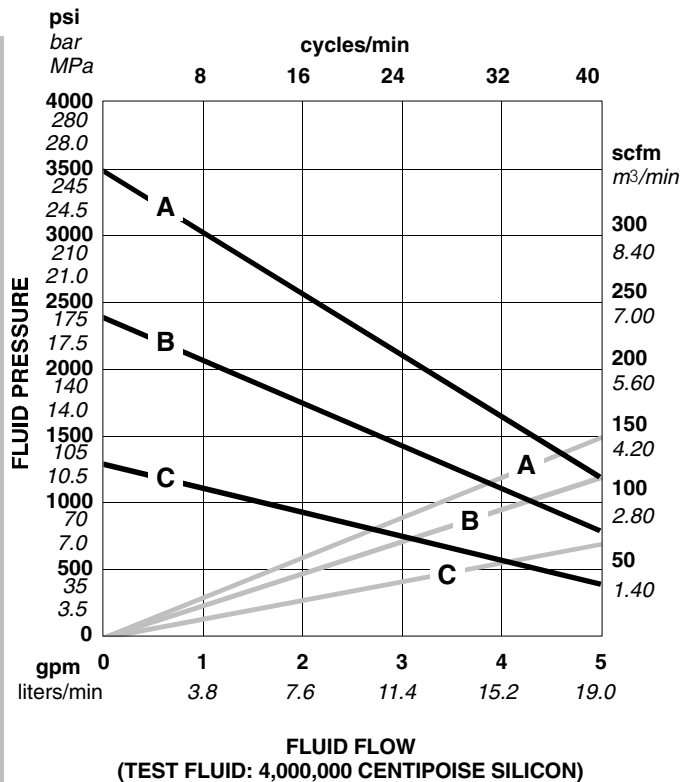
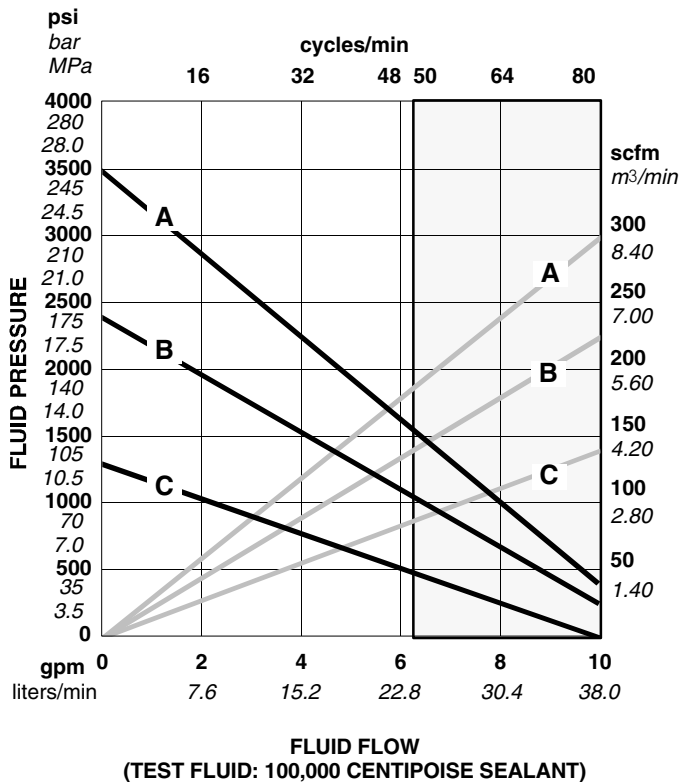

**To find Fluid Outlet Pressure (MPa/bar/psi) at a specific fluid flow (lpm/gpm) and operating air pressure (MPa/bar/psi):**

1. Locate desired flow along bottom of chart.
2. Follow vertical line up to intersection with selected fluid outlet pressure curve (black). Follow left to scale to read fluid outlet pressure.

**To find Pump Air Consumption (m<sup>3</sup>/min or scfm) at a specific fluid flow (lpm/gpm) and air pressure (MPa/bar/psi):**

1. Locate desired flow along bottom of chart.
2. Read vertical line up to intersection with selected air consumption curve (gray). Follow right to scale to read air consumption.

# Technical Data

## (Model 222902 and 246937 Viscount Pump)

Maximum fluid working pressure . . . . . 15.9 MPa, 159 bar (2300 psi)  
 Maximum hydraulic oil input pressure . . . . . 10.5 MPa, 105 bar (1500 psi)  
 Pump cycles per 3.8 liters (1 gal.) . . . . . 8  
 Recommended pump speed for continuous operation . . . . . 60 cycles per min  
 Maximum flow . . . . . 28.5 liters/min (7.5 gpm) at 60 cycles/min  
 Hydraulic motor piston effective area . . . . . 31.6 cm<sup>2</sup> (4.9 in.<sup>2</sup>)  
 Stroke length . . . . . 120 mm (4.75 in.)  
 Displacement pump effective area . . . . . 21 cm<sup>2</sup> (3.255 in.<sup>2</sup>)  
 Maximum pump operating temperature . . . . . 65.5°C (150°F)  
 Hydraulic oil inlet size . . . . . 3/4 npt(f)  
 Fluid outlet size . . . . . 1-1/2" npt(m)  
 Weight . . . . . approx. 89 kg (196 lb)  
 Displacement Pump Weight . . . . . approx. 37 kg (81 lb)  
 Wetted parts . . . . . Carbon Steel; Chrome, Zinc, and Electroless Nickel Plating;  
 304 and 17-4 PH Grades of Stainless Steel; E52100 Alloy Steel;  
 Ductile Iron; Acetal; PTFE; Ultra-High Molecular Weight Polyethylene

**KEY:** Fluid Outlet Pressure – Black Curves  
 Hydraulic Oil Consumption – Gray Curves

**A** 10.5 MPa, 105 bar (1500 psi) Hydraulic Oil Pressure  
**B** 7.4 MPa, 74 bar (1050 psi) Hydraulic Oil Pressure  
**C** 4.2 MPa, 42 bar (600 psi) Hydraulic Oil Pressure

**NOTE:** Recommended pump speed for continuous operation (to shaded area): 60 cpm

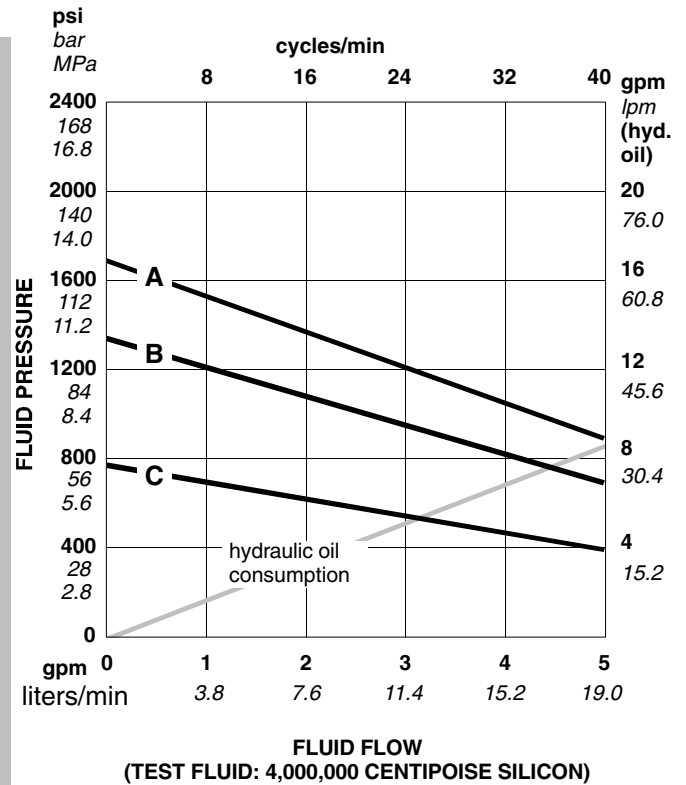
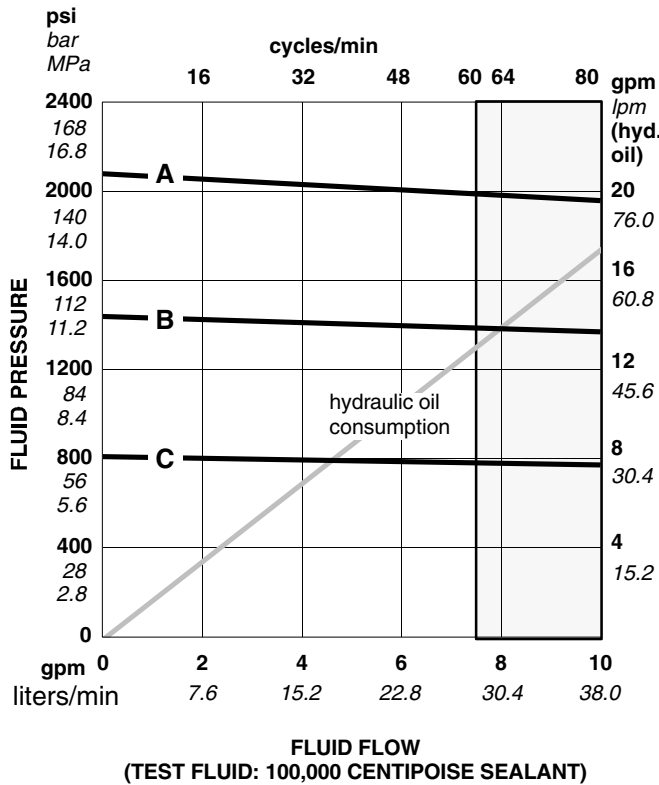

**To find Fluid Outlet Pressure (MPa/bar/psi) at a specific fluid flow (lpm/gpm) and operating hydraulic oil pressure (MPa/bar/psi):**

**To find Pump Hydraulic Oil Consumption (lpm or gpm) at a specific fluid flow (lpm/gpm) and hydraulic oil pressure (MPa/bar/psi):**

1. Locate desired flow along bottom of chart.
2. Follow vertical line up to intersection with selected fluid outlet pressure curve (black). Follow left to scale to read fluid outlet pressure.

1. Locate desired flow along bottom of chart.
2. Read vertical line up to intersection with oil consumption curve (gray). Follow right to scale to read oil consumption.

# Dimensions

Model 222835 Shown

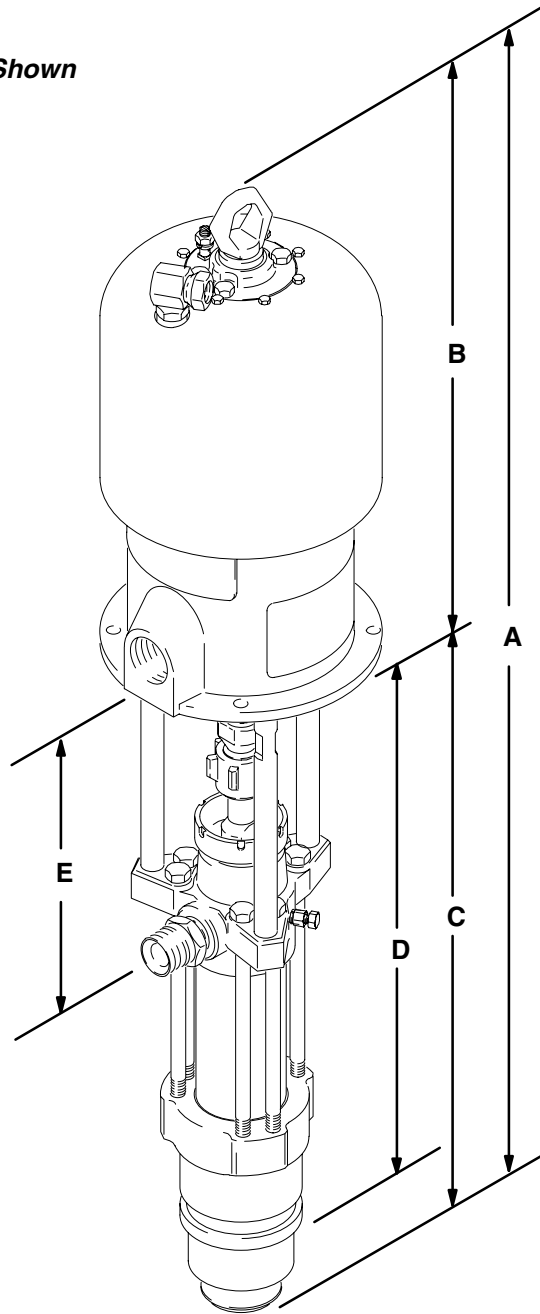

0913

Pump Model	A	B	C	D	E
<b>222828, 246935</b>	1333.6 mm (52.5 in.)	540.5 mm (21.28 in.)	793.1 mm (31.22 in.)	664.7 mm (26.17 in.)	256.8 mm (10.11 in.)
<b>222829</b>	1349.1 mm (53.11 in.)	556 mm (21.89 in.)	793.1 mm (31.22 in.)	664.7 mm (26.17 in.)	256.8 mm (10.11 in.)
<b>222835, 246936</b>	1376.1 mm (54.18 in.)	583 mm (22.95 in.)	793.1 mm (31.22 in.)	664.7 mm (26.17 in.)	256.8 mm (10.11 in.)
<b>222901</b>	1385.6 mm (54.55 in.)	592.5 mm (23.33 in.)	793.1 mm (31.22 in.)	664.7 mm (26.17 in.)	256.8 mm (10.11 in.)
<b>222940</b>	1530.7 mm (60.31 in.)	428.8 mm (16.89 in.)	1101.9 mm (43.41 in.)	969.5 mm (38.20 in.)	565.1 mm (22.26 in.)
<b>222902, 246937</b>	1415.3 mm (55.72 in.)	622.2 mm (24.5 in.)	793.1 mm (31.22 in.)	664.7 mm (26.17 in.)	256.8 mm (10.11 in.)

# Mounting Hole Layouts

## Bulldog, King, and Viscount Pumps

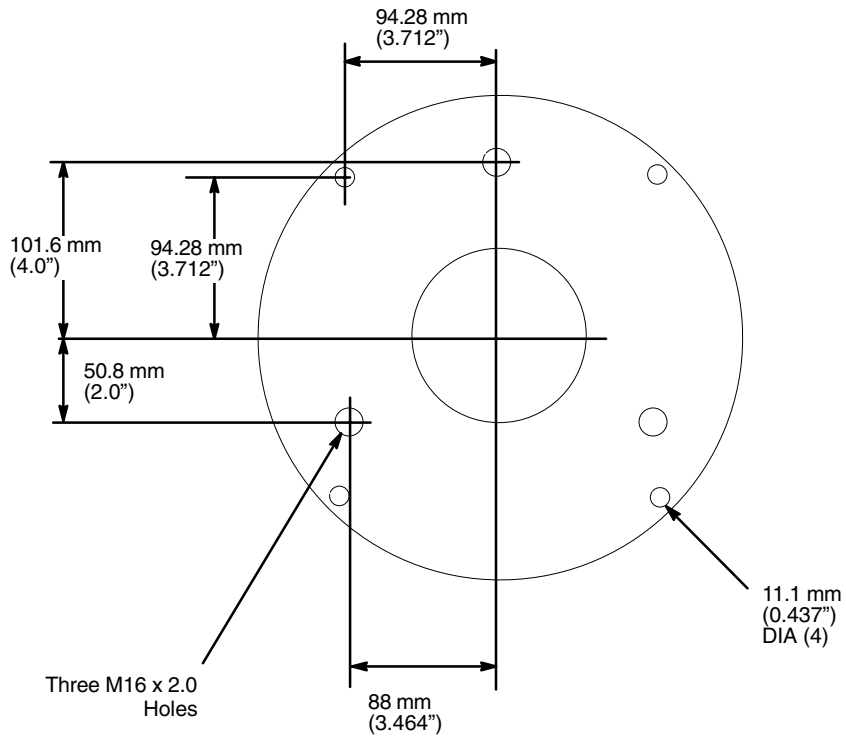

0653

## Premier Pumps

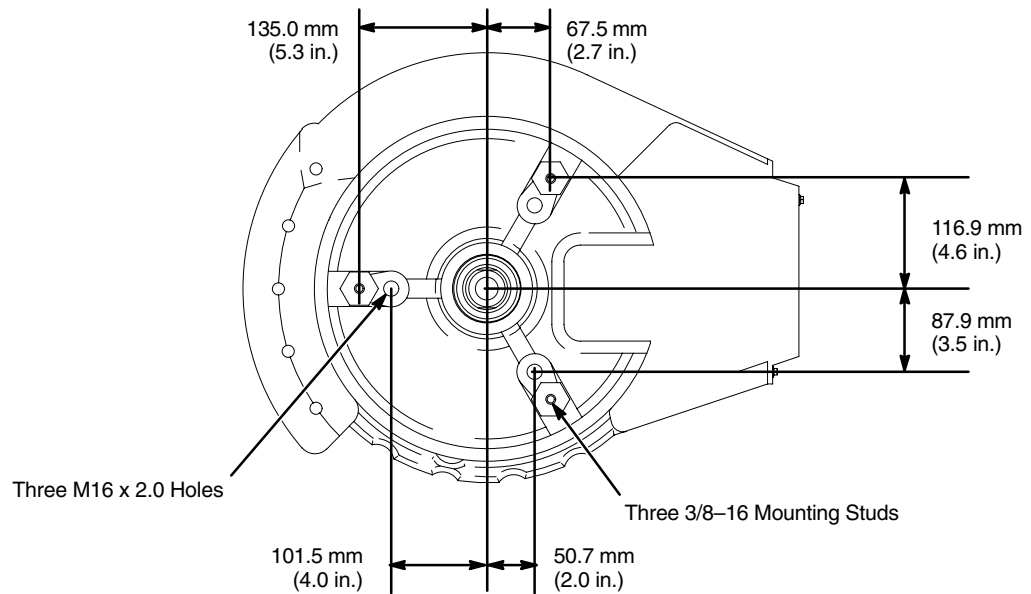

06555

# Graco Standard Warranty

Graco warrants all equipment manufactured by Graco and bearing its name to be free from defects in material and workmanship on the date of sale to the original purchaser for use. With the exception of any special, extended, or limited warranty published by Graco, Graco will, for a period of twelve months from the date of sale, repair or replace any part of the equipment determined by Graco to be defective. This warranty applies only when the equipment is installed, operated and maintained in accordance with Graco's written recommendations.

This warranty does not cover, and Graco shall not be liable for general wear and tear, or any malfunction, damage or wear caused by faulty installation, misapplication, abrasion, corrosion, inadequate or improper maintenance, negligence, accident, tampering, or substitution of non-Graco component parts. Nor shall Graco be liable for malfunction, damage or wear caused by the incompatibility of Graco equipment with structures, accessories, equipment or materials not supplied by Graco, or the improper design, manufacture, installation, operation or maintenance of structures, accessories, equipment or materials not supplied by Graco.

This warranty is conditioned upon the prepaid return of the equipment claimed to be defective to an authorized Graco distributor for verification of the claimed defect. If the claimed defect is verified, Graco will repair or replace free of charge any defective parts. The equipment will be returned to the original purchaser transportation prepaid. If inspection of the equipment does not disclose any defect in material or workmanship, repairs will be made at a reasonable charge, which charges may include the costs of parts, labor, and transportation.

**THIS WARRANTY IS EXCLUSIVE, AND IS IN LIEU OF ANY OTHER WARRANTIES, EXPRESS OR IMPLIED, INCLUDING BUT NOT LIMITED TO WARRANTY OF MERCHANTABILITY OR WARRANTY OF FITNESS FOR A PARTICULAR PURPOSE.**

Graco's sole obligation and buyer's sole remedy for any breach of warranty shall be as set forth above. The buyer agrees that no other remedy (including, but not limited to, incidental or consequential damages for lost profits, lost sales, injury to person or property, or any other incidental or consequential loss) shall be available. Any action for breach of warranty must be brought within two (2) years of the date of sale.

Graco makes no warranty, and disclaims all implied warranties of merchantability and fitness for a particular purpose in connection with accessories, equipment, materials or components sold but not manufactured by Graco. These items sold, but not manufactured by Graco (such as electric motors, switches, hose, etc.), are subject to the warranty, if any, of their manufacturer. Graco will provide purchaser with reasonable assistance in making any claim for breach of these warranties.

In no event will Graco be liable for indirect, incidental, special or consequential damages resulting from Graco supplying equipment hereunder, or the furnishing, performance, or use of any products or other goods sold hereto, whether due to a breach of contract, breach of warranty, the negligence of Graco, or otherwise.

## **FOR GRACO CANADA CUSTOMERS**

The parties acknowledge that they have required that the present document, as well as all documents, notices and legal proceedings entered into, given or instituted pursuant hereto or relating directly or indirectly hereto, be drawn up in English. Les parties reconnaissent avoir convenu que la rédaction du présente document sera en Anglais, ainsi que tous documents, avis et procédures judiciaires exécutés, donnés ou intentés à la suite de ou en rapport, directement ou indirectement, avec les procédures concernées.

## Graco Information

**TO PLACE AN ORDER**, contact your Graco distributor, or call one of the following numbers to identify the distributor closest to you:

**1-800-328-0211 Toll Free**

**612-623-6921**

**612-378-3505 Fax**

*All written and visual data contained in this document reflects the latest product information available at the time of publication.  
Graco reserves the right to make changes at any time without notice.*

MM 308149

**Graco Headquarters:** Minneapolis

**International Offices:** Belgium, China, Japan, Korea

**GRACO INC. P.O. BOX 1441 MINNEAPOLIS, MN 55440-1441**

**www.graco.com**

PRINTED IN U.S.A. 308149 05/1992, Revised 4/2006