

Instructions—Parts List



President 10:1 Ratio Air Spray System

306726T
ENG

Used for the application of non-abrasive fluids. For professional use only.

1800 psi (126 bar, 12.6 MPa) Maximum Working Pressure

Model 205627, Series H

Pail length, for 5 or 10 gallons,
with Relax-A-Valve.

Model 205628, Series H

Drum length for open-head drum,
with Relax-A-Valve



Important Safety Instructions

Read all warnings and instructions in this manual.
Save these instructions.

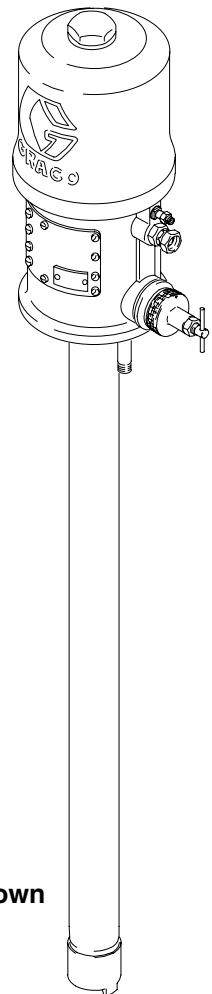

Model 205627 Shown



H003

Table of Contents

Warnings	2	Parts Lists and Drawings	
Installation	5	Model 205628	14
Operation	8	Model 205627	15
Maintenance	10	Relax-A-Valve	16
Troubleshooting	11	Technical Data	16
Displacement Pump Repair	12	Dimensions	17
Check Valve Adjustment	12	Warranty	20
Relax-A-Valve Repair	13	Graco Information	20

Symbols

Warning Symbol



This symbol alerts you to the possibility of serious injury or death if you do not follow the instructions.

Caution Symbol



This symbol alerts you to the possibility of damage to or destruction of equipment if you do not follow the instructions.

! WARNING



INSTRUCTIONS

EQUIPMENT MISUSE HAZARD

Equipment misuse can cause the equipment to rupture or malfunction and result in serious injury.

- This equipment is for professional use only.
- Read all instruction manuals, tags, and labels before operating the equipment.
- Use the equipment only for its intended purpose. If you are not sure, call your Graco distributor.
- Do not alter or modify this equipment.
- Check equipment daily. Repair or replace worn or damaged parts immediately.
- Do not exceed the maximum working pressure stated on the equipment or in the **Technical Data** for your equipment. Do not exceed the maximum working pressure of the lowest rated component in your system.
- Use fluids and solvents which are compatible with the equipment wetted parts. Refer to the **Technical Data** section of all equipment manuals. Read the fluid and solvent manufacturer's warnings.
- Handle hoses carefully. Do not pull on hoses to move equipment.
- Route hoses away from traffic areas, sharp edges, moving parts, and hot surfaces. Do not expose Graco hoses to temperatures above 66°C (150°F) or below -40°C (-40°F).
- Wear hearing protection when operating this equipment.
- Do not move or lift pressurized equipment.
- Comply with all applicable local, state, and national fire, electrical, and safety regulations.

⚠ WARNING



SKIN INJECTION HAZARD

Spray from the gun, leaks or ruptured components can inject fluid into your body and cause extremely serious injury, including the need for amputation. Fluid splashed in the eyes or on the skin can also cause serious injury.

- Fluid injected into the skin is a serious injury. The injury may look like just a cut, but it is a serious injury. **Get immediate surgical treatment.**
- Do not point the gun at anyone or at any part of the body.
- Do not put your hand or fingers over the spray tip.
- Do not stop or deflect leaks with your hand, body, glove or rag.
- Do not “blow back” fluid; this is not an air spray system.
- Always have the tip guard and the trigger guard on the gun when spraying.
- Check the gun diffuser operation weekly. Refer to the gun manual.
- Be sure the gun trigger safety operates before spraying.
- Lock the gun trigger safety when you stop spraying.
- Follow the **Pressure Relief Procedure** on page 8 if the spray tip clogs and before cleaning, checking or servicing the equipment.
- Tighten all fluid connections before operating the equipment.
- Check the hoses, tubes, and couplings daily. Replace worn, damaged, or loose parts immediately. Permanently coupled hoses cannot be repaired; replace the entire hose.



MOVING PARTS HAZARD

Moving parts can pinch or amputate your fingers.

- Keep clear of all moving parts when starting or operating the pump.
- Before checking or servicing the equipment, follow the **Pressure Relief Procedure** on page 8 to prevent the equipment from starting unexpectedly.

WARNING



FIRE AND EXPLOSION HAZARD

Improper grounding, poor ventilation, open flames or sparks can cause a hazardous condition and result in a fire or explosion and serious injury.



- Ground the equipment and the object being sprayed. Refer to **Grounding** on page 5.
- If there is any static sparking or you feel an electric shock while using this equipment, **stop spraying immediately**. Do not use the equipment until you identify and correct the problem.
- Provide fresh air ventilation to avoid the buildup of flammable fumes from solvents or the fluid being sprayed.
- Keep the spray area free of debris, including solvent, rags, and gasoline.
- Before operating this equipment, electrically disconnect all equipment in the spray area.
- Before operating this equipment, extinguish all open flames or pilot lights in the spray area.
- Do not smoke in the spray area.
- Do not turn on or off any light switch in the spray area while spraying or while operating if fumes are present.
- Do not operate a gasoline engine in the spray area.
- Never use 1,1,1-trichloroethane, methylene chloride, other halogenated hydrocarbon solvents, or fluids containing such solvents in this equipment. Such use could result in a serious chemical reaction, with the possibility of explosion, which could cause death, serious injury, and/or substantial property damage.

Consult your fluid suppliers to ensure that fluids being used are compatible with aluminum and zinc parts.



TOXIC FLUID HAZARD

Hazardous fluid or toxic fumes can cause serious injury or death if splashed in the eyes or on the skin, inhaled, or swallowed.

- Know the specific hazards of the fluid you are using.
- Store hazardous fluid in an approved container. Dispose of hazardous fluid according to all local, state and national guidelines.
- Always wear protective eyewear, gloves, clothing and respirator as recommended by the fluid and solvent manufacturer.

Installation

General Information

NOTE: Reference numbers and letters in parentheses refer to callouts in the Figs. and parts drawing.

NOTE: Always use Genuine Graco Parts and Accessories, available from your Graco distributor.

Grounding

⚠ WARNING

FIRE AND EXPLOSION HAZARD
Before operating the pump, ground the system as explained below. Also read the section **FIRE OR EXPLOSION HAZARD** on page 4.



1. *Pump:* use a ground wire and clamp as shown in Fig. 1. Loosen the grounding lug locknut (W) and washer (X). Insert one end of a 12 ga (1.5 mm²) minimum ground wire (Y) into the slot in lug (Z) and tighten the locknut securely. Connect the other end of the wire to a true earth ground. Order part number 222011 Grounding Clamp and Wire.
2. *Air and fluid hoses:* use only conductive hoses.
3. *Air compressor:* follow manufacturer's recommendations.

4. *Spray gun or dispensing valve:* ground through connection to a grounded fluid hose and pump.
5. *Fluid supply container:* follow your local code.
6. *Object being sprayed:* follow your local code.
7. *Solvent pails used when flushing:* follow your local code. Use only conductive metal pails, placed on a grounded surface. Do not place the pail on a nonconductive surface, such as paper or cardboard, which interrupts the grounding continuity.
8. *To maintain grounding continuity when flushing or relieving pressure,* hold a metal part of the spray gun firmly to the side of a grounded *metal* pail, then trigger the gun.

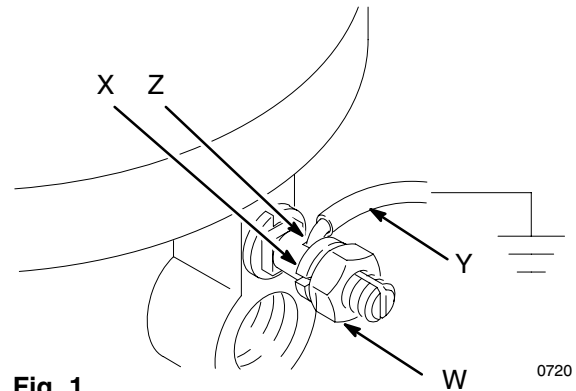

Fig. 1

Installation

NOTE: Reference numbers and letters in parentheses in the text refer to callouts in the figure illustrations and the parts drawing.

The Typical installation shown on page 7 is only a guide to electing and installing required and optional accessories. For assistance in designing a system to suit your needs, contact your Graco representative.

Mount the pump to suit the type of installation planned. The pump dimensions and mounting hole layout are shown on page 17.

Pail and Drum Length Pumps

Install the pump in the drum or pail, using a suitable cover, bung adapter, or mounting clamp. The pump must be 1/2 in. (13 mm) off the bottom of the pail or drum.

If the pump has a drain back tube, connect a drain hose to it and route the hose back to the supply container.

NOTE: In a closed-head drum, be sure to loosen the vent plug in the drum cover to prevent formation of a vacuum.

WARNING

Two accessories are required in your system: a bleed-type master air valve (A), if your pump does not have a Relax-A-Valve, and a fluid drain valve (H). These accessories help reduce the risk of serious injury including skin injection, splashing in the eyes, and injury from moving parts if you are adjusting or repairing the pump.

The bleed-type master air valve relieves air trapped between this valve and the pump after the air regulator is shut off. Trapped air can cause the pump to cycle unexpectedly. Locate the valve close to the pump.

The fluid drain valve assists in relieving fluid pressure in the displacement pump, hose, and gun; triggering the gun to relieve pressure may not be sufficient.

Pumps With Relax-A-Valve

An Evenflo air regulator may be installed on pumps having a Relax-A-Valve. This regulator prevents initial surging of non-atomized fluid when the gun is triggered. Air pressure in the pump is relieved automatically each time the gun trigger is released. When used with a Relax-A-Valve set in the automatic position, fluid pressure is relieved automatically also.

Installation

All Pumps

Install the air line accessories in the approximate order shown in the Typical Installation drawing. A pump runaway valve (B) senses when the pump is running too fast and shuts off the air supply to the motor. For automatic air motor lubrication, install an air line lubricator (D). (For manual lubrication, see Maintenance on page 10). Install the bleed-type master air valve (A) within easy reach of the pump. Install an air regulator (E) to control air to the motor and pump speed. An air line filter (C) removes harmful dirt and moisture from your compressed air supply.

Be sure that the air supply hose is properly grounded, and is at least 1.2 in. (13 mm) ID in order to supply an adequate volume of air to the motor.

On the fluid line, install a drain valve (H) close to the fluid outlet to assist in relieving fluid pressure (not required in pumps having a Relax-A-Valve). Connect a suitable grounded fluid hose and spray gun or dispensing valve to the pump's 3/4 in. npt outlet.

Typical Installation

KEY

- A Bleed-Type Master Air Valve
- B Pump Runaway Valve
- C Air Line Filter
- D Air Line Lubricator
- E Pump Air Regulator
- H Drain Valve
- J Pump Ground Wire
- K Grounded Fluid Hose
- L Grounded Air Hose
- 20, Relax-A-Valve
- 21 Drain Back Tube

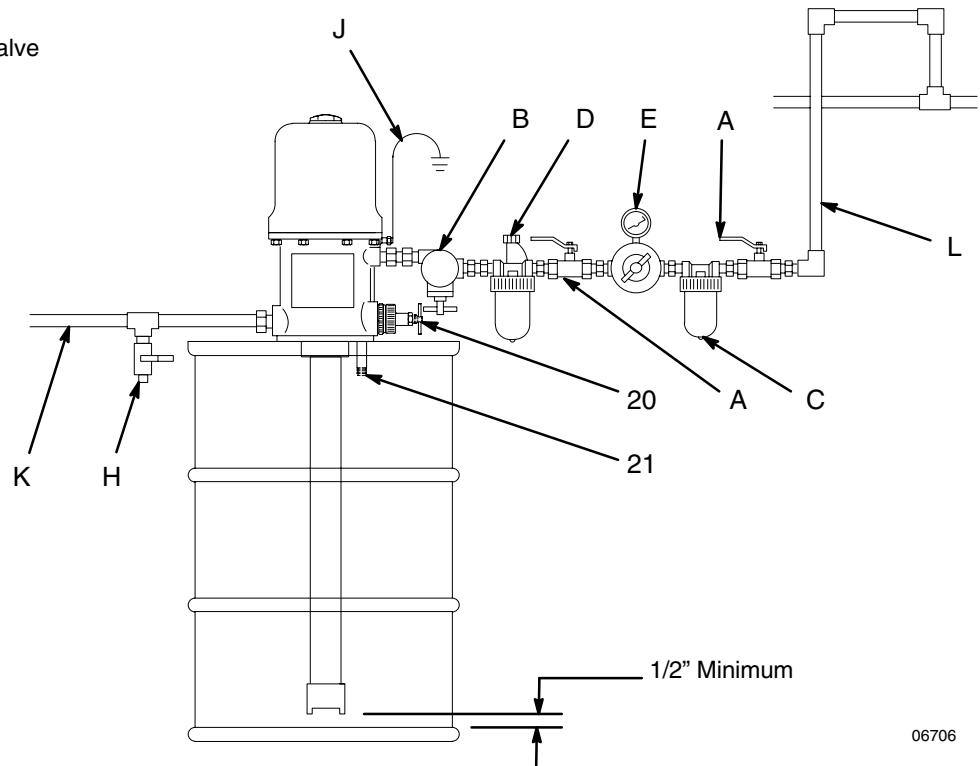

06706

Operation

Pressure Relief Procedure

With the Evenflo control, its bypass valve, and the pump Relax-A-Valve properly set, fluid pressure is relieved from the pump and hose each time you release the gun trigger. Always engage the gun trigger safety when you stop spraying. To relieve air pressure, close the Evenflo regulators and open the bleed-type master air valve.

WARNING



SKIN INJECTION HAZARD

If you suspect that the Evenflo system is not properly set, or that pressure is not fully relieved, the system pressure must

*be manually relieved to prevent the system from starting or spraying accidentally. Fluid under high pressure can be injected through the skin and cause serious injury. To reduce the risk of an injury from skin injection, splashing fluid, or moving parts, follow the **Pressure Relief Procedure** whenever you:*

- are instructed to relieve the pressure,
- stop spraying,
- check or service any of the system equipment,
- or install or clean the spray tips.

1. Engage the spray gun or dispensing valve safety latch.
2. Close the pump air regulator.
3. Close the master bleed-type air valve (required).
4. Disengage the gun or dispensing valve safety latch.
5. Hold a metal part of the gun/valve firmly to a grounded metal waste container and trigger to relieve fluid pressure.
6. Engage the safety latch again.
7. Open the pump drain valve (required in your system), having a container to catch the drainage.

NOTE: If your pump has a Relax-A-Valve set in the automatic position, step 7 is not necessary.

8. Leave the drain valve open until you are ready to spray again.

*If you suspect that the spray tip or hose is completely clogged, or that pressure has not been fully relieved after following the steps above, **very slowly** loosen the tip guard retaining nut or hose end coupling and relieve pressure gradually, then loosen completely. Now clear the tip or hose.*

WARNING

Never operate the pump with the air motor plate removed. Moving parts in the piston can pinch or amputate fingers.

Startup

WARNING

To reduce the risk of serious injury whenever you are instructed to relieve pressure, always follow the **Pressure Relief Procedure** on page 8.

The pump was tested in oil, and some oil was left in the pump to protect it from corrosion. If the oil will contaminate the fluid you are pumping, flush it out.

To start the pump, close the fluid drain valve (H). Open the bleed-type master air valves (A). Holding a metal part of the spray gun/dispensing valve firmly against the side of a grounded metal pail, hold the trigger open while slowly opening the air regulator (E). Run the pump slowly until all air is purged from the gun/valve. Release the trigger and engage the safety latch (if applicable).

Use the air regulator (E) to control fluid pressure and pump speed. Always use the lowest pressure necessary to get the desired results. Higher pressures cause premature pump wear and spray tip wear, and usually do not improve the spray pattern.

WARNING

To reduce the risk of overpressurizing your system, which could result in component rupture and cause serious injury, never exceed the maximum working pressure of the lowest rated component in your system. Lowering the air pressure to the motor will proportionately lower the fluid outlet pressure from the pump. Refer to the Technical Data on page 16 for the maximum air and fluid working pressure of this pump.

Operation

Using the Relax-A-Valve

If your pump has a Relax-A-Valve, it can be used to mix fluid by circulation (except in inductor-type follow plate installations), and it can be set to relieve fluid line pressure each time the pump air pressure is relieved.

To circulate fluid, open the Relax-A-Valve by loosening the locknut (119) and turning the T-handle screw (110) counterclockwise as far as possible. Start the pump and circulate the fluid as necessary. Stop the pump and close the Relax-A-Valve or set it in the automatic position. See Fig. 2.

To set the automatic position, loosen the locknut (119) and turn the T-handle screw (110) clockwise as far as possible. Back off the T-handle screw four turns and tighten the locknut. During normal operation, the fluid pressure is relieved automatically each time the air pressure to the pump is relieved.

NOTE: If your installation includes an Evenflo pressure regulator, air to the pump is automatically relieved each time you close the gun trigger, and the Relax--A-Valve, in turn, relieves fluid pressure.

Without an Evenflo, the bleed-type master air valve (A) should be used to relieve pump air pressure.

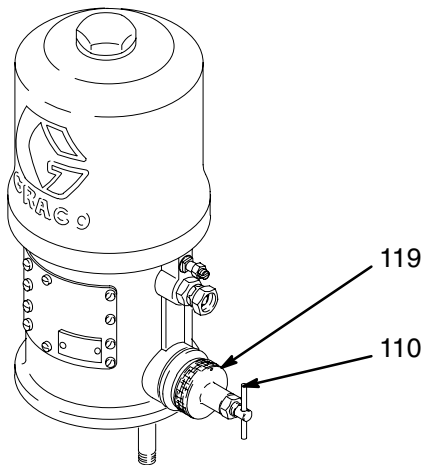

Fig. 2

06698

In a direct supply system, with adequate air pressure supplied to the motor, the pump starts when the gun or dispensing valve is opened, and stalls against pressure when it is closed.

If the pump accelerates quickly or is running too fast, stop it immediately. Check the fluid supply and refill it if necessary. Prime the pump to remove all air from the system, or flush the pump, **relieve the pressure**, but leave the system filled with mineral spirits or an oil-based solvent to protect the pump from corrosion.

NOTE: A pump runaway valve (B) can be installed on the air line to automatically shut off the pump if it starts to run too fast.

Shutdown and Care of the Pump

WARNING

To reduce the risk of serious injury whenever you are instructed to relieve pressure, always follow the **Pressure Relief Procedure** on page 8.

Relieve the pressure whenever you stop spraying.

Always stop the pump at the bottom of its stroke to prevent fluid from drying on the rod and damaging the throat packings.

If you are pumping fluid which dries, hardens, or sets up, flush the system with a compatible solvent as often as necessary to prevent a build up of dried fluid in the pump or hoses.

Maintenance

Lubrication

If your system includes an automatic air line lubricator, adjust the lubricator as instructed in the separate instruction manual.

For manual lubrication, each day, remove the air inlet hose and place 12 to 15 drops of high quality, light motor oil in the inlet. Reattach the hose and turn on the air to blow the oil into the motor.

Throat Packing Adjustment

⚠ WARNING

To reduce the risk of serious injury whenever you are instructed to relieve pressure, always follow the **Pressure Relief Procedure** on page 8.

Once a week, or after each 40 hours of operation, check the tightness of the throat packing nut. It should be tight enough to stop leakage, but no tighter.

To check, first **relieve the pressure**. Then, remove the identification plate (M) from the motor. Using a spanner wrench or a 0.22 in (5.6 mm) diameter rod, adjust the nut. Reinstall the identification plate before operating the pump. See Fig. 3.

Flushing

⚠ WARNING

To reduce the risk of serious injury whenever you are instructed to relieve pressure, always follow the **Pressure Relief Procedure** on page 8.

To reduce the risk of injection injury, static sparking, or splashing in the eyes or on the skin, **relieve the pressure**. Then, remove the spray tip (spray guns or spray valves only) before flushing. Hold a metal part of the gun/valve firmly to the side of a grounded metal pail and use the lowest possible fluid pressure during flushing.

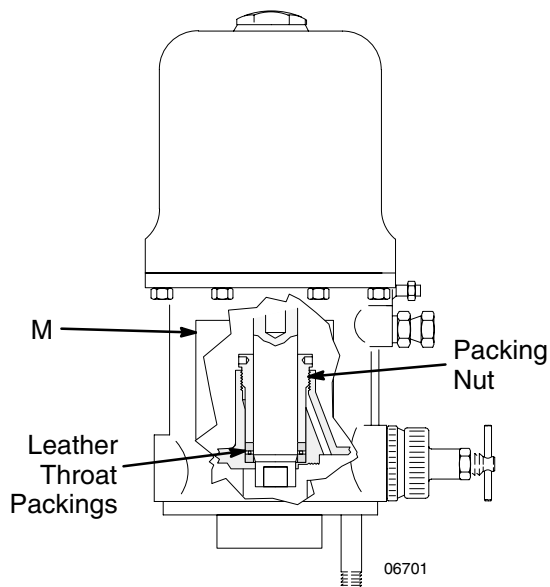

Fig. 3

Corrosion Protection

⚠ WARNING

To reduce the risk of serious injury whenever you are instructed to relieve pressure, always follow the **Pressure Relief Procedure** on page 8.

⚠ CAUTION

Water, or even moist air, can cause your pump to corrode. To help prevent corrosion, never leave the pump filled with water-based fluid or air. After normal flushing, flush the pump again with mineral spirits or oil-based solvent, and **relieve the pressure**. This leaves the mineral spirits in the pump.

Troubleshooting

WARNING

To reduce the risk of serious injury whenever you are instructed to relieve pressure, always follow the **Pressure Relief Procedure** on page 8.

Relieve the pressure before you check or service any system equipment.

NOTE: Check all possible problems and solutions before disassembling the pump.

WARNING

Never operate the pump with the air motor plate removed. Moving parts in the piston can pinch or amputate fingers.

Problem	Cause	Solution
Pump does not operate, or no fluid flow	Loose or broken pump parts	Disassemble, check, repair
	Restricted line or inadequate air supply	Clear, increase
	Exhausted fluid supply	Refill and prime
	Clogged fluid hoses	Clean, or replace
	Fluid intake or piston valves need adjustment	Adjust, see page 12
	Damaged air motor	Repair; see 306–982
Pump operates, but output is low	Insufficient air supply	Increase
	Exhausted fluid supply	Refill and prime
	Obstructed gun or dispensing valve	Clear
	Damaged fluid pump packings	Replace, see page 12
	Held open or worn piston or intake valve	Repair; see page 12
Erratic or accelerated operation	Exhausted fluid supply	Refill and prime
	Fluid intake or piston valve worn	Repair; see page 12

Service

Displacement Pump Repair

Before you start:

1. A packing repair kit, part no. 237498 is available. This kit includes two glands and eight packings for the motor as well as o-rings, packings, and washers for the displacement pump. For the best results use all the parts in the kit.
2. Clean all parts as you disassemble them, using a compatible solvent, and inspect for wear or damage. Replace parts as necessary.

Intake Valve (See Fig. 4)

WARNING

To reduce the risk of serious injury whenever you are instructed to relieve pressure, always follow the **Pressure Relief Procedure** on page 8.

1. **Relieve the pressure.**
2. Unscrew the intake valve housing (15).
3. Remove the ball stop pin (17). Inspect the ball (4) and seat (19a) for nicks or scratches.
4. Replace the ball and/or seat if it is damaged, as damaged parts do not seal properly and may cause poor pump performance.
5. If no further service is needed reassemble the intake valve. Be sure the ball stop pin (17) is reinstalled in the proper holes. See Check Valve Adjustment at right.

Piston

6. Unscrew the riser tube (9) from the pump base. Clean the tube and inspect it for wear by holding it up to a light at a slight angle. If you see wavy lines or scratches where the piston travels, replace the tube as it will not seal well with the new piston packings and the pump will perform poorly.
7. Loosen the locknut (2) and unscrew the piston (8) from the connecting rod (16).
8. Disassemble and clean all parts.

9. Reassemble the piston, using all the new parts from the kit and any other new parts needed. Oil the leather packings (10*) first. Then, reassemble the parts on the piston seat (7) in this order; backup washer (13), spreader (11), leather packing (10*), spacer (14) with a new o-ring (5) installed on it, another leather packing (10*), spreader (11) and backup washer (13*).

NOTE: To replace the throat packings, follow the steps given in your separate air motor manual, 306–392, supplied, before continuing with this procedure.

10. Apply sealant to the threads of the seat (7) and screw onto the piston body (8). Screw the piston onto the connecting rod (16) and adjust the ball travel as instructed in Check Valve Adjustment, below. Tighten the locknut (2).
11. Check the o-ring (6) in the pump base and replace it if necessary.
12. Lubricate the piston packings and the inner wall at the top of the riser tube (9). Wrap the packings with a guide collar made of 1/64 in. maximum thickness shim stock or metal sheeting. Using a turning motion, work the first leather packing into the riser tube. Remove the guide collar and push the riser tube up and screw it into the base. Torque the tube to 100–150 ft-lb (135–204 N•m).

Reassembly

1. Be sure the check valves are properly adjusted. See below.
2. Reinstall the intake valve.
3. Reconnect the pump's ground wire to a true earth ground.

Check Valve Adjustment

These pumps have adjustable fluid intake and piston ball checks, which are factory-set for medium viscosity fluids.

To change the piston ball travel, loosen the locknut (2). Turn the piston body (8) counterclockwise to increase and clockwise to decrease. Medium viscosity fluids should have a 3/16 in (5 mm) ball travel. See Fig. 5. Decreasing the ball travel minimizes surging at stroke changeover, but too short a ball travel restricts the flow and slows down the pump.

To change the intake valve ball travel, move the ball stop pin (17) to a higher or lower set of holes. Use the middle holes for medium viscosity fluids.

Service

Relax-A-Valve Repair

To remove an obstruction from the valve, loosen the locknut (119) and turn the T-handle completely counterclockwise. Turn on the pump and operate to flush out the obstruction. Stop the pump and **relieve the pressure**. Reset the Relax-A-Valve to the automatic position (See page 9).

If further repair is needed, relieve the pressure. Unscrew the valve housing (114) and seat (118) from the pump base. See Fig. 6.

1 Torque to 100–150 ft-lb (135–204 N•m)

2 Torque to 100–150 ft-lb (136–204 N•m)

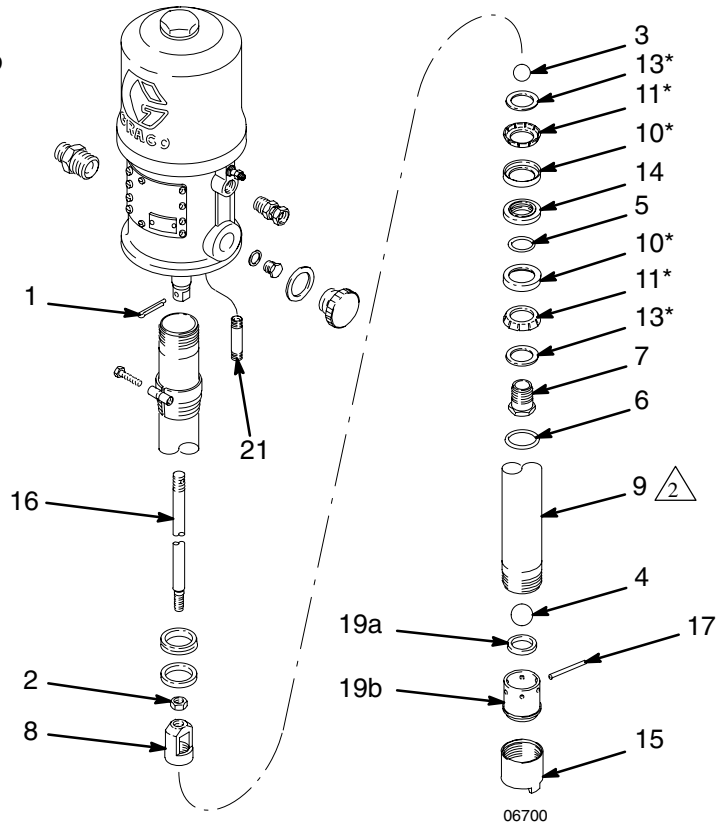

Fig. 4

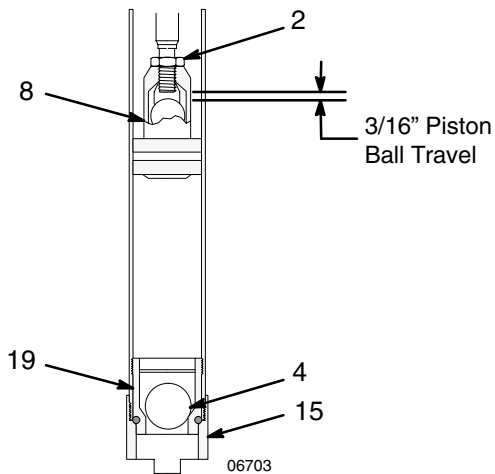

Fig. 5

Clean and inspect the seat and tip (117c) for wear or damage, replacing parts as necessary.

Check the piston travel. Unscrew the cap (115) from the housing. Check for a 1/4 in. (6 mm) clearance between the stop nut (112) and the jam nut (103). If adjustment is necessary, loosen the jam nut and turn the adjusting stem (111) in or out until you obtain the proper clearance. See Fig. 6. Tighten the jam nut.

Reassemble the Relax-A-Valve in the reverse order.

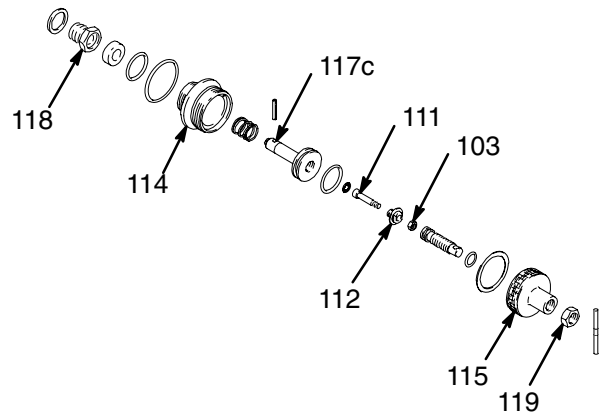

Fig. 6

Parts

Model 205628, Series H

Includes items 1–22

Ref. No.	Part No.	Description	Qty.
1	100103	PIN, cotter; 1/8" dia x 1-1/2"	1
2	100111	NUT, hex, jam; 1/2-20	1
3	100279	BALL, steel; 7/8" dia.	1
4	101178	BALL, steel; 1-1/4" dia.	1
5*	154662	O-RING; buna-N	1
6	156641	O-RING; buna-N	1
7	156989	SEAT, fluid piston valve	1
8	157184	BODY, fluid piston	1
9	158399	TUBE, riser; 32.75" (832 mm)	1
10*	158402	PACKING, cup; leather	2
11*	171590	WASHER, spreader	2
12	158586	BUSHING, pipe; 1" npt(m) x 3/4 npt(f)	1
13*	171594	WASHER, backup	2
14	158857	SPACER, fluid piston packing	1
15	159839	HOUSING, intake valve	1
16	164928	ROD, comm.; 22.325" (643 mm)	1
17	160726	STOP, ball, intake ball	1
18	205647	AIR MOTOR	1
19	204762	FOOT VALVE BODY & SEAT ASSY Includes items 19a and 19b	1
19a	161521	. SEAT, foot valve	1
19b	161820	. SEAT, ball	1
20	206280	RELAX-A-VALVE ASSEMBLY See parts list on page 16	1
21	100992	TUBE, drain back	1
22	158256	ADAPTER, air inlet; 1/2 npt(m) x 3/8 npsm(f) swivel	1

* Included in repair kit 237498

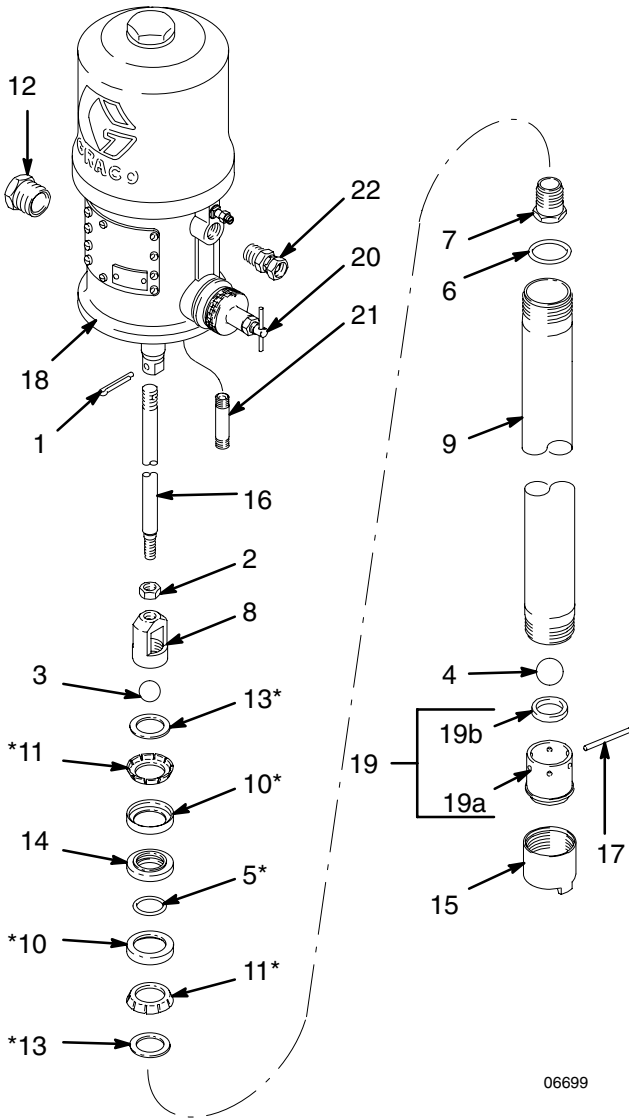

06699

Parts

Model 205627, Series H

Includes items 1–28

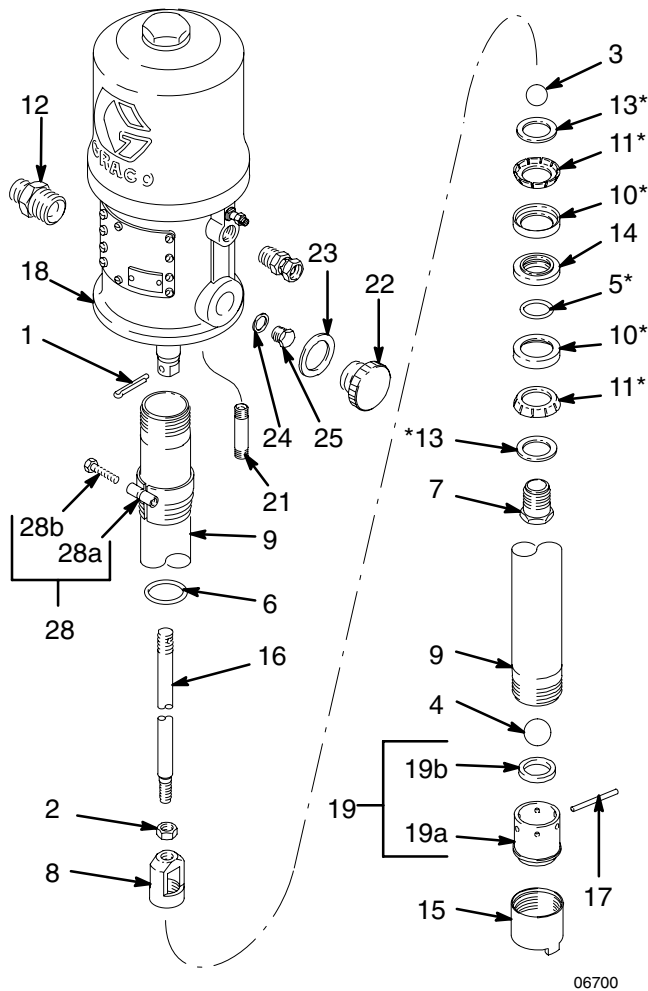

Ref. No.	Part No.	Description	Qty.
1	100103	PIN, cotter; 1/8" dia x 1-1/2"	1
2	100111	NUT, hex, jam; 1/2-20	1
3	100279	BALL, steel; 7/8" dia.	1
4	101178	BALL, steel; 1-1/4" dia.	1
5*	154662	O-RING; buna-N	1
6	156641	O-RING; buna-N	1
7	156989	SEAT, fluid piston valve	1
8	157184	BODY, fluid piston	1
9	159258	TUBE, riser; 17" (432 mm)	1
10*	158402	PACKING, cup; leather	2
11*	171590	WASHER, spreader	2
12	158555	NIPPLE, reducing; 1" npt(m) x 3/4 npt(f)	1
13*	171594	WASHER, backup	2
14	158857	SPACER, fluid piston packing	1
15	159839	HOUSING, intake valve	1
16	164927	ROD, comm.; 9.625" (244.5 mm)	1
17	160726	STOP, ball, intake ball	1
18	205647	AIR MOTOR	1
19	204762	See manual 306982 for parts FOOT VALVE BODY & SEAT ASSY Includes items 19a and 19b	1
19a	161521	. SEAT, foot valve	1
19b	161820	. SEAT, ball	1
20	206280	RELAX-A-VALVE ASSEMBLY See parts list on page 16	1
21	100992	TUBE, drain back	1
22	159445	PLUG, 1-3/8-12 NF2 thread	1
23	159446	GASKET, vellumoid	1
24	159890	GASKET, copper	1
25	157834	PLUG; 5/8-18 NF2 thread	1
28	222308	BUNG ADAPTER ASSEMBLY Includes items 28a and 28b	1
28a	104542	. SCREW, cap hex hd; M8 x 1.25	1
28b	210834	. ADAPTER, bung	1

* Included in repair kit 237498

Parts

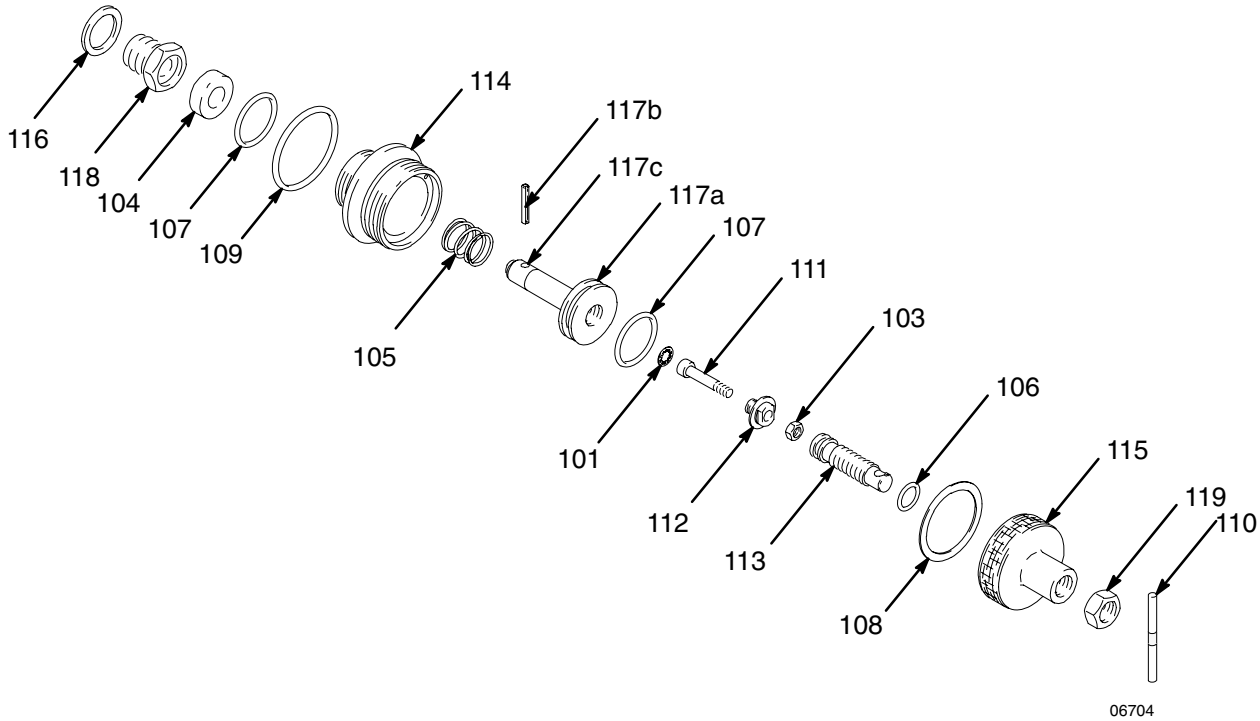

Ref. No. 20
Model 206280
 Includes items 101–119

Ref. No.	Part No.	Description	Qty.	Ref. No.	Part No.	Description	Qty.
				110	157131	HANDLE, valve tee	1
				111	158389	STEM, adjusting	1
				112	158390	NUT, stop	1
				113	158391	SCREW, adjusting	1
				114	158393	HOUSING, relax-a-valve	1
				115	158396	CAP, relax-a-valve	1
				116	159890	GASKET, copper	1
				117	203376	STEM ASSEMBLY	1
						Includes items 117a–117c	
101	100694	LOCKWASHER, internal, shkprf; 7/16"	1	117a	159050	STEM, valve	1
102	100992	TUBE, drain back	1	117b	101379	PIN, spring, straight	1
103	101345	NUT, hex, jam; 1/4–20	1	117c	203375	TIP, needle valve	1
104	101389	SEAL, leather	1	118	203374	SEAT ASSEMBLY	1
105	153996	SPRING, compression	1	119	100111	NUT, hex, jam; 1/2–20	2
106	154594	O-RING, Buna-N	1				
107	154662	O-RING	2				
108	155508	GASKET, vellumoid	1				
109	156633	O-RING, Buna-N	1				

Technical Data

Fluid pressure ratio	10:1
Air pressure operating range	40–180 psi (3–12 bar)
Maximum fluid working pressure	1800 psi (124 bar)
Maximum recommended pump speed	60 cycles/minute
Delivery (continuous duty)	3 gpm (12 liter/min)
Delivery (intermittent duty)	6 gpm (25 liter/min)
Cycles per gallon (liter)	20 (6)
Air motor effective diameter	4–1/4 in. (108 mm)
Pump stroke	4 in. (100 mm)
Air consumption	Approx. 13 CFM per gallon (6m ³ /hr/liter) of fluid at 100 psi (7 bar)
Wetted parts	Steel, Aluminum, Brass, Leather, Buna-N

Dimensions

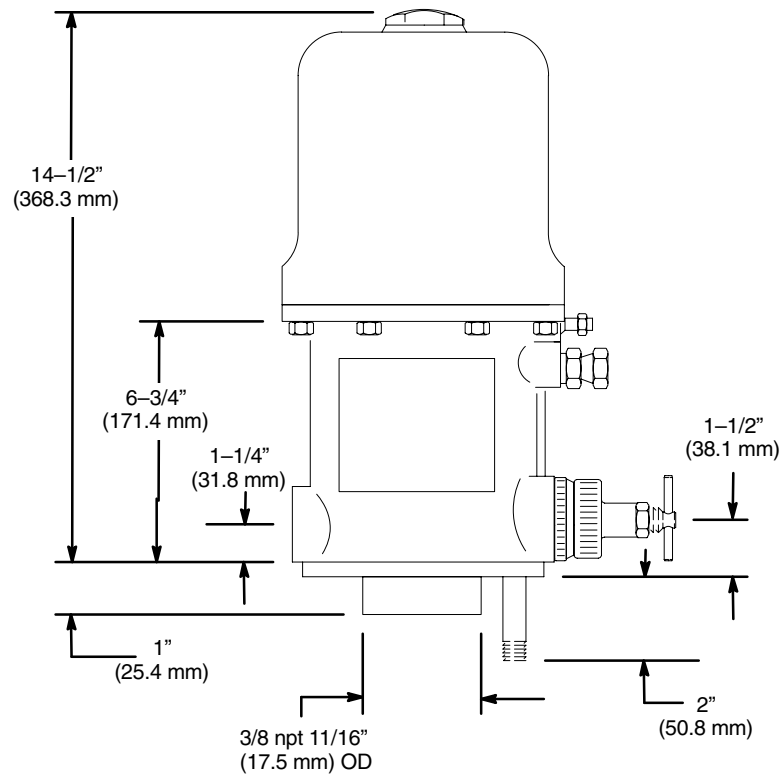

Bottom View

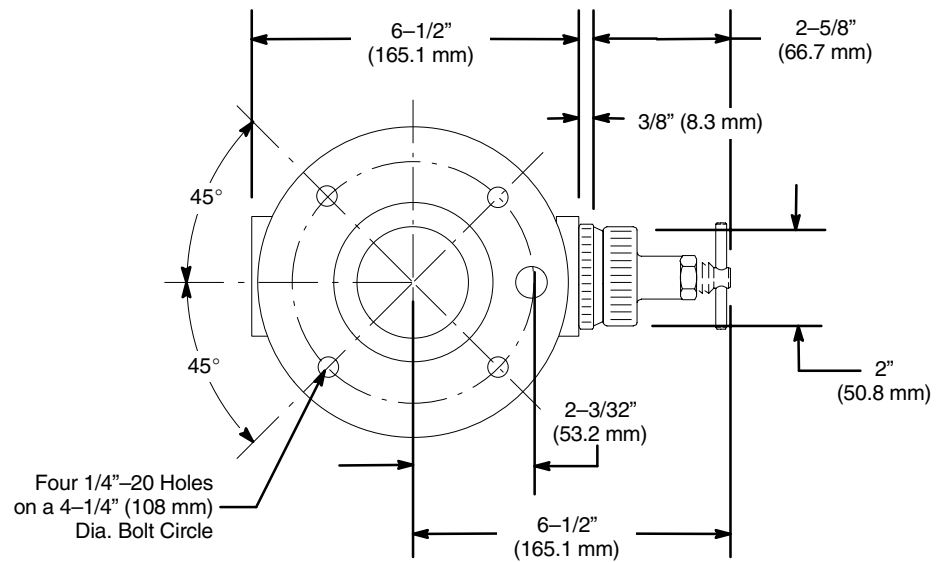

Dimensions

Model 205627, Series H
Weight: 29 lb (13 Kg)

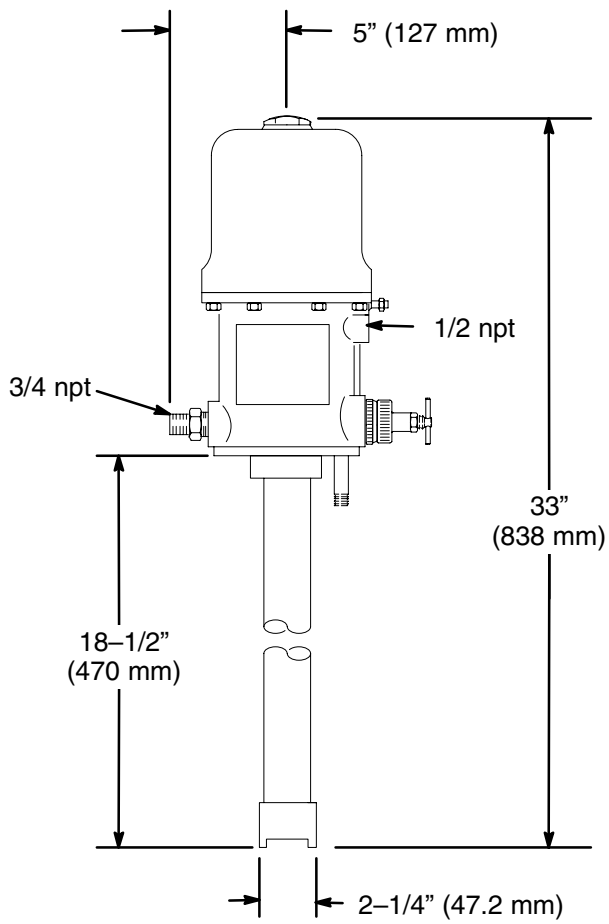

Model 205628, Series H
Weight: 40 lb (18 Kg)

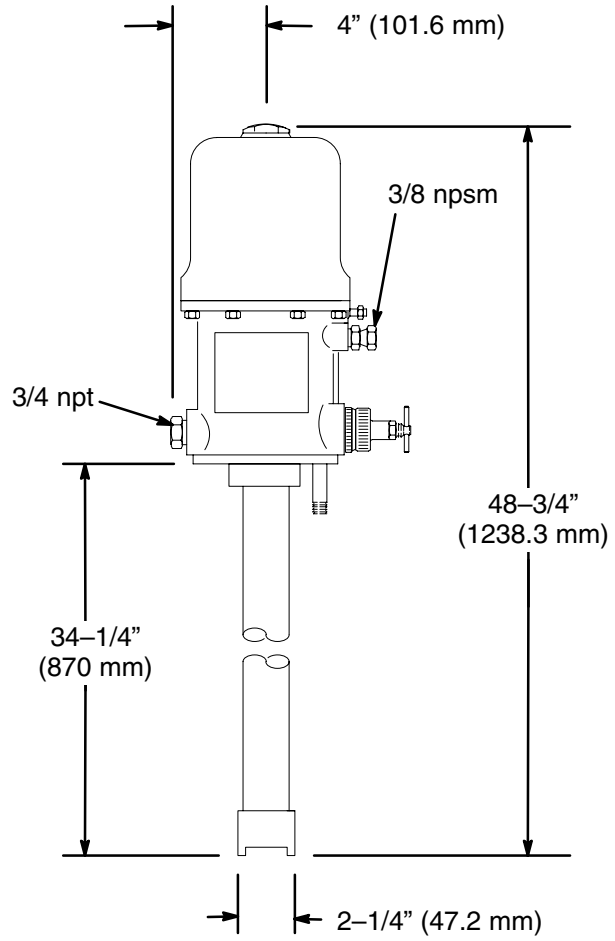

06713

Graco Standard Warranty

Graco warrants all equipment manufactured by Graco and bearing its name to be free from defects in material and workmanship on the date of sale to the original purchaser for use. With the exception of any special, extended, or limited warranty published by Graco, Graco will, for a period of twelve months from the date of sale, repair or replace any part of the equipment determined by Graco to be defective. This warranty applies only when the equipment is installed, operated and maintained in accordance with Graco's written recommendations.

This warranty does not cover, and Graco shall not be liable for general wear and tear, or any malfunction, damage or wear caused by faulty installation, misapplication, abrasion, corrosion, inadequate or improper maintenance, negligence, accident, tampering, or substitution of non-Graco component parts. Nor shall Graco be liable for malfunction, damage or wear caused by the incompatibility of Graco equipment with structures, accessories, equipment or materials not supplied by Graco, or the improper design, manufacture, installation, operation or maintenance of structures, accessories, equipment or materials not supplied by Graco.

This warranty is conditioned upon the prepaid return of the equipment claimed to be defective to an authorized Graco distributor for verification of the claimed defect. If the claimed defect is verified, Graco will repair or replace free of charge any defective parts. The equipment will be returned to the original purchaser transportation prepaid. If inspection of the equipment does not disclose any defect in material or workmanship, repairs will be made at a reasonable charge, which charges may include the costs of parts, labor, and transportation.

THIS WARRANTY IS EXCLUSIVE, AND IS IN LIEU OF ANY OTHER WARRANTIES, EXPRESS OR IMPLIED, INCLUDING BUT NOT LIMITED TO WARRANTY OF MERCHANTABILITY OR WARRANTY OF FITNESS FOR A PARTICULAR PURPOSE.

Graco's sole obligation and buyer's sole remedy for any breach of warranty shall be as set forth above. The buyer agrees that no other remedy (including, but not limited to, incidental or consequential damages for lost profits, lost sales, injury to person or property, or any other incidental or consequential loss) shall be available. Any action for breach of warranty must be brought within two (2) years of the date of sale.

Graco makes no warranty, and disclaims all implied warranties of merchantability and fitness for a particular purpose in connection with accessories, equipment, materials or components sold but not manufactured by Graco. These items sold, but not manufactured by Graco (such as electric motors, switches, hose, etc.), are subject to the warranty, if any, of their manufacturer. Graco will provide purchaser with reasonable assistance in making any claim for breach of these warranties.

In no event will Graco be liable for indirect, incidental, special or consequential damages resulting from Graco supplying equipment hereunder, or the furnishing, performance, or use of any products or other goods sold hereto, whether due to a breach of contract, breach of warranty, the negligence of Graco, or otherwise.

FOR GRACO CANADA CUSTOMERS

The parties acknowledge that they have required that the present document, as well as all documents, notices and legal proceedings entered into, given or instituted pursuant hereto or relating directly or indirectly hereto, be drawn up in English. Les parties reconnaissent avoir convenu que la rédaction du présente document sera en Anglais, ainsi que tous documents, avis et procédures judiciaires exécutés, donnés ou intentés à la suite de ou en rapport, directement ou indirectement, avec les procédures concernées.

Graco Information

For the latest information about Graco products, visit www.graco.com.

TO PLACE AN ORDER, contact your Graco distributor or call to identify the distributor closest to you:

Phone: 612-623-6921 or **Toll Free:** 1-800-328-0211 **Fax:** 612-378-3505

*All written and visual data contained in this document reflects the latest product information available at the time of publication.
Graco reserves the right to make changes at any time without notice.*

Original instructions. This manual contains English. MM 306726

Graco Headquarters: Minneapolis

International Offices: Belgium, China, Japan, Korea

GRACO INC. P.O. BOX 1441 MINNEAPOLIS, MN 55440-1441

Copyright 1996, Graco Inc. is registered to ISO 9001

www.graco.com

Revised 02/2011