

# High-Flo<sup>®</sup> Lowers

311690M

ENG

*Designed for low pressure, medium volume circulation of finishing materials.  
For professional use only.*



**Important Safety Instructions**

Read all warnings and instructions in your High-Flo Pump manual 311211. Save these instructions.

See page 2 for **Table of Contents** and page 2 for **List of Models** and Maximum Working Pressures.

Patent Pending

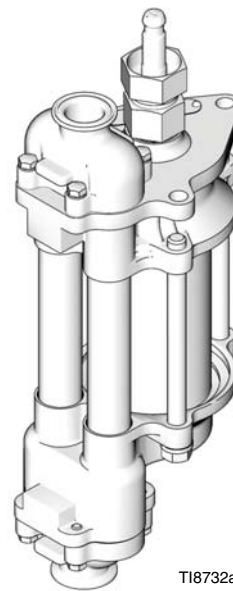

T18732a

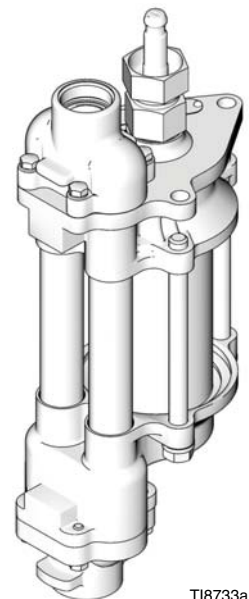

T18733a

# Contents

<b>Models</b> .....	<b>2</b>	<b>Lower Parts</b> .....	<b>14</b>
750cc Lowers .....	2	<b>Pump Seal Kits</b> .....	<b>20</b>
1000cc Lowers .....	2	Pump Seal Repair Kit 289548 .....	20
1500cc Lowers .....	3	Pump PTFE Seal Conversion Kit 289549 ..	20
2000cc Lowers .....	3	Pump Seal Repair Kit 277360 .....	20
<b>Warnings</b> .....	<b>4</b>	Pump PTFE Seal Conversion Kit 277361 ..	20
<b>Repair</b> .....	<b>6</b>	Pump Seal Repair Kit 277362 .....	20
Grounding .....	6	Pump PTFE Seal Conversion Kit 277363 ..	20
Pressure Relief Procedure .....	6	Pump Seal Repair Kit 277358 .....	20
Disconnect the Lower .....	7	Pump PTFE Seal Conversion Kit 277359 ..	20
Reconnect the Lower .....	7	<b>Throat Packing Kits</b> .....	<b>21</b>
Reassemble the Coupling Rod and Tie Rods to the Motor .....	8	Throat Packing Kit 239868 .....	21
Replace the Throat Packings Without Disconnecting the Lower .....	8	Throat Packing Kit 239872 .....	21
Repair Kits .....	9	Throat Packing Kit 239866 .....	21
Lower Disassembly .....	9	Throat Packing Kit 277356 .....	21
Clean and Inspect Parts .....	10	Throat Packing Kit 277357 .....	21
Lower Reassembly .....	10	Throat Packing Kit 24C405 .....	21
		<b>Graco Standard Warranty</b> .....	<b>22</b>
		<b>Graco Information</b> .....	<b>22</b>

## Models

### 750cc Lowers

Model No.	Series	Material	Seat	Size (cc)	Maximum Pump Working Pressure psi (MPa, bar)	Rod/Cylinder Material	Connection Style	Parts Page
289366	A	SST	Tungsten Carbide	750	500 (3.4, 34)	Chromex/Chrome	Inlet/Outlet 1-1/2 in. tri-clamp	15

### 1000cc Lowers

Model No.	Series	Material	Seat	Size (cc)	Maximum Pump Working Pressure psi (MPa, bar)	Rod/Cylinder Material	Connection Style	Parts Page
253033	A	SST	Tungsten Carbide	1000	400 (2.8, 28)	Chromex/Chrome	Inlet: 1-1/2 in. npt Outlet: 1 in. npt	16
24E783	A	SST	SST	1000	400 (2.8, 28)	Chromex/Chrome	Inlet: 1-1/2 in. npt Outlet: 1 in. npt	16
253061	A	CST	Tungsten Carbide	1000	400 (2.8, 28)	Chromex/Nitride	Inlet: 1-1/2 in. npt Outlet: 1 in. npt	16
253398	A	SST	Tungsten Carbide	1000	400 (2.8, 28)	Chromex/MaxLife	Inlet: 1-1/2 in. bspp Outlet: 1-1/4 in. bspp	16
253423	A	SST	Tungsten Carbide	1000	400 (2.8, 28)	Chromex/Chrome	Inlet: 1-1/2 in. bspp Outlet: 1-1/4 in. bspp	16
253520	A	SST	Tungsten Carbide	1000	400 (2.8, 28)	Chromex/Chrome	Inlet/Outlet 1-1/2 in. tri-clamp	16
253523	A	SST	Tungsten Carbide	1000	400 (2.8, 28)	Chromex/MaxLife	Inlet/Outlet 1-1/2 in. tri-clamp	16
253568	A	SST	Tungsten Carbide	1000	400 (2.8, 28)	Chromex/MaxLife	Inlet: 1-1/2 in. npt Outlet: 1 in. npt	16

## 1500cc Lowers

Model No.	Series	Material	Seat	Size (cc)	Maximum Pump Working Pressure psi (MPa, bar)	Rod/Cylinder Material	Connection Style	Parts Page
253034	A	SST	Tungsten Carbide	1500	460 (3.2, 32)	Chromex/Chrome	Inlet: 1-1/2 in. npt Outlet: 1 in. npt	17
24E784	A	SST	SST	1500	460 (3.2, 32)	Chromex/Chrome	Inlet: 1-1/2 in. npt Outlet: 1 in. npt	17
253062	A	CST	Tungsten Carbide	1500	460 (3.2, 32)	Chromex/Nitride	Inlet: 1-1/2 in. npt Outlet: 1 in. npt	17
253085	A	SST	Tungsten Carbide	1500	460 (3.2, 32)	Chromex/Chrome	Inlet: 1-1/2 in. bspp Outlet: 1-1/4 in. bspp	17
253397	A	SST	Tungsten Carbide	1500	460 (3.2, 32)	Chromex/MaxLife	Inlet: 1-1/2 in. bspp Outlet: 1-1/4 in. bspp	17
253521	A	SST	Tungsten Carbide	1500	460 (3.2, 32)	Chromex/Chrome	Inlet/Outlet 1-1/2 in. tri-clamp	17
253524	A	SST	Tungsten Carbide	1500	460 (3.2, 32)	Chromex/MaxLife	Inlet/Outlet 1-1/2 in. tri-clamp	17
253569	A	SST	Tungsten Carbide	1500	460 (3.2, 32)	Chromex/MaxLife	Inlet: 1-1/2 in. npt Outlet: 1 in. npt	17





## 2000cc Lowers





Model No.	Series	Material	Seat	Size (cc)	Maximum Pump Working Pressure psi (MPa, bar)	Rod/Cylinder Material	Connection Style	Parts Page
253035	A	SST	Tungsten Carbide	2000	460 (3.2, 32)	Chromex/Chrome	Inlet: 1-1/2 in. npt Outlet: 1 in. npt	18
24E785	A	SST	SST	2000	460 (3.2, 32)	Chromex/Chrome	Inlet: 1-1/2 in. npt Outlet: 1 in. npt	18
253063	A	SST	Tungsten Carbide	2000	460 (3.2, 32)	Chromex/Chrome	Inlet: 1-1/2 in. npt Outlet: 1 in. npt	18
253086	A	SST	Tungsten Carbide	2000	460 (3.2, 32)	Chromex/Chrome	Inlet: 1-1/2 in. bspp Outlet: 1-1/4 in. bspp	18
253396	A	SST	Tungsten Carbide	2000	460 (3.2, 32)	Chromex/MaxLife	Inlet: 1-1/2 in. bspp Outlet: 1-1/4 in. bspp	18
253522	A	SST	Tungsten Carbide	2000	460 (3.2, 32)	Chromex/Chrome	Inlet/Outlet 1-1/2 in. tri-clamp	18
253525	A	SST	Tungsten Carbide	2000	460 (3.2, 32)	Chromex/MaxLife	Inlet/Outlet 1-1/2 in. tri-clamp	18
253570	A	SST	Tungsten Carbide	2000	460 (3.2, 32)	Chromex/MaxLife	Inlet: 1-1/2 in. npt Outlet: 1 in. npt	18

**Wetted Parts:** Carbon Steel, Stainless Steel, Leather, PTFE,  
Ultra High Molecular Weight Polyethylene (UHMWPE),  
Tungsten Carbide

# Warnings

The following warnings are for the setup, use, grounding, maintenance, and repair of this equipment. The exclamation point symbol alerts you to a general warning and the hazard symbol refers to procedure-specific risk. Refer back to these warnings. Additional, product-specific warnings may be found throughout the body of this manual where applicable.

 <b>WARNING</b>	
	<p><b>FIRE AND EXPLOSION HAZARD</b></p> <p>Flammable fumes, such as solvent and paint fumes, in work area can ignite or explode. To help prevent fire and explosion:</p> <ul style="list-style-type: none"> <li>• Use equipment only in well ventilated area.</li> <li>• Eliminate all ignition sources; such as pilot lights, cigarettes, portable electric lamps, and plastic drop cloths (potential static arc).</li> <li>• Keep work area free of debris, including solvent, rags and gasoline.</li> <li>• Do not plug or unplug power cords, or turn power or light switches on or off when flammable fumes are present.</li> <li>• Ground all equipment in the work area. See <b>Grounding</b> instructions.</li> <li>• Use only grounded hoses.</li> <li>• Hold gun firmly to side of grounded pail when triggering into pail.</li> <li>• If there is static sparking or you feel a shock, <b>stop operation immediately</b>. Do not use equipment until you identify and correct the problem.</li> <li>• Keep a working fire extinguisher in the work area.</li> </ul>
	<p><b>PRESSURIZED EQUIPMENT HAZARD</b></p> <p>Fluid from the gun/dispense valve, leaks, or ruptured components can splash in the eyes or on skin and cause serious injury.</p> <ul style="list-style-type: none"> <li>• Follow <b>Pressure Relief Procedure</b> in this manual, when you stop spraying and before cleaning, checking, or servicing equipment.</li> <li>• Tighten all fluid connections before operating the equipment.</li> <li>• Check hoses, tubes, and couplings daily. Replace worn or damaged parts immediately.</li> </ul>
	<p><b>EQUIPMENT MISUSE HAZARD</b></p> <p>Misuse can cause death or serious injury.</p> <ul style="list-style-type: none"> <li>• Do not operate the unit when fatigued or under the influence of drugs or alcohol.</li> <li>• Do not exceed the maximum working pressure or temperature rating of the lowest rated system component. See <b>Technical Data</b> in all equipment manuals.</li> <li>• Use fluids and solvents that are compatible with equipment wetted parts. See <b>Technical Data</b> in all equipment manuals. Read fluid and solvent manufacturer's warnings. For complete information about your material, request MSDS forms from distributor or retailer.</li> <li>• Check equipment daily. Repair or replace worn or damaged parts immediately with genuine manufacturer's replacement parts only.</li> <li>• Do not alter or modify equipment.</li> <li>• Use equipment only for its intended purpose. Call your distributor for information.</li> <li>• Route hoses and cables away from traffic areas, sharp edges, moving parts, and hot surfaces.</li> <li>• Do not kink or over bend hoses or use hoses to pull equipment.</li> <li>• Keep children and animals away from work area.</li> <li>• Comply with all applicable safety regulations.</li> </ul>

 <b>WARNING</b>	
	<p><b>MOVING PARTS HAZARD</b></p> <p>Moving parts can pinch or amputate fingers and other body parts.</p> <ul style="list-style-type: none"> <li>• Keep clear of moving parts.</li> <li>• Do not operate equipment with protective guards or covers removed.</li> <li>• Pressurized equipment can start without warning. Before checking, moving, or servicing equipment, follow the <b>Pressure Relief Procedure</b> in this manual. Disconnect power or air supply.</li> </ul>
	<p><b>TOXIC FLUID OR FUMES HAZARD</b></p> <p>Toxic fluids or fumes can cause serious injury or death if splashed in the eyes or on skin, inhaled, or swallowed.</p> <ul style="list-style-type: none"> <li>• Read MSDS's to know the specific hazards of the fluids you are using.</li> <li>• Store hazardous fluid in approved containers, and dispose of it according to applicable guidelines.</li> <li>• Always wear impervious gloves when spraying or cleaning equipment.</li> </ul>
	<p><b>PERSONAL PROTECTIVE EQUIPMENT</b></p> <p>You must wear appropriate protective equipment when operating, servicing, or when in the operating area of the equipment to help protect you from serious injury, including eye injury, inhalation of toxic fumes, burns, and hearing loss. This equipment includes but is not limited to:</p> <ul style="list-style-type: none"> <li>• Protective eyewear</li> <li>• Clothing and respirator as recommended by the fluid and solvent manufacturer</li> <li>• Gloves</li> <li>• Hearing protection</li> </ul>

# Repair

- To service the pump assembly, see manual 311211.
- To service the air motor, see manual 311238.
- To service the hydraulic motor, see manual 308330.

## Grounding

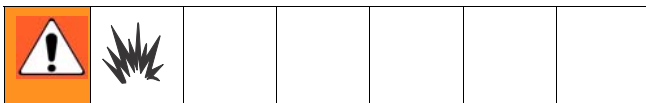

The equipment must be grounded. Grounding reduces the risk of static and electric shock by providing an escape wire for the electrical current due to static build up or in the event of a short circuit.

**Pump:** Use the ground screw (Z) and lockwasher on the motor to attach ground wire 244524 (Y). Tighten the screw securely. Connect the other end of the ground wire to a true earth ground. See FIG. 1.

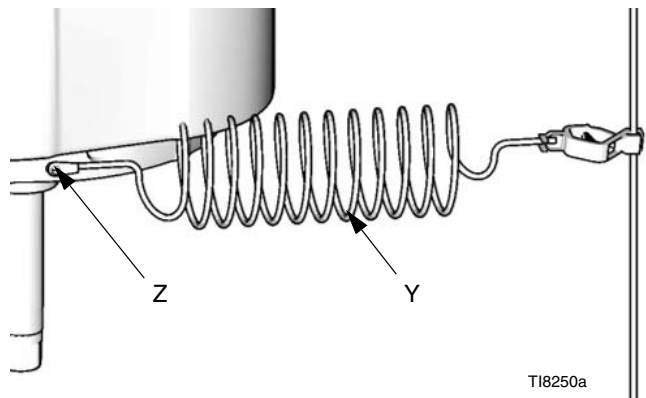

FIG. 1

**Air and fluid hoses:** use only electrically conductive hoses with a maximum of 500 ft. (150 m) combined hose length to ensure grounding continuity. Check the electrical resistance of hoses. If total resistance to ground exceeds 29 megohms, replace hose immediately.

**Air compressor:** follow manufacturer's recommendations.

**Hydraulic power supply:** follow manufacturer's recommendations.

**Surge tank:** use a ground wire and clamp.

**Spray gun:** ground through a connection to a properly grounded fluid hose and pump.

**Fluid supply container:** follow local code.

**Object being sprayed:** follow local code.

**Solvent pails used when flushing:** follow local code. Use only conductive metal pails, placed on a grounded surface. Do not place the pail on a nonconductive surface, such as paper or cardboard, which interrupts grounding continuity.

**To maintain grounding continuity when flushing or relieving pressure:** hold metal part of the spray gun firmly to the side of a grounded metal pail, then trigger the gun.

## Pressure Relief Procedure

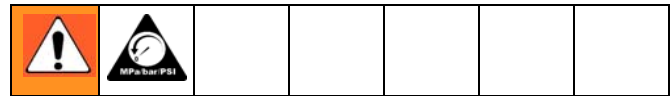

1. Engage trigger lock.
2. *Air-Powered Pumps only:* Close the bleed-type master air valve.  
  
*Hydraulic-Powered Pumps only:* Close the hydraulic supply line valve first, then the return line valve.
3. Disengage the trigger lock.
4. Hold a metal part of the gun firmly to a grounded metal pail. Trigger the gun to relieve pressure.
5. Engage the trigger lock.
6. Open all fluid drain valves in the system, having a waste container ready to catch drainage. Leave drain valve(s) open until you are ready to spray again.
7. If you suspect the spray tip or hose is clogged or that pressure has not been fully relieved after following the steps above, VERY SLOWLY loosen tip

guard retaining nut or hose end coupling to relieve pressure gradually, then loosen completely. Clear hose or tip obstruction.

### CAUTION

*Hydraulic-Powered Pumps only:* When shutting down the hydraulic system, always shut off the hydraulic supply line shutoff valve first, and then the return line shutoff valve to prevent overpressurizing the motor or its seals. When starting the hydraulic system, open the return line shutoff valve first.

## Disconnect the Lower

To disconnect the lower, follow the procedure on this page. See pages 8-11 for procedures to repair lower. To disconnect pump from an electric circulation assembly, EPXXXX, see manual 311594.

 In stand or wall-mounted installations, you do not have to remove the entire pump from its mounting.



1. Relieve the pressure, see Pressure Relief Procedure page 6.
2. Disconnect the hoses from the lower and plug the ends to prevent fluid contamination.
3. Loosen the coupling nut (K) and remove the collars (G). Remove the coupling nut from the piston rod (H). Unscrew the locknuts (B) from the tie rods (C). Pull the lower (D) off the motor (E). See FIG. 2 and FIG. 3.

## Reconnect the Lower

 If the coupling rod (F) and tie rods (C) have been disassembled from the motor, see Reassemble the Coupling Rod and Tie Rods to the Motor on page 8.

1. Assemble the coupling nut (K) to the piston rod (H).
2. Orient the lower (D) to the motor (E). Position the lower on the tie rods (C). Lubricate the threads of the tie rods. Screw the tie rod locknuts (B) onto the tie rods. Tighten the locknuts and torque to 50-55 ft-lb (68-75 N•m).

3. Insert the collars (G) into the coupling nut (K). Tighten the coupling nut onto the piston rod (H) and torque to 90-100 ft-lb (122-135 N•m).
4. Flush and test the pump before reinstalling it in the system. Connect hoses and flush the pump. While it is pressurized, check for smooth operation and leaks. Adjust or repair as necessary before reinstalling in the system. Reconnect the pump ground wire before operating.

### NXT Pump Shown

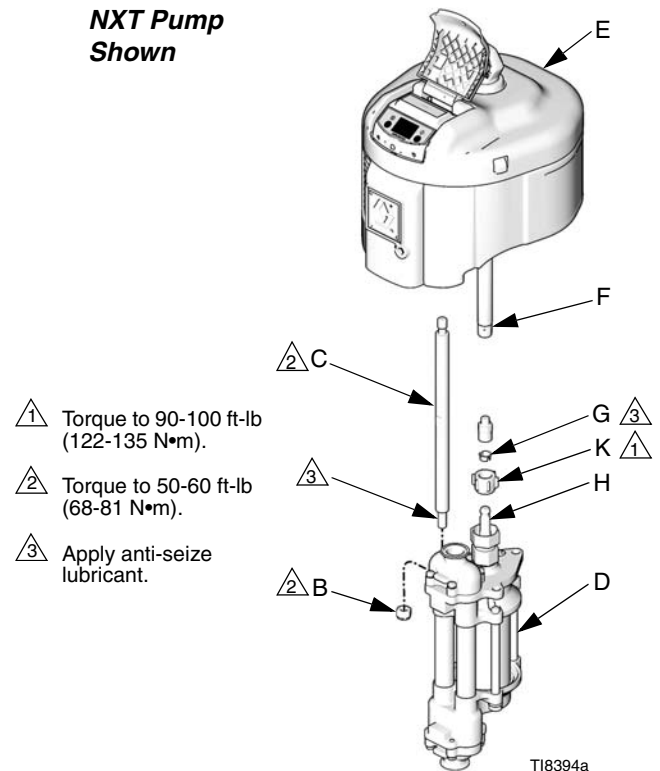

FIG. 2

**Viscount I+  
Pump Shown**

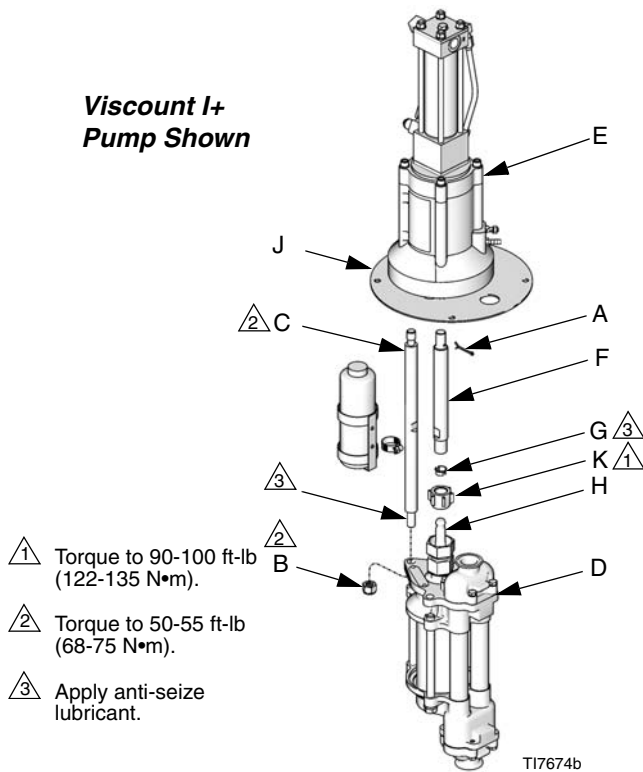

FIG. 3

## Reassemble the Coupling Rod and Tie Rods to the Motor

Use this procedure only if the coupling rod (F) and tie rods (C) have been disassembled from the motor, to ensure proper alignment of the motor shaft to the piston rod.

1. Loosen, but do not remove, the screws holding the adapter plate (J) to the motor (E) on Viscount I+ pumps. See FIG. 3.
2. Screw the tie rods (C) into the adapter plate (J) and torque to 50-55 ft-lb (68-75 N•m). On Viscount I+ pumps, the tie rods will engage threaded holes in the base of the motor.
3. Fill the cavity in the bottom of the motor shaft with grease. Screw the coupling rod (F) into the motor shaft until the pin holes align. On Viscount I+ pumps, install the pin (A) in the first hole from the end of the coupling.
4. Align the lower (D) with the tie rods (C) and loosely install the tie rod locknuts (B).

5. Insert the collars (G) and screw the coupling nut (K) onto the coupling rod (F) and torque to 90-100 ft-lb (122-135 N•m).
6. Torque the screws holding the adapter plate (J) to the motor (E) to 15-17 ft-lb (20-23 N•m). Torque the tie rod locknuts (B) to 50-55 ft-lb (68-75 N•m).

## Replace the Throat Packings Without Disconnecting the Lower

To replace the throat packings as part of a complete service of the lower, see page 9.

Throat packing kits are available. See page 21 to order. Parts supplied in the throat packing kit are marked with a symbol, for example (19†). For the best results, use all the parts in the kit.

1. Flush the pump, if possible.
2. Stop the pump at the middle of its stroke.
3. Shut off the air or hydraulic supply.
4. Unscrew the coupling nut (K) from the piston rod (H). Allow the nut and collars (G) to rest on the piston rod. See FIG. 2.
5. Cycle the pump slowly to the bottom of its stroke.

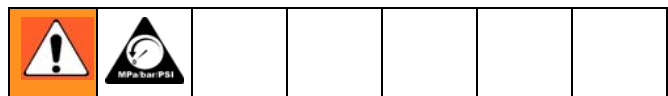

6. Relieve the pressure, see Pressure Relief Procedure, page 6.
  7. Lift the motor shaft and remove the coupling nut (K) and collars (G). See FIG. 2 and FIG. 3.
  8. Loosen the packing nut (21). See FIG. 8.
- Keep packing nut installed, but loose.
9. Loosen and remove the throat cartridge (35). Remove the PTFE o-ring (36). See FIG. 8.
  10. Remove the glands (19, 26) and packings (20, 25).



- Lubricate the throat packings and glands. Install one male gland (19†), then five v-packings with the lips facing down: one UHMWPE (20†), one leather (25†), UHMWPE, leather, UHMWPE. Install the female gland (26†). Install three v-packings with the lips facing up: UHMWPE, leather, UHMWPE. Install the other male gland (19†). Install the packing nut (21) finger-tight. See FIG. 8.

 Inspect the surface of the piston rod (17). If it is scratched, replace the piston rod.

- Install the o-ring (36†) on the throat cartridge (35). Apply lubricant to the throat cartridge threads then screw the cartridge into the upper pump housing (1). Torque the throat cartridge to 100 ft-lb (135 N•m).
- Tighten the packing nut (21) firmly and then turn the nut another 1/4 turn. If you have a torque wrench, tighten the packing nut to 30 ft-lb (40 N•m), then re-tighten to 15-20 ft-lb (20-27 N•m).
- Screw the coupling nut (K) and collars (G) onto the piston rod (H). Torque to 145-150 ft-lb (197-203 N•m). See FIG. 2.
- On Viscount I+ pumps, reinstall the pin (A). If necessary, reconnect the hydraulic supply and move the pump to the middle of its stroke. Install the pin in the first hole from the end of the coupling.

## Repair Kits

Pump seal kits are available for each pump size. Throat packing kits are also available. See page 19 to order.

Parts supplied in the pump seal kit are marked with one asterisk in the text and drawings, for example (2\*). Parts supplied in the throat packing kit are marked with a symbol, for example (19†). For the best results, use all the parts in the kit.

## Lower Disassembly

- Remove the pump from the motor as described on page 6. See also FIG. 7.
- Secure the inlet manifold (18) in a vise.
- Loosen, but do not remove, the packing nut (21) and cartridge (35). See FIG. 7.

- Remove the four capscrews (9) and washers (8) from around the outlet manifold (22).
- Remove the outlet manifold (22), balls (23), seats (24), and gaskets (7).
- Remove the three cylinder bolts (13) and lockwashers (14). Lift off the outlet housing (16), along with the fluid tubes (3), cylinder (1), and piston assembly (17, 10, 11, 12, 39).
- Remove the throat cartridge (35) and o-ring (36).
- Remove the glands (19, 26) and packings (20, 25).
- Remove the tubes (3) and cylinder (1) from the inlet housing (15). Pull the piston assembly out of the cylinder.
- Remove the inlet manifold (18) from the vise.
- Remove the four capscrews (9) and washers (8) from the inlet manifold (18). Use a flatblade screwdriver inserted between the inlet housing (15) and the inlet manifold (18) to separate them.

 One intake seat (6) includes a pressure relief valve (V). This seat must be located exactly where shown (the left side as viewed in FIG. 7). Use the text cast into the inlet housing as a guide.

- Remove the balls (5), intake seats (6 and 34), and gaskets (7).
- Inspect the pressure relief valve in the seat (6) to make sure it is not clogged. Press down on the valve's ball to see if the ball and the spring are free to move. See FIG. 4.

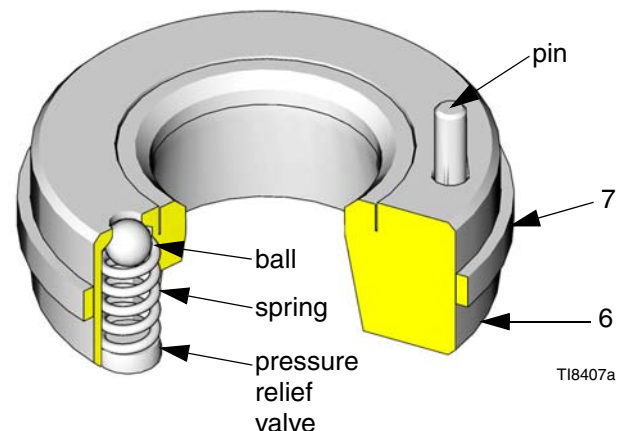

FIG. 4

**CAUTION**

If the pressure relief valve in the seat (6) is clogged or filled with material, soak the seat in a compatible solvent. Make sure all material residue is cleaned from the ball and seat area.

If the relief valve cannot be thoroughly cleaned so that the ball and spring are free to move, replace the seat (6).



- Place the flats of the piston nut (12) in a vise. Unscrew the rod (17) from the nut and spacer. Disassemble the piston (10) and remove the seal (11).

### Clean and Inspect Parts

Clean all parts in a compatible solvent. Inspect all parts for wear or damage. If you are using a repair kit, use all the new parts in the kit, discarding the old ones they replace. Replace any other parts as needed. Worn or damaged parts may cause the pump to perform poorly or cause premature wear of the new seals and packings.

### Lower Reassembly

- Place the halves of the piston (10) around the packing (11) and snap them together. See FIG. 8.
- Apply thread sealant (Loctite® 263 or 2760) to the piston rod (17) threads. Screw the rod through the piston, packing, and spacer and into the piston nut (12). Torque the nut to 95-100 ft-lb (129-135 N•m). Allow to cure for at least 12 hours before use.
- With the lower pump housing (11) turned upside down, install the balls (5) and the gaskets (7\*).

						
<b>COMPONENT RUPTURE HAZARD</b>						
The relief valve seat (6) must be installed at the fluid intake, as shown in FIG. 8. The relief valve reduces the risk of pump overpressurization. The seat cannot relieve pressure if installed on the other side of the inlet housing.						

- Install the relief valve intake seat (6) in the left side of the lower housing (11), as viewed in FIG. 8. (Text cast into the lower housing identifies the correct location for the relief valve seat.) The pin (P) on the seat must point up into the housing. The pin limits

the positioning of the seat, ensuring that the vent hole (V) is not blocked by part of the housing. See FIG. 5.

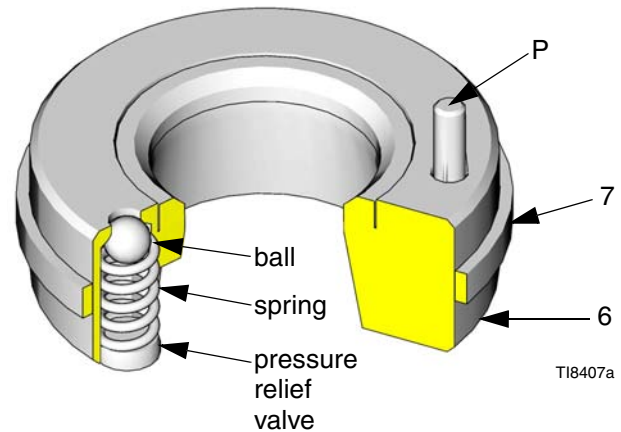



FIG. 5

- Install the inlet seat without a relief valve (34) in the right side of the inlet housing (15).

 The seats (6 and 34) are not reversible; the chamfered side must face the ball.

- Place the inlet manifold (18) on the inlet housing (15). Install the lockwashers (8) and capscrews (9). Torque to 25-30 ft-lb (34-40 N•m). See FIG. 8.
- Place the intake manifold (18) in a vise. Place one o-ring (2\*) in each side of the inlet housing (15), where the tubes (3) sit. Place o-rings (2\*) in the grooves at each end of the tubes. Place a gasket (4) in both the inlet and outlet housing (15 and 16). Position the tubes and cylinder (1) in the lower housing.

 It may be necessary to use a rubber mallet to set the fluid tubes (3) and cylinder (4) in place.

8. Lubricate the inside of the cylinder (4). Slide the piston assembly into the cylinder. Rotate the piston as shown in FIG. 6.

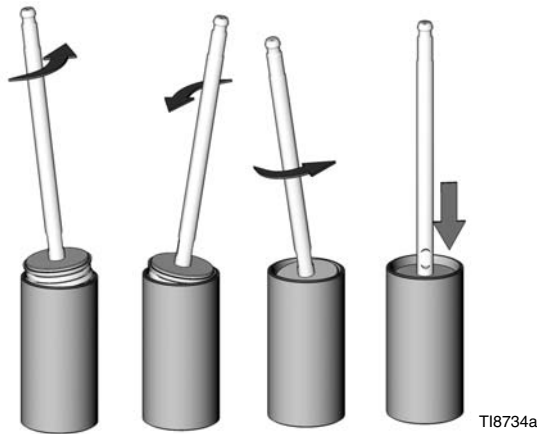

**FIG. 6**

washers (8) and screws (9), and torque to 25-30 ft-lb (34-40 N•m).

 Seat (24) is reversible.

15. Reconnect the lower to the motor. See page 7.

9. Install the o-ring (39†) on the throat cartridge (35), then screw the throat cartridge into the outlet housing (16).
10. Lubricate the throat packings and glands. Install one male gland (19†), then five v-packings with the lips facing down: one UHMWPE (20†), one leather (25†), UHMWPE, leather, UHMWPE. Install the female gland (26†). Install three v-packings with the lips facing up: UHMWPE, leather, UHMWPE. Install the other male gland (19†). Install the packing nut (21) finger-tight.
11. Install the outlet housing (16). It may not seat well on the tubes and cylinder. Install the bolts and lock-washers (14) from the inlet housing (15). As you tighten the bolts into the outlet housing (16), they will draw the housings firmly onto the tubes and cylinders. Tighten the bolts uniformly and torque to 25-30 ft-lb (34-40 N•m).
12. Apply lubricant to the throat cartridge threads and torque the cartridge (35) to 100 ft-lb (135 N•m).
13. Tighten the packing nut (21) firmly and then turn the nut another 1/4 turn. If you have a torque wrench, tighten the packing nut to 30 ft-lb (40 N•m), then re-tighten to 15-20 ft-lb (20-27 N•m).
14. Place a ball (23), seat (24) and gasket (7\*) in each side of the outlet manifold (22). Install the outlet manifold on the outlet housing (16). Install the lock-

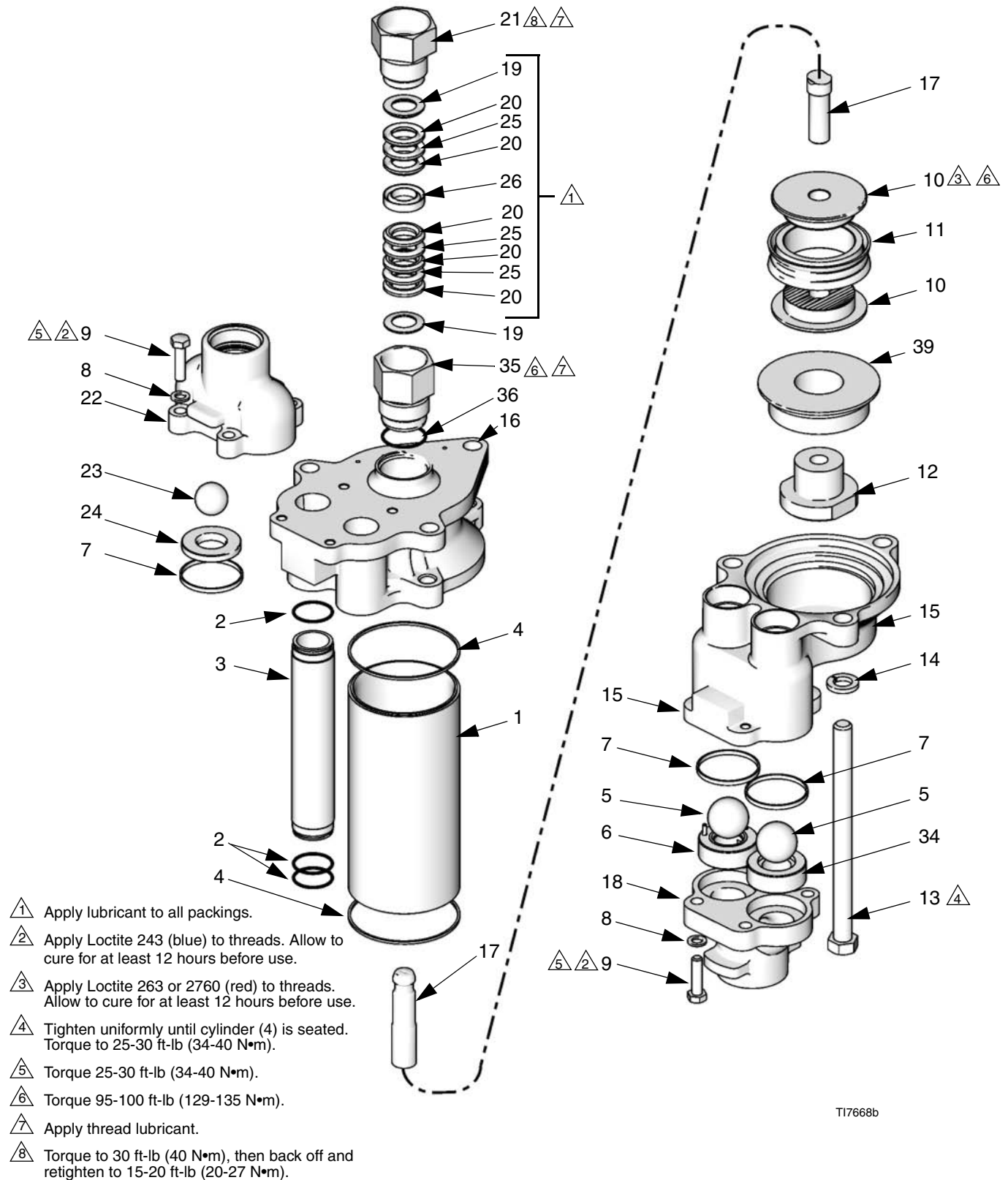

T17668b

FIG. 7

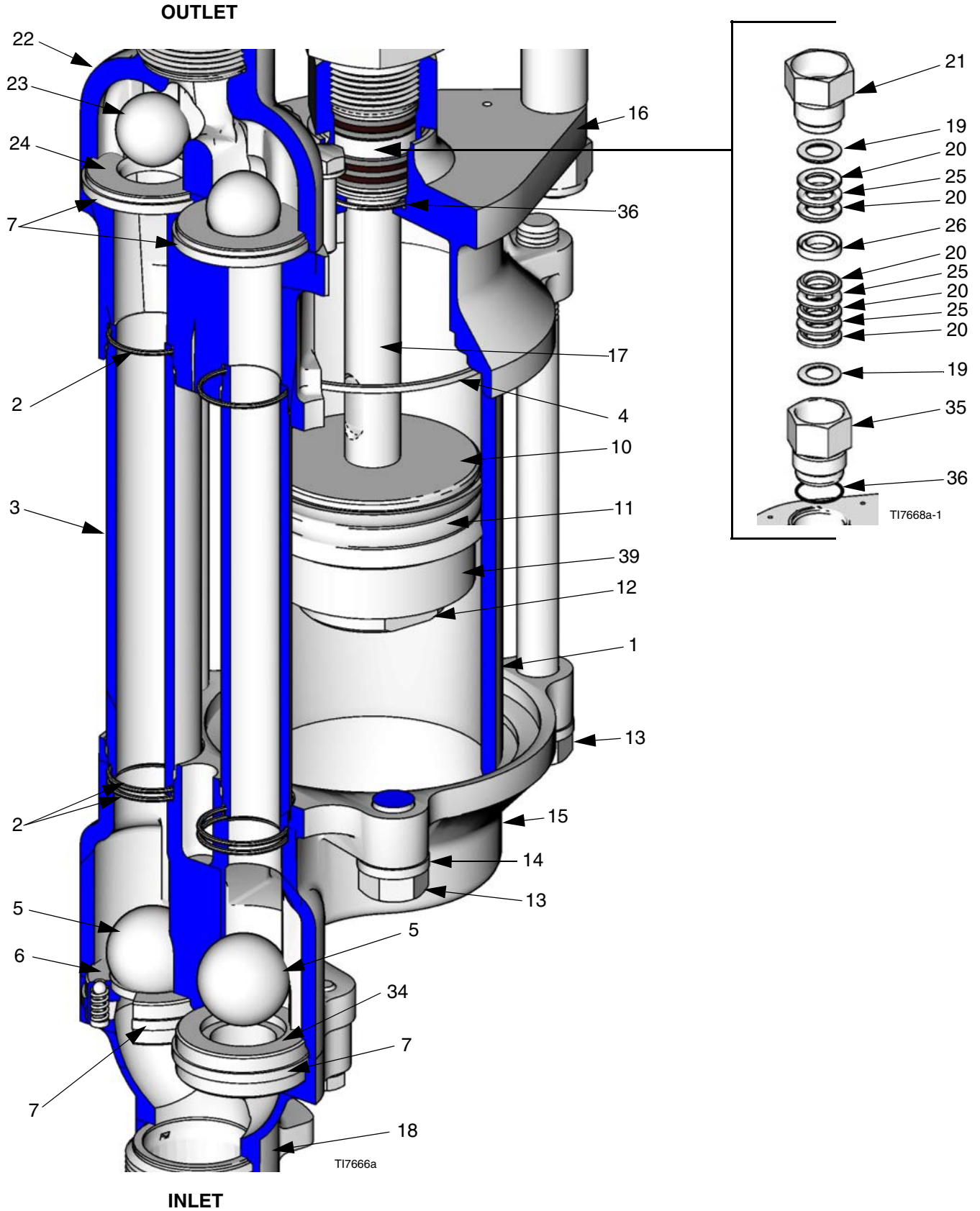

FIG. 8

# Lower Parts

750cc Lower parts list, see page 15

1000cc Lower parts list, see page 16

1500cc Lower parts list, see page 17

2000cc Lower parts list, see page 18

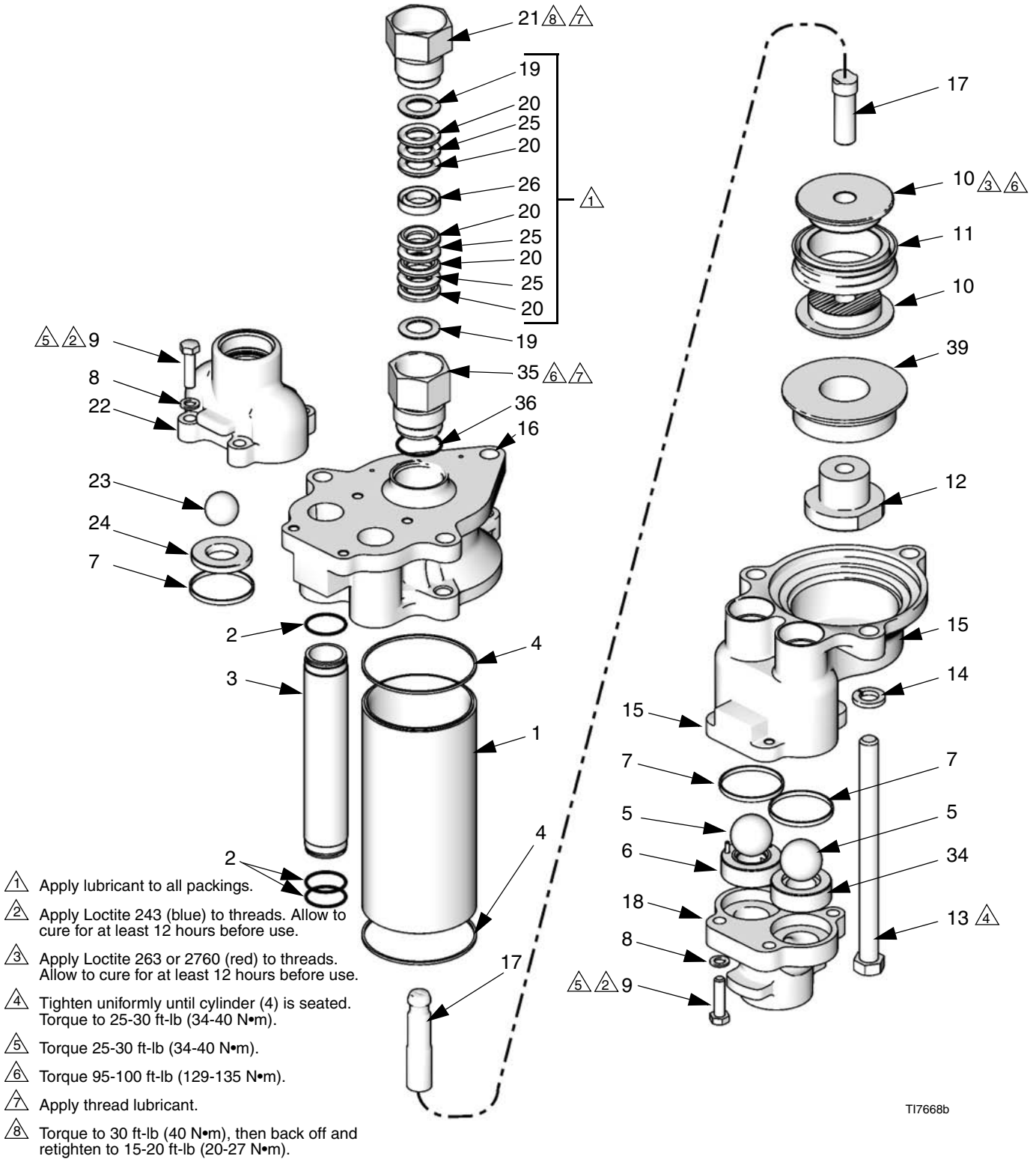

T17668b

## 750cc Lowers

## Part No. 289366, Series A, Stainless Steel

Ref. No.	Part No.	Description	Qty.
1	183049	CYLINDER, pump, sst	1
2*	108526	PACKING, o-ring; PTFE	6
3	183085	TUBE, fluid; sst	2
4*	181875	GASKET, cylinder; UHMWPE	2
5	101968	BALL, intake; 1.25 in. dia; sst	2
6	253483	SEAT, intake valve, with relief valve; sst	1
7*	181877	GASKET, seat, valve; UHMWPE	4
8	111003	WASHER, flat; 8.4 mm; sst	8
9	112084	CAPSCREW, hex hd; M8 x 1.25 x 25; sst	8
10	183081	PISTON; 2.5 in.; sst	2
11*	181680	PACKING, piston; 2.5 in.; UHMWPE	1
12	108528	NUT, piston; hex hd; sst	1
13	108523	CAPSCREW, hex hd; 9/16-12 unc x 7.5 in.; sst	3
14	108525	LOCKWASHER, spring; 9/16 in.; sst	3
15	181905	HOUSING, inlet; sst	1
16	192512	HOUSING, outlet; sst	1
17	16A462	ROD, piston; sst	1
18	15H663	MANIFOLD, inlet; sst	1
19†	192263	GLAND, male; sst	2
20†	183295	V-PACKING, throat; UHMWPE	5
21	181684	NUT, packing; sst	1
22	15H664	MANIFOLD, outlet; sst	1
23	110259	BALL, outlet; 1 in. (25 mm) dia.; sst	2
24	15H746	SEAT, valve; tungsten carbide	2
25†	120238	V-PACKING, throat; leather	3
26†	192264	GLAND, female; sst	1
34	239865	SEAT, intake valve; sst	1
35	192490	ADAPTER; sst	1
36†	107313	PACKING, o-ring; PTFE	1
37▲	172479	TAG, warning (not shown)	1

▲ Replacement Danger and Warning labels, tags, and cards are available at no cost.

\* Parts included in Seal Repair Kit (purchase separately). See page 20.

† Parts included in Throat Packing Repair Kit (purchase separately). See page 21.

## 1000cc Lowers

Part No. 253033, Series A, Stainless Steel

Part No. 253061, Series A, Carbon Steel

Part No. 253398, Series A, Stainless Steel

Part No. 253423, Series A, Stainless Steel

Part No. 253520, Series A, Stainless Steel

Part No. 253523, Series A, Stainless Steel

Part No. 253568, Series A, Stainless Steel

Ref. No.	Description	Lower								Qty.
		253033	24E783	253061	253398	253423	253520	253523	253568	
1	CYLINDER, pump, sst	183047	183047		15H452	183047	183047	15H452	15H452	1
	CYLINDER, pump, cst			183032						1
2*	PACKING, o-ring; PTFE	108526	108526	108526	108526	108526	108526	108526	108526	6
3	TUBE, fluid; sst	183085	183085	183085	183085	183085	183085	183085	183085	2
4*	GASKET, cylinder; UMWPE	183094	183094	183094	183094	183094	183094	183094	183094	2
5	BALL, intake; 1.25 in. dia; sst	101968	101968	101968	101968	101968	101968	101968	101968	2
6	SEAT, intake valve, with relief valve; sst	253483	253483	253483	253483	253483	253483	253483	253483	1
7*	GASKET, seat, valve; UHMWPE	181877	181877	181877	181877	181877	181877	181877	181877	4
8	WASHER, flat; 8.4 mm; sst	111003	111003	111003	111003	111003	111003	111003	111003	8
9	CAPSCREW, hex hd; M8 x 1.25 x 25; sst	112084	112084		112084	112084	112084	112084	112084	8
	CAPSCREW, hex hd; M8 x 1.25 x 25; cst			107558						8
10	PISTON; 3 in.; sst	15G883	15G883	15G883	15G883	15G883	15G883	15G883	15G883	2
11*	PACKING, piston; 3 in.; UMWPE	15G886	15G886	15G886	15G886	15G886	15G886	15G886	15G886	1
12	NUT, piston; hex hd; sst	15H989	15H989	15H989	15H989	15H989	15H989	15H989	15H989	1
13	CAPSCREW, hex hd; 9/16-12 unc x 7.5 in.; sst	120199	120199		120199	120199	120199	120199	120199	3
	CAPSCREW, hex hd; 9/16-12 unc x 7.5 in.; cst			120446						3
14	LOCKWASHER, spring; 9/16 in.; sst	108525	108525		108525	108525	108525	108525	108525	3
	LOCKWASHER, spring; 9/16 in.; cst			101333						3
15	HOUSING, inlet; sst	15G770	15G770		15G770	15G770	15G770	15G770	15G770	1
	HOUSING, inlet; cst			15G891						1
16	HOUSING, outlet; sst	15G771	15G771		15G771	15G771	15G771	15G771	15G771	1
	HOUSING, outlet; cst			15G892						1
17	ROD, piston; sst	16A462	16A462	16A462	16A462	16A462	16A462	16A462	16A462	1
18	MANIFOLD, inlet; sst	192259	192259		193205	193205	15H663	15H663	192259	1
	MANIFOLD, inlet; cst			192260						1
19†	GLAND, male; sst	192263	192263	192263	192263	192263	192263	192263	192263	2
20†	V-PACKING, throat; UHMWPE	183295	183295	183295	183295	183295	183295	183295	183295	5
21	NUT, packing; sst	181684	181684	181684	181684	181684	181684	181684	181684	1
22	MANIFOLD, outlet; sst	15G873	15G873		15G874	15G874	15G664	15H664	15G873	1
	MANIFOLD, outlet; cst			181728						1
23	BALL, outlet; 1 in. (25 mm) dia.; sst	110259	110259	110259	110259	110259	110259	110259	110259	2
24	SEAT, valve; tungsten carbide	15H746		15H746	15H746	15H746	15H746	15H746	15H746	2
	SEAT, valve; sst		183095							2
25†	V-PACKING, throat; leather	120238	120238	120238	120238	120238	120238	120238	120238	3
26†	GLAND, female; sst	192264	192264	192264	192264	192264	192264	192264	192264	1
34	SEAT, intake valve; sst	239865	239865	239865	239865	239865	236865	239865	239865	1
35	ADAPTER; sst	192490	192490	192490	192490	192490	192490	192490	192490	1
36†	PACKING, o-ring; PTFE	107313	107313	107313	107313	107313	107313	107313	107313	1
37▲	TAG, warning (not shown)	172479	172479	172479	172479	172479	172479	172479	172479	1
39	SPACER	16D850	16D850	16D850	16D850	16D850	16D850	16D850	16D850	1

▲ Replacement Danger and Warning labels, tags, and cards are available at no cost.

\* Parts included in Seal Repair Kit (purchase separately). See page 20.

† Parts included in Throat Packing Repair Kit (purchase separately). See page 21.



## 1500cc Lowers

Part No. 253034, Series A, Stainless Steel

Part No. 253062, Series A, Carbon Steel

Part No. 253085, Series A, Stainless Steel

Part No. 253397, Series A, Stainless Steel

Part No. 253521, Series A, Stainless Steel

Part No. 253524, Series A, Stainless Steel

Part No. 253569, Series A, Stainless Steel

Ref. No.	Description	Lower								Qty.
		253034	24E784	253062	253085	253397	253521	253524	253569	
1	CYLINDER, pump, sst	183048	183048		183048	15H453	183048	15H453	15H453	1
	CYLINDER, pump, cst			181900						1
2*	PACKING, o-ring; PTFE	108526	108526	108526	108526	108526	108526	108526	108526	6
3	TUBE, fluid; sst	183085	183085	183085	183085	183085	183085	183085	183085	2
4*	GASKET, cylinder; UMWPE	181876	181876	181876	181876	181876	181876	181876	181876	2
5	BALL, intake; 1.25 in. dia; sst	101968	101968	101968	101968	101968	101968	101968	101968	2
6	SEAT, intake valve, with relief valve; sst	253483	253483	253483	253483	253483	253483	253483	253483	1
7*	GASKET, seat, valve; UHMWPE	181877	181877	181877	181877	181877	181877	181877	181877	4
8	WASHER, flat; 8.4 mm; sst	111003	111003	111003	111003	111003	111003	111003	111003	8
9	CAPSCREW, hex hd; M8 x 1.25 x 25; sst	112084	112084		112084	112084	112084	112084	112084	8
	CAPSCREW, hex hd; M8 x 1.25 x 25; cst			107558						8
10	PISTON; 3.5 in.; sst	15G884	15G884	15G884	15G884	15G884	15G884	15G884	15G884	2
11*	PACKING, piston; 3.5 in.; UMWPE	15G887	15G887	15G887	15G887	15G887	15G887	15G887	15G887	1
12	NUT, piston; hex hd; sst	15H989	15H989	15H989	15H989	15H989	15H989	15H989	15H989	1
13	CAPSCREW, hex hd; 9/16-12 unc x 7.5 in.; sst	120199	120199		120199	120199	120199	120199	120199	3
	CAPSCREW, hex hd; 9/16-12 unc x 7.5 in.; cst			120446						3
14	LOCKWASHER, spring; 9/16 in.; sst	108525	108525		108525	108525	108525	108525	108525	3
	LOCKWASHER, spring; 9/16 in.; cst			101333						3
15	HOUSING, inlet; sst	15G770	15G770		15G770	15G770	15G770	15G770	15G770	1
	HOUSING, inlet; cst			15G891						1
16	HOUSING, outlet; sst	15G771	15G771		15G771	15G771	15G771	15G771	15G771	1
	HOUSING, outlet; cst			15G892						1
17	ROD, piston; sst	16A462	16A462	16A462	16A462	16A462	16A462	16A462	16A462	1
18	MANIFOLD, inlet; sst	192259	192259		192259	193205	15H663	15H663	192259	1
	MANIFOLD, inlet; cst			192260						1
19†	GLAND, male; sst	192263	192263	192263	192263	192263	192263	192263	192263	2
20†	V-PACKING, throat; UHMWPE	183295	183295	183295	183295	183295	183295	183295	183295	5
21	NUT, packing; sst	181684	181684	181684	181684	181684	181684	181684	181684	1
22	MANIFOLD, outlet; sst	15G873	15G873		15G874	15G874	15H664	15H664	15G873	1
	MANIFOLD, outlet; cst			181728						1
23	BALL, outlet; 1 in. (25 mm) dia.; sst	110259	110259	110259	110259	110259	110259	110259	110259	2
24	SEAT, valve; tungsten carbide	15H746		15H746	15H746	15H746	15H746	15H746	15H746	2
	SEAT, valve; sst		183095							2
25†	V-PACKING, throat; leather	120238	120238	120238	120238	120238	120238	120238	120238	3
26†	GLAND, female; sst	192264	192264	192264	192264	192264	192264	192264	192264	1
34	SEAT, intake valve; sst	239865	239865	239865	239865	239865	239865	239865	239865	1
35	ADAPTER; sst	192490	192490	192490	192490	192490	192490	192490	192490	1
36†	PACKING, o-ring; PTFE	107313	107313	107313	107313	107313	107313	107313	107313	1
37▲	TAG, warning (not shown)	172479	172479	172479	172479	172479	172479	172479	172479	1
39	SPACER	16D851	16D851	16D851	16D851	16D851	16D851	16D851	16D851	1

▲ Replacement Danger and Warning labels, tags, and cards are available at no cost.

\* Parts included in Seal Repair Kit (purchase separately). See page 20.

† Parts included in Throat Packing Repair Kit (purchase separately). See page 21.

## 2000cc Lowers

Part No. 253035, Series A, Stainless Steel

Part No. 253063, Series A, Carbon Steel

Part No. 253086, Series A, Stainless Steel

Part No. 253396, Series A, Stainless Steel

Part No. 253522, Series A, Stainless Steel

Part No. 253525, Series A, Stainless Steel

Part No. 253570, Series A, Stainless Steel

Ref. No.	Description	Lower								Qty.
		253035	24E785	253063	253086	253396	253522	253525	253570	
1	CYLINDER, pump, sst	15G882	15G882	15G882	15G882	15H451	15G882	15H451	15H451	1
2*	PACKING, o-ring; PTFE	108526	108526	108526	108526	108526	108526	108526	108526	6
3	TUBE, fluid; sst	183085	183085	183085	183085	183085	183085	183085	183085	2
4*	GASKET, cylinder; UMWPE	15G881	15G881	15G881	15G881	15G881	15G881	15G881	15G881	2
5	BALL, intake; 1.25 in. dia; sst	101968	101968	101968	101968	101968	101968	101968	101968	2
6	SEAT, intake valve, with relief valve; sst	253483	253483	253483	253483	253483	253483	253483	253483	1
7*	GASKET, seat, valve; UHMWPE	181877	181877	181877	181877	181877	181877	181877	181877	4
8	WASHER, flat; 8.4 mm; sst	111003	111003	111003	111003	111003	111003	111003	111003	8
9	CAPSCREW, hex hd; M8 x 1.25 x 25; sst	112084	112084		112084	112084	112084	112084	112084	8
	CAPSCREW, hex hd; M8 x 1.25 x 25; cst			107558						8
10	PISTON; 4 in.; sst	15G885	15G885	15G885	15G885	15G885	15G885	15G885	15G885	2
11*	PACKING, piston; 4 in.; UMWPE	15G888	15G888	15G888	15G888	15G888	15G888	15G888	15G888	1
12	NUT, piston; hex hd; sst	15H989	15H989	15H989	15H989	15H989	15H989	15H989	15H989	1
13	CAPSCREW, hex hd; 9/16-12 unc x 7.5 in.; sst	120199	120199		120199	120199	120199	120199	120199	3
	CAPSCREW, hex hd; 9/16-12 unc x 7.5 in.; cst			120446						3
14	LOCKWASHER, spring; 9/16 in.; sst	108525	108525		108525	108525	108525	108525	108525	3
	LOCKWASHER, spring; 9/16 in.; cst			101333						3
15	HOUSING, inlet; sst	15G770	15G770		15G770	15G770	15G770	15G770	15G770	1
	HOUSING, inlet; cst			15G891						1
16	HOUSING, outlet; sst	15G771	15G771		15G771	15G771	15G771	15G771	15G771	1
	HOUSING, outlet; cst			15G892						1
17	ROD, piston; sst	16A462	16A462	16A462	16A462	16A462	16A462	16A462	16A462	1
18	MANIFOLD, inlet; sst	192259	192259		193205	193205	15H663	15H663	192259	1
	MANIFOLD, inlet; cst			192260						1
19†	GLAND, male; sst	192263	192263	192263	192263	192263	192263	192263	192263	2
20†	V-PACKING, throat; UHMWPE	183295	183295	183295	183295	183295	183295	183295	183295	5
21	NUT, packing; sst	181684	181684	181684	181684	181684	181684	181684	181684	1
22	MANIFOLD, outlet; sst	15G873	15G873		15G874	15G874	15H664	15H664	15G873	1
	MANIFOLD, outlet; cst			181728						1
23	BALL, outlet; 1 in. (25 mm) dia.; sst	110259	110259	110259	110259	110259	110259	110259	110259	2
24	SEAT, valve; tungsten carbide	15H746		15H746	15H746	15H746	15H746	15H746	15H746	2
	SEAT, valve; sst		183095							2
25†	V-PACKING, throat; leather	120238	120238	120238	120238	120238	120238	120238	120238	3
26†	GLAND, female; sst	192264	192264	192264	192264	192264	192264	192264	192264	1
34	SEAT, intake valve; sst	239865	239865	239865	239865	239865	239865	239865	239865	1
35	ADAPTER; sst	192490	192490	192490	192490	192490	192490	192490	192490	1
36†	PACKING, o-ring; PTFE	107313	107313	107313	107313	107313	107313	107313	107313	1
37▲	TAG, warning (not shown)	172479	172479	172479	172479	172479	172479	172479	172479	1
39	SPACER	16D852	16D852	16D852	16D852	16D852	16D852	16D852	16D852	1

▲ Replacement Danger and Warning labels, tags, and cards are available at no cost.

\* Parts included in Seal Repair Kit (purchase separately). See page 20.

† Parts included in Throat Packing Repair Kit (purchase separately). See page 21.



A series of horizontal lines for writing, consisting of 20 evenly spaced lines that span the width of the page.

# Pump Seal Kits

## Pump Seal Repair Kit 289548 Pump PTFE Seal Conversion Kit 289549

Lower Model 289366

Part No.	Description	Qty.
181877	GASKET, seat, valve	4
108526	PACKING, o-ring	6
181875	SEAL, gasket, cylinder	2
181680	PACKING, piston, 2.5 in., UHMWPE (Kit 289548)	1
187761	PACKING, piston, 2.5 in., PTFE (Kit 289549)	1

## Pump Seal Repair Kit 277360 Pump PTFE Seal Conversion Kit 277361

Lower Models: 253033, 253061, 253398, 253423, 253520, 253523, 253568

Part No.	Description	Qty.
181877	GASKET, seat, valve	4
108526	PACKING, o-ring	6
183094	GASKET, cylinder	2
15G886	PACKING, piston, 3 in., UHMWPE (Kit 277360)	1
15H467	PACKING, piston, 3 in., PTFE (Kit 277361)	1

## Pump Seal Repair Kit 277362 Pump PTFE Seal Conversion Kit 277363

Lower Models: 253034, 253062, 253085, 253397, 253521, 253524, 253569

Part No.	Description	Qty.
181877	GASKET, seat, valve	4
108526	PACKING, o-ring	6
181876	GASKET, cylinder	2
15G887	PACKING, piston, 3.5 in., UHMWPE (Kit 277362)	1
15H468	PACKING, piston, 3.5 in., PTFE (Kit 277363)	1

## Pump Seal Repair Kit 277358 Pump PTFE Seal Conversion Kit 277359

Lower Models: 253035, 253063, 253086, 253396, 253522, 253525, 253570

Part No.	Description	Qty.
181877	GASKET, seat, valve	4
108526	PACKING, o-ring	6
15G881	SEAL, gasket, cylinder	2
15G888	PACKING, piston, 4 in., UHMWPE (Kit 277358)	1
15H469	PACKING, piston, 4 in., PTFE (Kit 277359)	1

# Throat Packing Kits

## Throat Packing Kit 239868

With leather throat packings.  
For pumps with 750cc lowers.

Part No.	Description	Qty.
192264	GLAND, female	1
183294	PACKING, vee, leather	8
192263	GLAND, male	2
107313	PACKING, o-ring	1

## Throat Packing Kit 239872

With leather and UHMWPE throat packings.  
For pumps with 750cc lowers.

Part No.	Description	Qty.
192264	GLAND, female	1
183295	PACKING, vee, uhmwpe	5
183294	PACKING, vee, leather	3
192263	GLAND, male	2
107313	PACKING, o-ring	1

## Throat Packing Kit 239866

With PTFE throat packings.  
For pumps with 750cc, 1000cc, 1500cc and 2000cc lowers.

Part No.	Description	Qty.
192264	GLAND, female	1
183352	PACKING, vee, ptf	8
192263	GLAND, male	2
107313	PACKING, o-ring	1

## Throat Packing Kit 277356

With leather throat packings.  
For pumps with 1000cc, 1500cc and 2000cc lowers.

Part No.	Description	Qty.
192264	GLAND, female	1
120238	PACKING, vee, leather	8
192263	GLAND, male	2
107313	PACKING, o-ring	1

## Throat Packing Kit 277357

With leather and UHMWPE throat packings.  
For pumps with 1000cc, 1500cc and 2000cc lowers.

Part No.	Description	Qty.
192264	GLAND, female	1
183295	PACKING, vee, uhmwpe	5
120238	PACKING, vee, leather	3
192263	GLAND, male	2
107313	PACKING, o-ring	1

## Throat Packing Kit 24C405

With UHMWPE and PTFE throat packings.  
For pumps with 750cc, 1000cc, 1500cc and 2000cc lowers.

Part No.	Description	Qty.
192264	GLAND, female	1
183295	PACKING, vee, uhmwpe	5
183352	PACKING, vee, ptf	3
192263	GLAND, male	2
107313	PACKING, o-ring	1

# Graco Standard Warranty

Graco warrants all equipment referenced in this document which is manufactured by Graco and bearing its name to be free from defects in material and workmanship on the date of sale to the original purchaser for use. With the exception of any special, extended, or limited warranty published by Graco, Graco will, for a period of twelve months from the date of sale, repair or replace any part of the equipment determined by Graco to be defective. This warranty applies only when the equipment is installed, operated and maintained in accordance with Graco's written recommendations.

This warranty does not cover, and Graco shall not be liable for general wear and tear, or any malfunction, damage or wear caused by faulty installation, misapplication, abrasion, corrosion, inadequate or improper maintenance, negligence, accident, tampering, or substitution of non-Graco component parts. Nor shall Graco be liable for malfunction, damage or wear caused by the incompatibility of Graco equipment with structures, accessories, equipment or materials not supplied by Graco, or the improper design, manufacture, installation, operation or maintenance of structures, accessories, equipment or materials not supplied by Graco.

This warranty is conditioned upon the prepaid return of the equipment claimed to be defective to an authorized Graco distributor for verification of the claimed defect. If the claimed defect is verified, Graco will repair or replace free of charge any defective parts. The equipment will be returned to the original purchaser transportation prepaid. If inspection of the equipment does not disclose any defect in material or workmanship, repairs will be made at a reasonable charge, which charges may include the costs of parts, labor, and transportation.

**THIS WARRANTY IS EXCLUSIVE, AND IS IN LIEU OF ANY OTHER WARRANTIES, EXPRESS OR IMPLIED, INCLUDING BUT NOT LIMITED TO WARRANTY OF MERCHANTABILITY OR WARRANTY OF FITNESS FOR A PARTICULAR PURPOSE.**

Graco's sole obligation and buyer's sole remedy for any breach of warranty shall be as set forth above. The buyer agrees that no other remedy (including, but not limited to, incidental or consequential damages for lost profits, lost sales, injury to person or property, or any other incidental or consequential loss) shall be available. Any action for breach of warranty must be brought within two (2) years of the date of sale.

**GRACO MAKES NO WARRANTY, AND DISCLAIMS ALL IMPLIED WARRANTIES OF MERCHANTABILITY AND FITNESS FOR A PARTICULAR PURPOSE, IN CONNECTION WITH ACCESSORIES, EQUIPMENT, MATERIALS OR COMPONENTS SOLD BUT NOT MANUFACTURED BY GRACO.** These items sold, but not manufactured by Graco (such as electric motors, switches, hose, etc.), are subject to the warranty, if any, of their manufacturer. Graco will provide purchaser with reasonable assistance in making any claim for breach of these warranties.

In no event will Graco be liable for indirect, incidental, special or consequential damages resulting from Graco supplying equipment hereunder, or the furnishing, performance, or use of any products or other goods sold hereto, whether due to a breach of contract, breach of warranty, the negligence of Graco, or otherwise.

## **FOR GRACO CANADA CUSTOMERS**

The Parties acknowledge that they have required that the present document, as well as all documents, notices and legal proceedings entered into, given or instituted pursuant hereto or relating directly or indirectly hereto, be drawn up in English. Les parties reconnaissent avoir convenu que la rédaction du présente document sera en Anglais, ainsi que tous documents, avis et procédures judiciaires exécutés, donnés ou intentés, à la suite de ou en rapport, directement ou indirectement, avec les procédures concernées.

# Graco Information

For the latest information about Graco products, visit [www.graco.com](http://www.graco.com).

**TO PLACE AN ORDER**, contact your Graco distributor or call to identify the nearest distributor.

**Phone:** 612-623-6921 **or Toll Free:** 1-800-328-0211 **Fax:** 612-378-3505

*All written and visual data contained in this document reflects the latest product information available at the time of publication.  
Graco reserves the right to make changes at any time without notice.*

Original instructions. This manual contains English. MM 311690

**Graco Headquarters:** Minneapolis

**International Offices:** Belgium, China, Japan, Korea

**GRACO INC. P.O. BOX 1441 MINNEAPOLIS, MN 55440-1441**

Copyright 2006, Graco Inc. is registered to ISO 9001

[www.graco.com](http://www.graco.com)

Revised 02/2011