



ChemSafe™ 1590

Air-Operated Diaphragm Pump

334796A
EN

1.5-inch high purity pump for industrial applications. For professional use only.
Not approved for use in European explosive atmosphere locations.



Important Safety Instructions

Read all warnings and instructions in this manual. **Save these instructions.**

*100 psi (0.7 MPa, 7.0 bar) Maximum Air
Supply Pressure
100 psi (0.7 MPa, 7.0 bar) Maximum
Fluid Working Pressure*

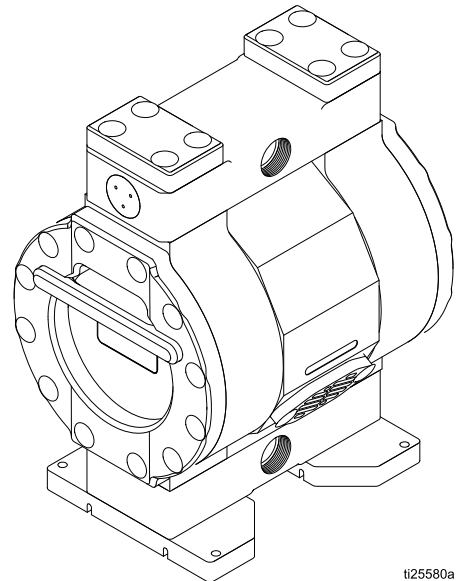

ti25580a



















Contents





Warnings	3	Tighten Threaded Connections	15
Configuration Number Matrix	6	Flushing and Storage	15
Installation.....	8	Troubleshooting.....	16
General Information	8	Repair.....	18
Tighten Bolts	8	Disassemble the Fluid Section	18
Tips to Reduce Cavitation.....	8	Replace the Anchor Strap.....	19
Mount The Pump	9	Disassemble the Center Section	19
Ground The System	10	Replace the Air Motor.....	20
Air Lines	10	Reassemble the Center Section.....	21
Air Exhaust Ventilation	11	Reassemble the Fluid Section.....	22
Fluid Supply Line	12	Torque Instructions	24
Fluid Outlet Line.....	12	Parts.....	25
Operation.....	13	Kits.....	28
Tighten Bolts	13	Dimensions	29
Flush the Pump Before First Use	13	Performance Charts.....	30
Start and Adjust the Pump	13	Technical Data	31
Pressure Relief Procedure.....	14	Graco Standard ChemSafe Pump	
Pump Shutdown	14	Warranty.....	32
Maintenance	15		
Maintenance Schedule	15		
Lubrication.....	15		

Warnings

The following warnings are for the setup, use, grounding, maintenance, and repair of this equipment. The exclamation point symbol alerts you to a general warning and the hazard symbols refer to procedure-specific risks. When these symbols appear in the body of this manual or on warning labels, refer back to these Warnings. Product-specific hazard symbols and warnings not covered in this section may appear throughout the body of this manual where applicable.

 <h2 style="margin: 0;">WARNING</h2>	
    	<p>FIRE AND EXPLOSION HAZARD</p> <p>Flammable fumes, such as solvent and paint fumes, in work area can ignite or explode. To help prevent fire and explosion:</p> <ul style="list-style-type: none"> • Use equipment only in well ventilated area. • Eliminate all ignition sources; such as pilot lights, cigarettes, portable electric lamps, and plastic drop cloths (potential static arc). • Keep work area free of debris, including solvent, rags and gasoline. • Do not plug or unplug power cords, or turn power or light switches on or off when flammable fumes are present. • Ground all equipment in the work area. See Grounding instructions. • Use only grounded hoses. • Hold gun firmly to side of grounded pail when triggering into pail. Do not use pail liners unless they are antistatic or conductive. • Stop operation immediately if static sparking occurs or you feel a shock. Do not use equipment until you identify and correct the problem. • Keep a working fire extinguisher in the work area. • Route exhaust away from all ignition sources. If diaphragm ruptures, fluid may be exhausted with air. <p>Static charge may build up on plastic parts during cleaning and could discharge and ignite flammable vapors. To help prevent fire and explosion:</p> <ul style="list-style-type: none"> • Clean plastic parts only in well ventilated area. • Do not clean with a dry cloth. • Do not operate electrostatic guns in equipment work area.
 	<p>PRESSURIZED EQUIPMENT HAZARD</p> <p>Fluid from the equipment, leaks, or ruptured components can splash in the eyes or on skin and cause serious injury.</p> <ul style="list-style-type: none"> • Follow the Pressure Relief Procedure when you stop spraying/dispensing and before cleaning, checking, or servicing equipment. • Tighten all fluid connections before operating the equipment. • Check hoses, tubes, and couplings daily. Replace worn or damaged parts immediately.

 <h1 style="margin: 0;">WARNING</h1>	
 	<p>EQUIPMENT MISUSE HAZARD</p> <p>Misuse can cause death or serious injury.</p> <ul style="list-style-type: none"> • Do not operate the unit when fatigued or under the influence of drugs or alcohol. • Do not exceed the maximum working pressure or temperature rating of the lowest rated system component. See Technical Data in all equipment manuals. • Use fluids and solvents that are compatible with equipment wetted parts. See Technical Data in all equipment manuals. Read fluid and solvent manufacturer’s warnings. For complete information about your material, request MSDS from distributor or retailer. • Do not leave the work area while equipment is energized or under pressure. • Turn off all equipment and follow the Pressure Relief Procedure when equipment is not in use. • Check equipment daily. Repair or replace worn or damaged parts immediately with genuine manufacturer’s replacement parts only. • Do not alter or modify equipment. Alterations or modifications may void agency approvals and create safety hazards. • Make sure all equipment is rated and approved for the environment in which you are using it. • Use equipment only for its intended purpose. Call your distributor for information. • Route hoses and cables away from traffic areas, sharp edges, moving parts, and hot surfaces. • Do not kink or over bend hoses or use hoses to pull equipment. • Keep children and animals away from work area. • Comply with all applicable safety regulations.
  	<p>THERMAL EXPANSION HAZARD</p> <p>Fluids subjected to heat in confined spaces, including hoses, can create a rapid rise in pressure due to the thermal expansion. Over-pressurization can result in equipment rupture and serious injury.</p> <ul style="list-style-type: none"> • Open a valve to relieve the fluid expansion during heating. • Replace hoses proactively at regular intervals based on your operating conditions.
 	<p>PLASTIC PARTS CLEANING SOLVENT HAZARD</p> <p>Many solvents can degrade plastic parts and cause them to fail, which could cause serious injury or property damage.</p> <ul style="list-style-type: none"> • Use only compatible water-based solvents to clean plastic structural or pressure-containing parts. • See Technical Data in this and all other equipment instruction manuals. Read fluid and solvent manufacturer’s MSDSs and recommendations.

 <h1 style="margin: 0;">WARNING</h1>	
 	<p>TOXIC FLUID OR FUMES HAZARD</p> <p>Toxic fluids or fumes can cause serious injury or death if splashed in the eyes or on skin, inhaled, or swallowed.</p> <ul style="list-style-type: none"> • Read MSDSs to know the specific hazards of the fluids you are using. • Route exhaust away from work area. If diaphragm ruptures, fluid may be exhausted into the air. • Store hazardous fluid in approved containers, and dispose of it according to applicable guidelines.
	<p>BURN HAZARD</p> <p>Equipment surfaces and fluid that's heated can become very hot during operation. To avoid severe burns:</p> <ul style="list-style-type: none"> • Do not touch hot fluid or equipment.
	<p>PERSONAL PROTECTIVE EQUIPMENT</p> <p>Wear appropriate protective equipment when in the work area to help prevent serious injury, including eye injury, hearing loss, inhalation of toxic fumes, and burns. This protective equipment includes but is not limited to:</p> <ul style="list-style-type: none"> • Protective eyewear, and hearing protection. • Respirators, protective clothing, and gloves as recommended by the fluid and solvent manufacturer.

Configuration Number Matrix

Check the identification plate (ID) for the Configuration Number of your pump. Use the following matrix to define the components of your pump.

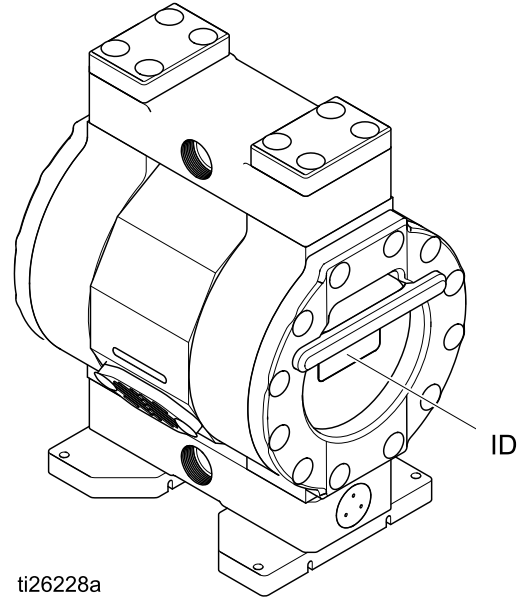

Sample Configuration Number: **1590PT-P01APT3PTPTPOPT**

1590PT	P01A	PT3	PT	PT	PO	PT
Pump Model	Center Section and Air Valve	Fluid Covers and Manifolds	Seats	Balls	Diaphragms	Manifold and Seat Seals

Pump	Center Section and Air Valve Material		Fluid Covers and Manifolds	
1590 PT 1.5 in. PTFE	P01A	Polypropylene center with npt air inlet	PT3	PTFE, npt
1590 UH 1.5 in. UHMWPE	P03A	Polypropylene center with BSPT air inlet	PT4	PTFE, bspt
			UH3	UHMW, npt
			UH4	UHMW, bspt

Seat Material		Ball Material		Diaphragm Material		Manifold and Seat Seal Material	
PT	PTFE	PT	PTFE	BN	Buna N	PT	PTFE
UH	UHMWPE			EP	EPDM		
				PO	PTFE/EPDM Overmolded		

Models

Model	Pump	Air & Fluid Connection Threads	Fluid Covers	Balls	Diaphragm	Manifold Seal		
24X422	1.5 in. PTFE	bspt	PTFE	PTFE	PTFE/EPDM Overmolded	PTFE		
24X421		npt			PTFE/EPDM Overmolded			
24X546		bspt			EPDM			
24X548		npt			Buna N			
24X488		bspt			PTFE/EPDM Overmolded			
24X487		npt			EPDM			
24X486	1.5 in. UHMWPE	bspt	UHMW		PTFE		PTFE/EPDM Overmolded	PTFE
24X485		npt					EPDM	
24X549		bspt					Buna N	
24X551		npt						
24X514		bspt						
24X515		npt						

Installation

General Information

The Typical Installation shown is only a guide for selecting and installing system components. Contact your Graco distributor for assistance in planning a system to suit your needs. Always use Genuine Graco Parts and accessories. Be sure all accessories are adequately sized and pressure rated to meet the system's requirements.

Reference letters in the text, for example (A), refer to the callouts in the figures.

Variations in color between the plastic components of this pump are normal. Color variation does not affect the performance of the pump.

Storage: Pumps that are not put into operation upon delivery must be stored appropriately. See [Flushing and Storage, page 15](#).

Tighten Bolts

Before mounting and using the pump for the first time, check and retorque all external bolts. Remove all protective bolt covers (37). Follow [Torque Instructions, page 24](#), to tighten all bolts. Replace the bolt covers (37). After the first day of operation, retorque the bolts. Retorque the bolts if the pump has been idle for an extended time, been used in thermal cycling applications, been disassembled, or if there is a large difference between environmental temperatures and fluid temperatures.

Tips to Reduce Cavitation

Cavitation in an AODD pump is the formation and collapse of bubbles in the pumped liquid. Frequent or excessive cavitation can cause serious damage, including pitting and early wear of fluid chambers, balls, and seats. It may result in reduced efficiency of the pump. Cavitation damage and reduced efficiency both result in increased operating costs.

Cavitation depends on the vapor pressure of the pumped liquid, the system suction pressure, and the velocity pressure. It can be reduced by changing any of these factors.

1. Reduce vapor pressure: Decrease the temperature of the pumped liquid.
2. Increase suction pressure:
 - a. Lower the installed position of the pump relative to the liquid level in the supply.
 - b. Reduce the friction length of the suction piping. Remember that fittings add friction length to the piping. Reduce the number of fittings to reduce the friction length.
 - c. Increase the size of the suction piping.
3. Reduce liquid velocity: Slow the cyclic rate of the pump.

Pumped liquid viscosity is also very important but normally is controlled by factors that are process dependent and cannot be changed to reduce cavitation. Viscous liquids are more difficult to pump and more prone to cavitation.

Graco recommends taking all the above factors into account in system design. To maintain pump efficiency, supply only enough air pressure to the pump to achieve the required flow.

Graco distributors can supply site specific suggestions to improve pump performance and reduce operating costs.

Mount The Pump



To avoid serious injury from toxic fluid or fumes:

- Ventilate to a remote area. The pump exhaust air may contain contaminants. See [Air Exhaust Ventilation, page 11](#).
- Never move or lift a pump under pressure. If dropped, the fluid section may rupture. Always follow the [Pressure Relief Procedure, page 14](#), before moving or lifting the pump.

1. Be sure the mounting surface can support the weight of the pump, hoses, and accessories, as well as the stress caused during operation.
2. For all mountings, be sure the pump is secured with screws through the mounting feet. Always mount the pump upright.
3. Make sure the surface is flat and that the pump doesn't wobble.
4. For ease of operation and service, mount the pump so air valve, air inlet, fluid inlet and fluid outlet ports are easily accessible.

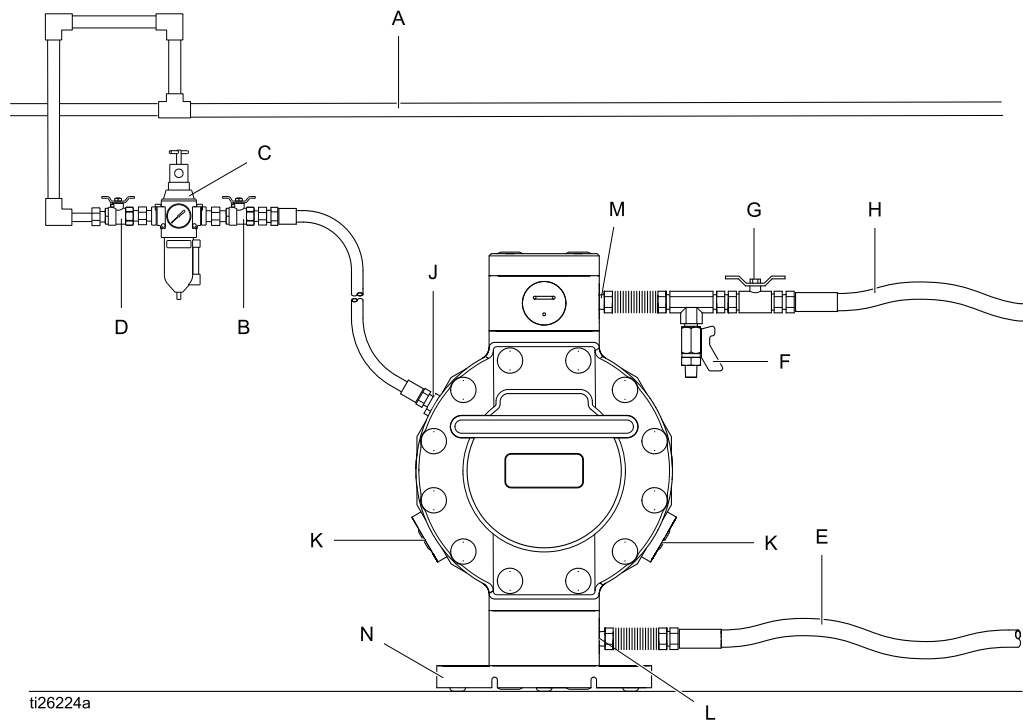

ti26224a

Accessories/Components Not Supplied

- | | |
|---|--|
| A | Air supply line |
| B | Bleed-type master air valve (required for your pump) |
| C | Air filter/regulator assembly |
| D | Master air valve (to isolate the filter/regulator for service) |
| E | Grounded flexible fluid supply line |
| F | Fluid drain valve (required for your pump) |
| G | Fluid shutoff valve |
| H | Grounded, flexible fluid outlet line |

System Components

- | | |
|---|------------------------------|
| J | Air inlet port (not visible) |
| K | Exhaust port and muffler |
| L | Fluid inlet port |
| M | Fluid outlet port |
| N | Mounting feet |

Ground The System

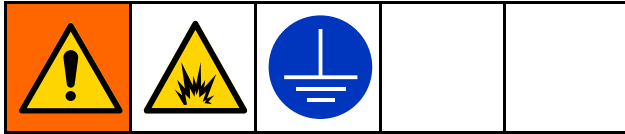

The equipment must be grounded to reduce the risk of static sparking. Static sparking can cause fumes to ignite or explode. Grounding provides an escape wire for the electrical current.

- **Always** ground the entire fluid system as described below.
- The pumps are **not** conductive. Any system used to pump flammable fluids must be properly grounded.
- Follow your local fire codes.

Before operating the pump, ground the system as explained below.

- **Pump:** **Always** ground the entire fluid system by making sure the fluid has an electrical path to a true earth ground.
- **Air and fluid hoses:** Use only flexible grounded hoses with a maximum of 500 ft (150 m) combined hose length to ensure grounding continuity.
- **Air compressor:** Follow manufacturer's recommendations.
- **Fluid supply container:** Follow local code.
- **Solvent pails used when flushing:** Follow local code. Use only conductive metal pails, placed on a grounded surface. Do not place the pail on a nonconductive surface, such as paper or cardboard, which interrupts grounding continuity.

Check your system electrical continuity after the initial installation, and then set up a regular schedule for checking continuity to be sure proper grounding is maintained.

Air Lines



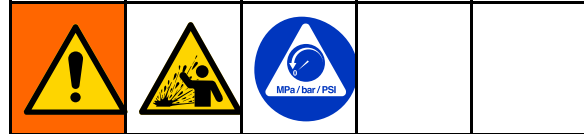

1. Install an air regulator and gauge (C) to control the fluid pressure. The fluid stall pressure will be the same as the setting of the air regulator.
2. Locate a bleed-type master air valve (B) close to the pump and use it to relieve trapped air. Be sure the valve is easily accessible from the pump and located downstream from the regulator.



Trapped air can cause the pump to cycle unexpectedly, which could result in serious injury from splashing.

3. Locate another master air valve (D) upstream from all air line accessories and use it to isolate them during cleaning and repair.
4. An air line filter (C) removes harmful dirt and moisture from the compressed air supply.
5. Install a grounded, flexible air hose (A) between the accessories and the 1/4 npt(f) or 1/4 bspt pump air inlet. Use a hose with a minimum 1/4 in. ID. If a hose longer than 10 ft (3 m) is required, use a larger diameter hose.

Air Exhaust Ventilation

				
<p>If pumping toxic fluids, you must vent the exhaust away from people, animals, food handling areas, and all sources of ignition. Follow all applicable codes.</p>				

NOTE: Do not restrict the air exhaust port. Excessive exhaust restriction can cause erratic pump operation.

To provide a remote exhaust:

1. Use Kit 17F612 (NPT) or 17F613 (BSPT), sold separately.
2. Remove the muffler (U) from the pump air exhaust port (K).
3. Install the adaptor from the kit.
4. Install a grounded air exhaust hose (S). If a hose longer than 10 ft (3 m) is required, use a larger diameter hose. Avoid sharp bends or kinks in the hose.
5. Place a container (T) at the end of the air exhaust line to catch fluid in case a diaphragm ruptures. If the diaphragm ruptures, the fluid being pumped will exhaust with the air.

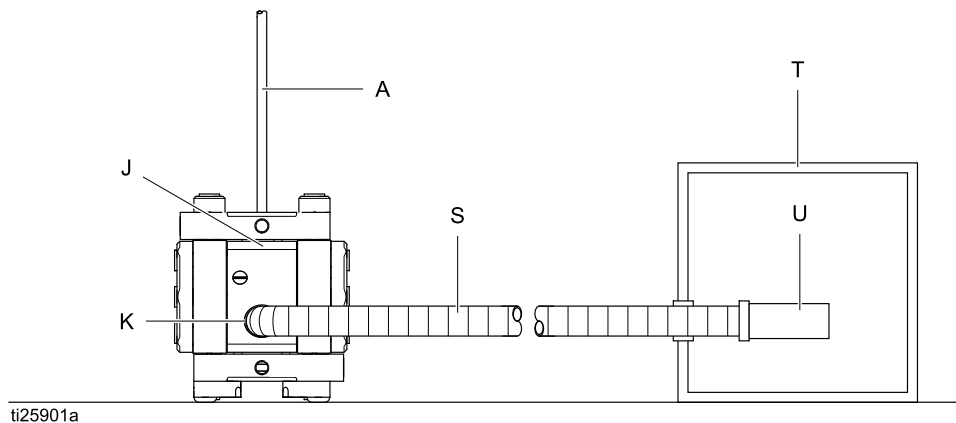

J Air inlet port (not visible)
 K Exhaust port
 S Grounded air exhaust hose

T Container for remote air exhaust
 U Muffler

Fluid Supply Line

1. Use grounded, flexible fluid hoses (E). See [Ground The System, page 10](#).
2. If the inlet fluid pressure to the pump is more than 25% of the outlet working pressure, the ball check valves will not close fast enough, resulting in inefficient pump operation. Excessive inlet fluid pressure also will shorten diaphragm life. Approximately 3–5 psi (0.02–0.03 MPa, 0.21–0.34 bar) should be adequate for most materials.
3. For maximum suction lift (wet and dry), see [Technical Data, page 31](#). For best results, always

install the pump as close as possible to the material source. Minimize suction requirements to maximize pump performance.

Fluid Outlet Line

1. Use grounded, flexible fluid hoses. See [Ground The System, page 10](#),
2. Install a fluid drain valve (F) near the fluid outlet.
3. Install a shutoff valve (G) in the fluid outlet line.

Operation

Tighten Bolts

Before mounting and using the pump for the first time, check and retorque all external bolts. Remove all protective bolt covers (37). Follow [Torque Instructions, page 24](#), to tighten all bolts. Replace the bolt covers (37). After the first day of operation, retorque the bolts. Retorque the bolts if the pump has been idle for an extended time, been used in thermal cycling applications, been disassembled, or if there is a large difference between environmental temperatures and fluid temperatures.

Flush the Pump Before First Use

The pump was tested in water. If water could contaminate the fluid you are pumping, flush the pump thoroughly with a compatible solvent. See [Flushing and Storage, page 15](#).

Start and Adjust the Pump

NOTICE

To avoid damage to your pump, be certain that all pumped fluids are compatible with wetted parts. See [Technical Data, page 31](#).

1. Be sure the pump is properly grounded. See [Ground The System, page 10](#).
2. Check fittings to be sure they are tight. Use a compatible liquid thread sealant on male threads.

NOTICE

Do not overtighten fluid inlet and outlet fittings. Soft plastic threads can be stripped easily.

3. Place the suction tube (if used) in fluid to be pumped.

NOTE: If fluid inlet pressure to the pump is more than 25% of outlet working pressure, the ball check valves will not close fast enough, resulting in inefficient pump operation.

NOTICE

Excessive fluid inlet pressure can reduce diaphragm life.

4. Place the end of the fluid hose into an appropriate container.
5. Close the fluid drain valve.
6. Back out the air regulator knob and open all bleed-type master air valves.
7. If the fluid hose has a dispensing device, hold it open.
8. Slowly increase air pressure with the air regulator until the pump just starts to cycle. Allow the pump to cycle slowly until all air is pushed out of the lines and the pump is primed.

NOTE: Use lowest possible air pressure to prime, just enough to cycle the pump. If the pump does not prime as expected, turn air pressure **DOWN**.
9. If you are flushing, run the pump long enough to thoroughly clean the pump and hoses.
10. Close the bleed-type master air valve.

Pressure Relief Procedure



Follow the Pressure Relief Procedure whenever you see this symbol.



This equipment stays pressurized until pressure is relieved manually. To help prevent serious injury from pressurized fluid, such as splashing in the eyes or on skin, follow the Pressure Relief Procedure when you stop pumping and before you clean, check, or service the equipment.

1. Shut off the air supply to the pump.

2. Open the dispensing valve, if used.
3. Open the fluid drain valve to relieve fluid pressure. Have a container ready to catch the drainage.

Pump Shutdown

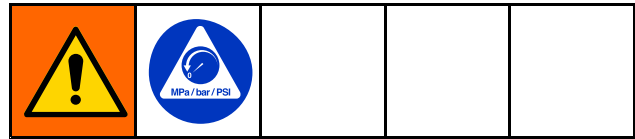

At the end of the work shift and before you check, adjust, clean, or repair the system, follow the [Pressure Relief Procedure, page 14](#).

Maintenance

Maintenance Schedule

Establish a preventive maintenance schedule based on the pump's service history. Scheduled maintenance is especially important to prevent spills or leakage due to diaphragm failure. A clogged muffler may restrict pump performance. Inspect air lines and muffler media regularly to maintain performance.

Lubrication

The pump is lubricated at the factory. It is designed to require no further lubrication for the life of the packings. There is no need to add an inline lubricator under normal operating conditions.

Tighten Threaded Connections

Before each use, check all hoses for wear or damage and replace as necessary. Check to be sure all threaded connections are tight and leak-free. Check mounting bolts. Check bolts. Tighten or retorque as necessary. Although pump use varies, a general guideline is to retorque bolts every two months. See [Torque Instructions, page 24](#).

Flushing and Storage



- Flush before fluid can dry in the equipment, at the end of the day, before storing, and before repairing equipment.
- Flush at the lowest pressure possible. Check connectors for leaks and tighten as necessary.
- Use solvent that is compatible with the equipment wetted parts and the material being dispensed.
- Always flush the pump and relieve the pressure before storing it for any length of time.

NOTICE

Flush the pump often enough to prevent the fluid you are pumping from drying or freezing in the pump and damaging it.

Storage: Pumps must be stored in an environment where they are clean, dry, and protected from extreme temperatures, UV radiation, and vibration. Graco recommends an ambient temperature range of 60°F-80°F (15°C-25°C), with a humidity level below 65%.

Troubleshooting

Problem	Cause	Solution
Pump cycles but will not prime.	Pump is running too fast, causing cavitation before prime.	Lower inlet pressure.
	Check valve ball is severely worn or wedged in seat or manifold.	Replace ball and seat.
	Seat is severely worn.	Replace ball and seat.
	Outlet or inlet is clogged.	Unclog.
	Inlet or outlet valve is closed.	Open.
	Inlet fittings or manifolds are loose.	Tighten.
	Manifold o-rings are damaged.	Replace o-rings.
Pump cycles at stall or fails to hold pressure at stall.	Check valve balls, seats or o-rings are worn.	Replace.
Pump will not cycle, or cycles once and stops.	Spool valve is stuck or dirty.	Disassemble and clean air valve. Use clean dry air.
	Air supply pressure too low.	Increase air supply pressure.
	Spool valve is worn or damaged.	Replace spool valve.
	Check valve ball is severely worn or wedged in seat or manifold.	Replace ball and seat.
	Dispensing valve is clogged.	Relieve pressure and clear valve.
	Diaphragm is ruptured.	Replace.
Pump operates erratically.	Suction line is clogged.	Inspect; clear.
	Check valve balls are sticky or leaking.	Clean or replace.
	Diaphragm is ruptured.	Replace.
	Exhaust is restricted.	Remove restriction.
	Spool valve is damaged or worn.	Replace spool valve.
	Air supply is erratic.	Repair air supply.
	Exhaust muffler is icing.	Use drier air supply.
Air bubbles in fluid.	Suction line is loose.	Tighten.
	Diaphragm is ruptured.	Replace.
	Manifolds are loose, or seats or manifold o-rings are damaged.	Tighten manifold bolts or replace seats and/or o-rings.
	Diaphragm glide seals or o-rings are damaged.	Replace.
	Pump is cavitating.	Reduce pump speed, increase suction hose diameter, or increase inlet head.
Exhaust air contains fluid being pumped.	Diaphragm is ruptured.	Replace.

Problem	Cause	Solution
Moisture in exhaust air.	Inlet air has high humidity.	Use drier air supply.
Pump exhausts excessive air at stall.	Spool valve seals are worn or damaged.	Replace.
Pump leaks air externally.	Fluid covers are loose.	Retorque.
	Diaphragm is damaged.	Replace.
	Manifold fittings are loose.	Retorque.
Pump leaks fluid externally.	Fluid covers are loose.	Retorque.
	Diaphragms are damaged.	Replace.

Repair



Disassemble the Fluid Section

1. Carefully remove all cap plugs (37). Turn the pump upside-down.
2. Use a 13 mm socket to remove the base plates (12) and the inlet manifold (10).
3. Remove the o-ring seals (17), d-rings (21), and check balls (22) from inlet side of each fluid cover (6).
4. Inspect the inlet ball retainers (20). If necessary to replace, use a hook to remove without scratching the inner bore.
5. Turn over the pump and use a 13 mm socket to remove the manifold retainer (11) and the outlet manifold (8).
6. Inspect both inlet manifold's (10) wearable seats (35), and replace if worn or damaged.

NOTE: Use a small hammer to tap new wearable seats (36) into the manifold (10).

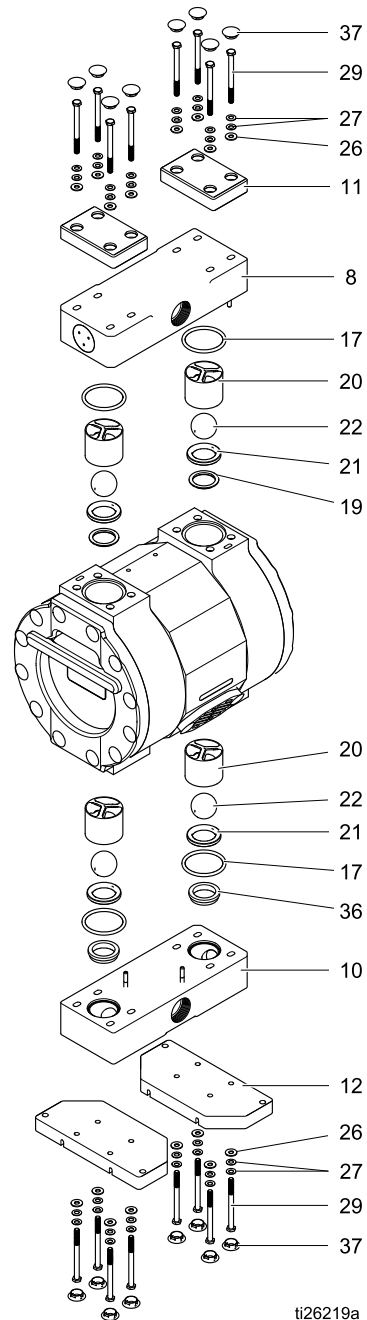

ti26219a

7. Remove the o-ring seal (17) from the outlet side of each fluid cover (6).
8. Without scratching the inner bore, use a hook to remove the two outlet ball retainers (20).
9. Remove the check balls (22), d-rings (21), and wearable seats (19) from the outlet side of each fluid cover (6).

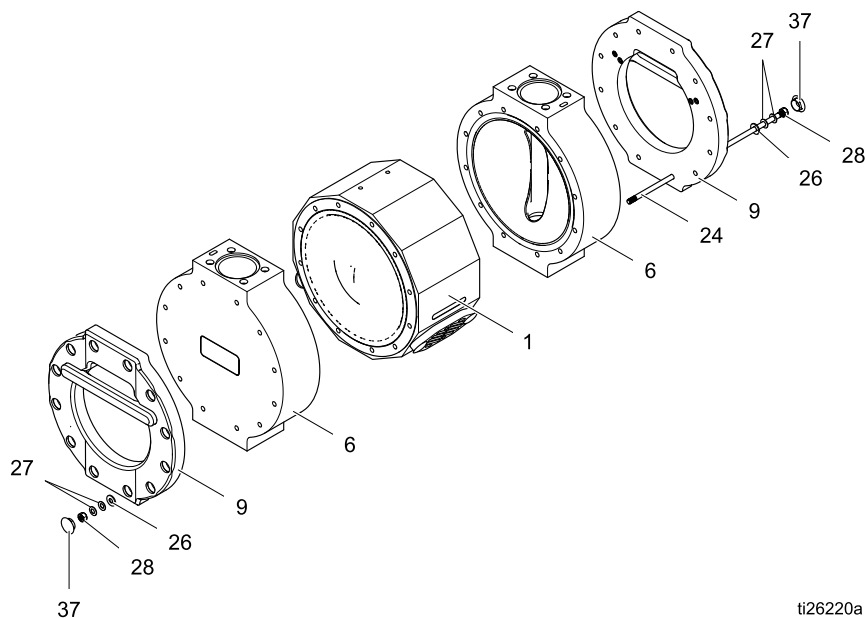

ti26220a

10. To remove the nuts (28) and bolts (24), use two 13 mm wrenches to hold on one side and turn the other. The nuts (28) will come off of one side only. Then remove the bolts (24).

NOTE: The nuts are permanently affixed to one end of the bolts.

11. Remove the fluid cover retainers (9) and the fluid covers (6) from the body (1).

Replace the Anchor Strap

1. While the fluid cover retainers (9) are removed, inspect each anchor strap (31) for damage.
2. If it is necessary to replace an anchor strap, use a 3/16 in. hex wrench to remove the four screws (33) securing the anchor strap (31) to the fluid cover retainer (9).
3. Align the four holes in the new anchor strap (31) with the corresponding holes in the fluid cover retainer (9) and the four screws (33).
4. Use a 3/16 in. hex wrench to tighten the screws (33).

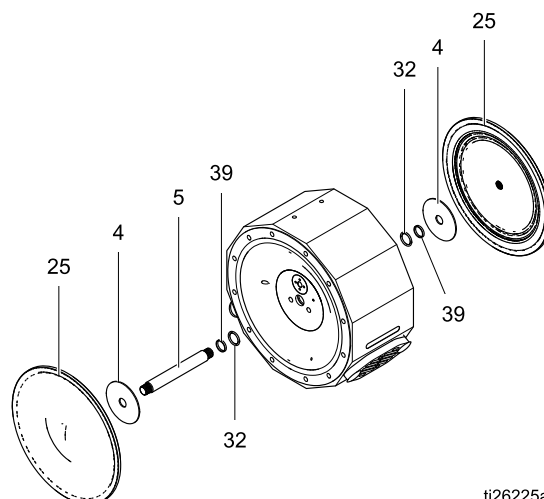

ti26225a

2. Inspect the o-ring seals (32) and glide seals (39). Replace as needed.
3. Carefully remove the cap plugs (37) from both muffler locations.
4. Use a 4 mm Allen wrench to remove the screws (16) and muffler caps (14).
5. Inspect the mesh baffle spacers (38) and felt mufflers (15). Replace as needed.

Disassemble the Center Section

1. One diaphragm (25) and strike plate (4) should screw off by hand. Slide the second diaphragm and strike plate out with the shaft (5).

Repair

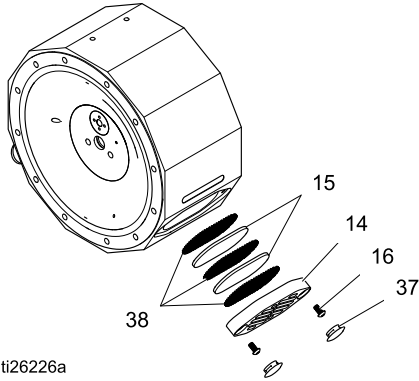

ti26226a

6. Use a 19 mm socket and the supplied tool (42) to remove the sleeve spool assembly (3).

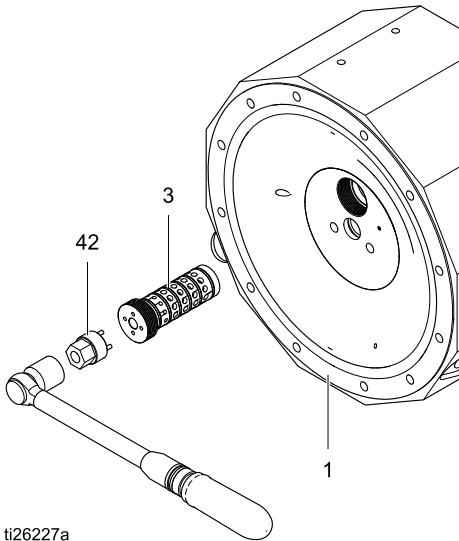

ti26227a

7. Inspect each sleeve spool assembly (3) for worn or damaged parts. Replace each assembly as needed.

Replace the Air Motor

1. Use pin wrench (43) to remove the air motor (2) to remove from the body (1).
2. Inspect o-rings (34), and replace if necessary.
3. Apply a thin film of lubricant to air motor o-rings (34), and to the outside of the air motor (2), and screw back into the body (1), small end first.

NOTE: Be careful not to clog air holes with lubricant.

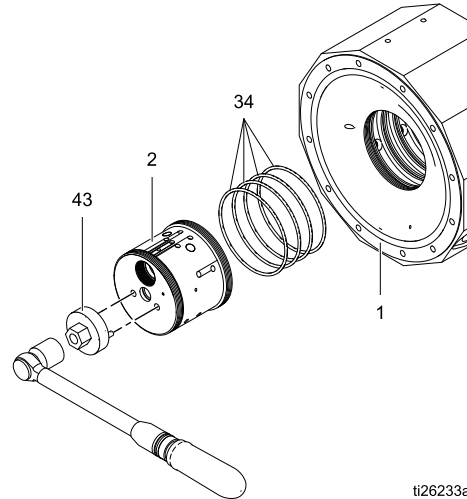

ti26233a

Reassemble the Center Section

1. Carefully lubricate the sleeve spool assembly's o-rings with a thin film of the appropriate lubricant.

NOTE: Be careful not to clog air holes with lubricant.

2. Verify the o-rings on the first sleeve spool assembly (3) are properly seated and carefully insert it into one of the ports of the body's (1) air motor.

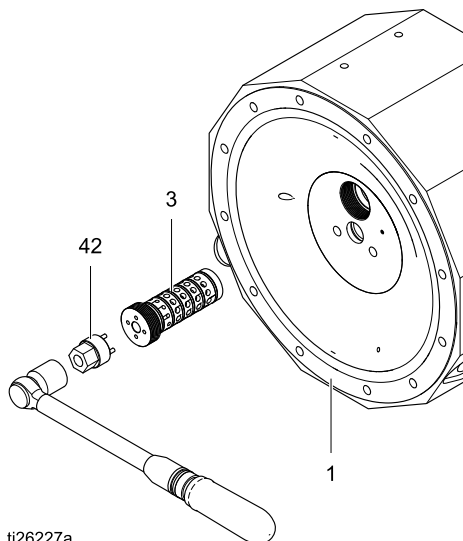

ti26227a

3. Use a 19 mm socket and the supplied tool (42) to tighten the sleeve spool assembly (3) until it is flush with surface of the air motor.

NOTE: Do not overtighten the sleeve spool assembly.

4. Repeat Step 3 for the sleeve spool assembly (3) on the other side of the air motor.
5. Install the muffler media (alternating felt mufflers (15) and mesh baffle spacers (38), as shown) into the muffler. Use the new felt mufflers (15) supplied in the rebuild kit. Muffler parts must be placed in exactly the order shown in the illustration.

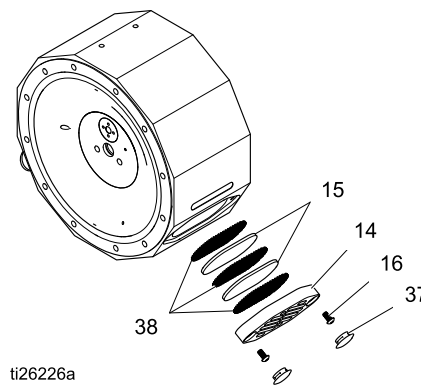

ti26226a

6. Position the muffler cap (14) over the installed muffler media, and use a 4 mm Allen wrench to tighten the screws (16). Torque the screws to 16 in-lbs (1.8 N•m).
7. Repeat Step 6 for the muffler on the other side of the body (1).
8. Lubricate an o-ring seal (32) and place into the ID of the air motor central hole. Lubricate and install a glide shaft seal (39) in the same hole.

NOTE: To avoid damage to the central hole or o-ring grooves, use rubber-tipped needle-nose pliers to form a kidney shape with the glide shaft seal (39) before inserting the seal into the central hole.

9. Repeat Step 8 on the other side of the air motor.
10. Tighten the diaphragm shaft (5) onto one strike plate (4) and diaphragm (25), hand tight only. Do not use any tools on the shaft.

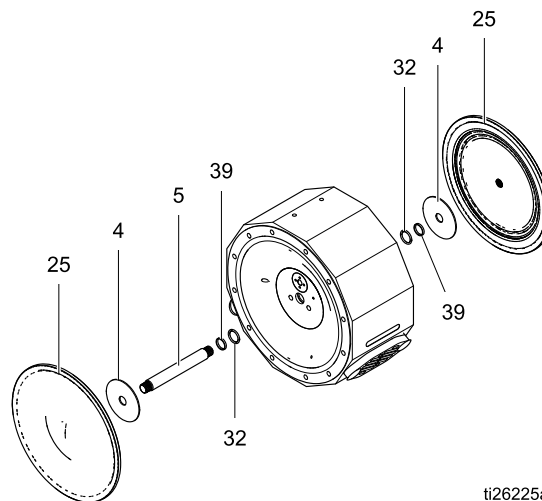

ti26225a

11. Lubricate the shaft, then install it in the air motor. Turn the diaphragm as you push it in. Then, tighten the other diaphragm onto the shaft, hand tight only.

Reassemble the Fluid Section

1. Insert the manifold nuts (18) in the top and bottom of each fluid cover (6). Align the slot in each nut with the corresponding tie bolt hole in each fluid cover.
2. Position the reassembled center section with the inlet side up.

NOTE: The inlet side has two holes in a line for the dowel pins (23). The outlet side has the same two holes arranged diagonally.

3. On each tie bolt (24), place two belleville washers (27), with the rounded side of first washer toward the permanently-attached nut and the rounded side of the second washer away from the nut, then a flat #12 washer (26).

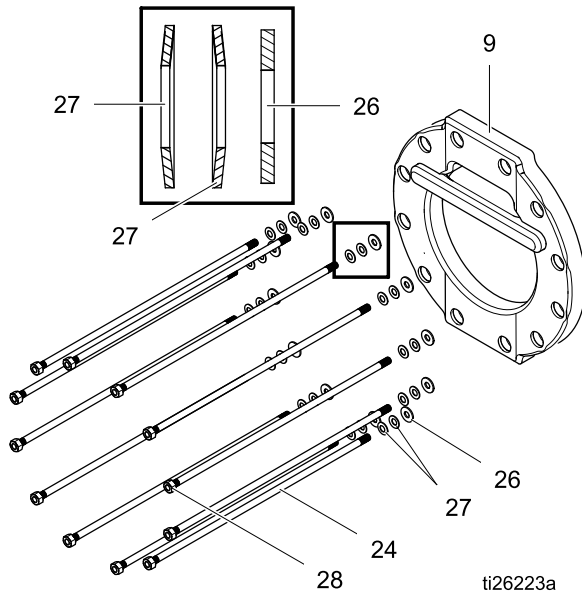

4. Slide the tie bolts (24) through the retainers (9), fluid covers (6), and body (1), all oriented as shown.

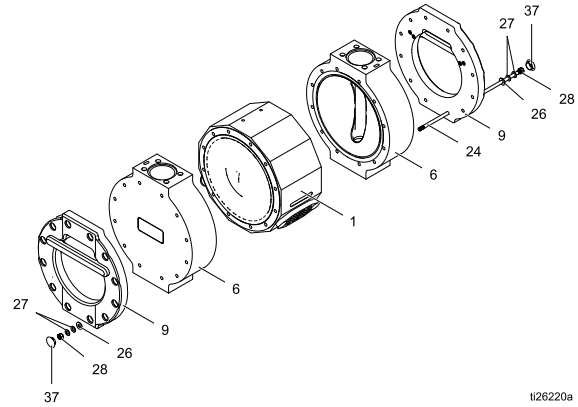

5. On the threaded end of each tie-bolt (24), place a flat #12 washer (26), two belleville washer (27), with the rounded side of the first belleville washer toward the flat washer and the rounded side of the second belleville washer away from the flat washer, and a nut (28). Do not tighten yet.
6. Using a a small hammer and PVC tool (44), tap a wearable seat (19) into place on the outlet side of each fluid cover (6).
7. Insert a d-ring (21), check ball (22), ball retainer (20), and o-ring seal (17) on top of each wearable seat (19).

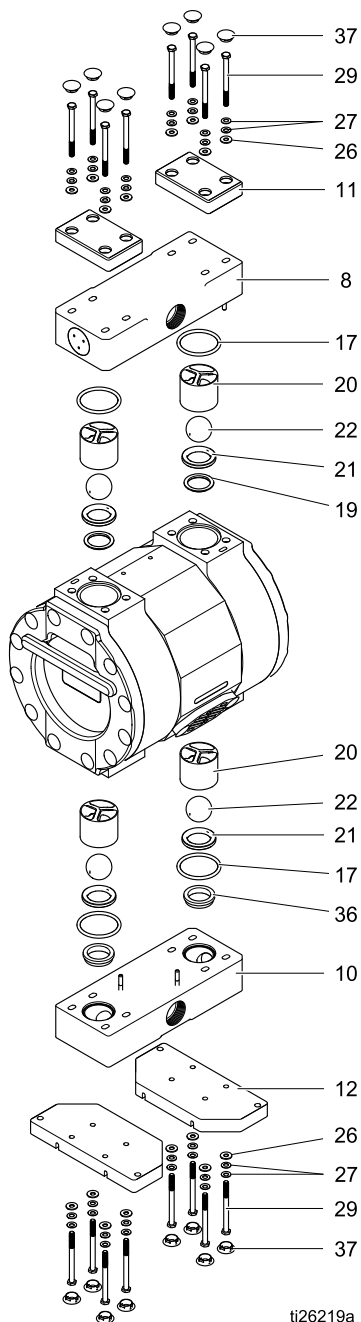

ti26219a

8. Align the outlet manifold (8) on the assembly with the outlet port facing in the correct direction for your application.
9. Align the outlet manifold retainers (11) on the outlet manifold (8).
10. On each screw (29), place two belleville washers (27), with the rounded side of first washer toward the screw head and the rounded side of the second washer away, then a flat #12 washer (26). Thread each screw assembly through an outlet manifold retainer (11) and into the fluid cover (6), and tighten by hand for now.
11. Turn the pump over and insert a ball retainer (20), check ball (22), d-ring (21), and o-ring (17) into the inlet side of each fluid cover (6).
12. Align the inlet manifold (10) on the assembly. Use the placement of dowel pins (23) to orient the manifold so the inlet port is facing the correct direction for your application.
13. Align the inlet manifold retainers (12) on the inlet manifold (10).
14. On each screw (29), place two belleville washers (27), with the rounded side of first washer toward the screw head and the rounded side of the second washer away, then a flat #12 washer (26). Thread each screw assembly through an inlet manifold retainer (11) and into the fluid cover (6), and tighten by hand for now.
15. Follow [Torque Instructions, page 24](#).
16. Replace all bolt covers (37).

Torque Instructions

If fluid cover or manifold bolts have been loosened, it is important to torque them using the following procedure to improve sealing.

NOTICE

Do not over-torque. Tightening the bolts too tight will damage the pump.

NOTE: Always completely torque fluid covers before torquing fluid manifolds.

1. Remove the protective bolt covers (37) with a screwdriver. Carefully work the screwdriver under the lip of each cap and gently pry it off.
2. Start all fluid cover screws a few turns. Then, turn down each screw just until head contacts cover.

Fluid Cover Screws

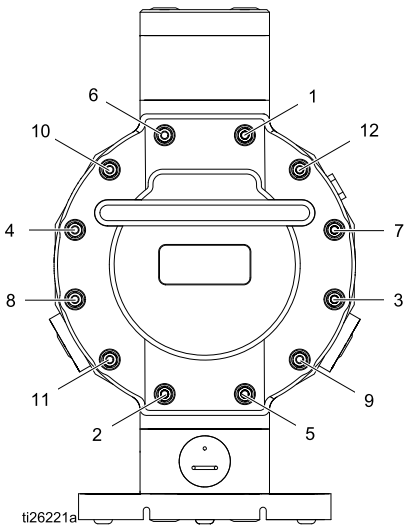

3. Turn each screw by 1/2 turn or less working in a crisscross pattern to specified torque.
4. Repeat for fluid manifolds.

	Assembly Torque	Re-Torque
Fluid Covers	60 in-lb (6.8 N•m)	55 in-lb (6.2 N•m)
Fluid Manifolds	55 in-lb (6.2 N•m)	45 in-lb (5.1 N•m)

Fluid Manifold Screws

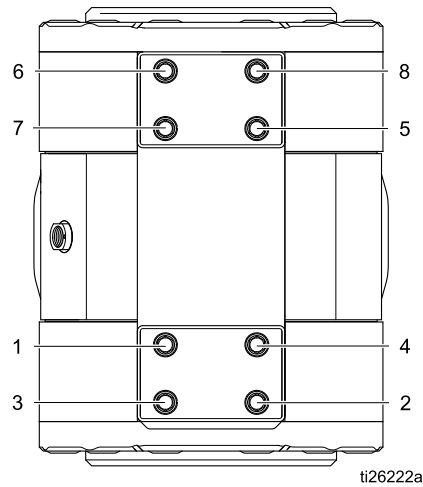

Parts

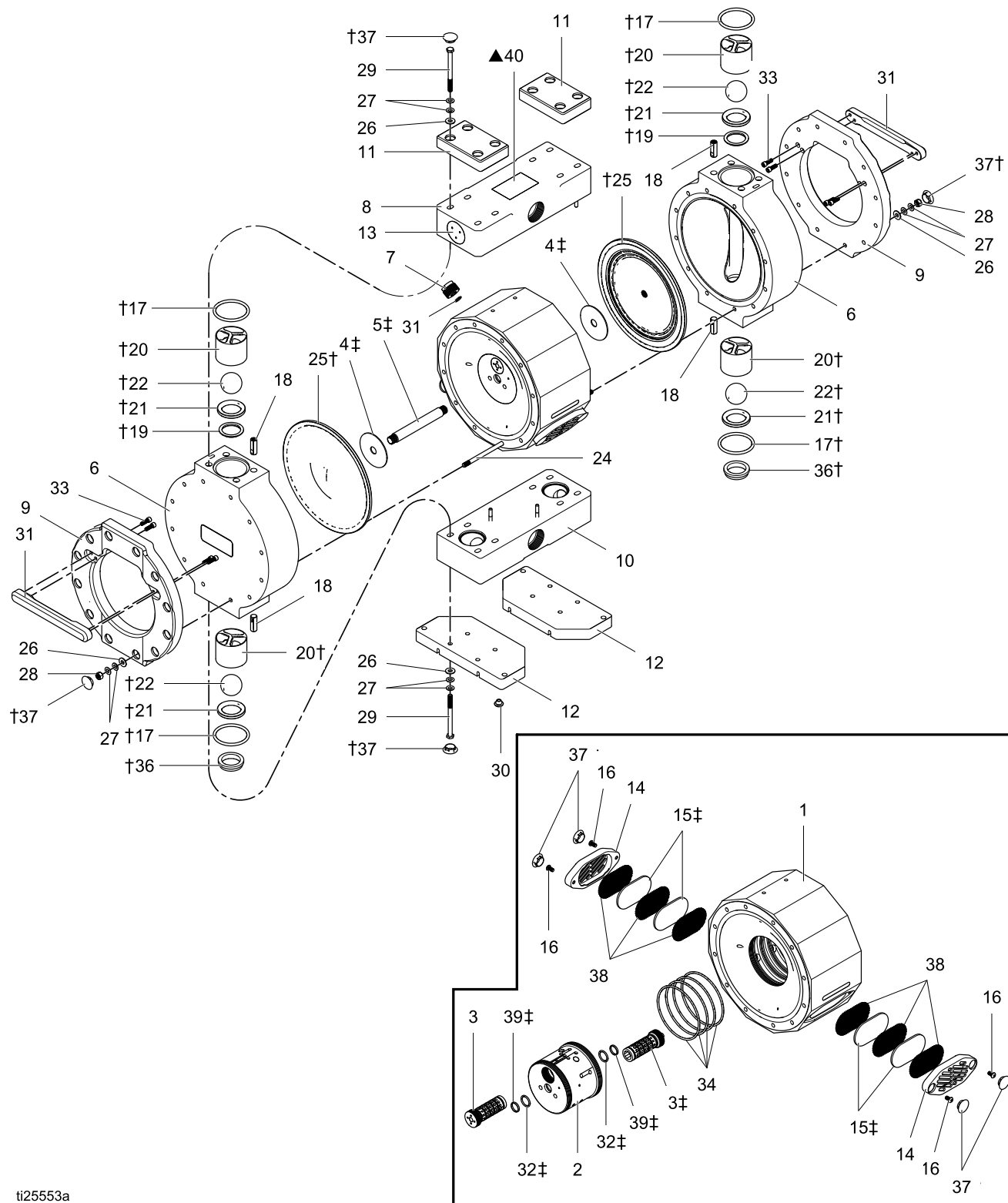

ti25553a

Parts

NOTE: Many parts are included in one or more kits. Please see [Kits, page 28](#), for the complete list of available kits and their contents.

Ref	Part	Description	Qty
1	17F323	BODY, pump, center	1
2	17F064	MOTOR, air	1
3‡	17F006	SPOOL, sleeve; assembly	2
4‡	17F332	PLATE, strike	2
5‡	17F097	SHAFT, diaphragm	1
6	17F156 17F161	COVER, fluid PTFE UHMWPE	2
7	17F090 17F091	ADAPTER, inlet, 1/4 in. NPT BSPT	1
8	17F046 17F045 17F024 17F023	MANIFOLD, outlet PTFE, NPT PTFE, BSPT UMHW, NPT UMHW, BSPT	1
9	17F325	RETAINER, fluid cover	2
10	17F051 17F050 17F026 17F025	MANIFOLD, inlet PTFE, NPT PTFE, BSPT UMHW, NPT UMHW, BSPT	1
11	17F326	RETAINER, manifold	2
12	17F324	PLATE, base	2
13	17F309	PLUG, 1.5 in.; NPT	2
14	17F075	CAP, muffler	2
15‡	17F081	MUFFLER, felt; 2-pack	2
16	17F306	SCREW, button hd; M8 x 1 x 80 lg.	4
17†	17F320	SEAL, o-ring, #331; PTFE	4
18	17F186	NUT, manifold	16

Ref	Part	Description	Qty
19†	— —	SEAT, wearable Modified PTFE UHMW	2
20†	17F106 17F102	RETAINER, ball; 1-5/8 in. PTFE UHMW	4
21†	— —	D-RING PTFE UHMW	4
22†	17F336	BALL, check; 1-5/8 in.; PTFE; 4-pack	1
23	17F307	PIN, guide; .25 dia. x 1.25	6
24	17F177	BOLT, tie	12
25†	17F328 17F327 17F330	DIAPHRAGM, 2-pack Nitrile EPDM PTFE	1
26	17F310	WASHER, M4, flat; 40-pack	1
27	17F311	WASHER, belleville; 80-pack	1
28	17F176	NUT, hex M8	24
29	17F175	SCREW, hex hd cap; M8 x 1 x 80	16
30	17F190	FEET, pump; nitrile; 4-pack	2
31	17F321	STRAP, anchor	2
32‡	17F319	SEAL, o-ring, #117; EPDM	2
33	17F183	SCREW, 1/4-20 x .75, socket head	8
34	17F322	SEAL, o-ring, #246; EPDM	4

Ref	Part	Description	Qty
36†	--	SEAT, wearable, bottom	2
	--	PTFE	
	--	UHMW	
37†	17F308	CAP, plug; 44-pack	1
38	17F078	SPACER, baffle; 6-pack	1
39‡	—	SEAL, glide	2

Ref	Part	Description	Qty
40	188621	LABEL, warning	1
41	198382	LABEL, warning, multilingual	1
42	17F796	TOOL, wrench, spool removal; 4-pin	1
43	17F800	TOOL, wrench, air motor	1

Replacement Warning labels, signs, tags, and cards are available at no cost.

† *Parts included in Fluid Section Rebuild Kit, sold separately. See [Kits, page 28](#), for the correct kit for your pump.*

‡ *Parts included in Center Section Rebuild Kit 17F136, sold separately.*

Kits

Center Section Rebuild Kit 17F136

Kit Includes:

Ref.	Description	Qty
3	Sleeve Spool Assembly	2
4	Strike Plate	2
5	Diaphragm Shaft	1
15	Felt Muffler	4
32	#117 O-ring Seal	4
39	Glide Seal	2

Center Section Optional Rebuild Kit (Air Motor) 17F138

Kit Includes:

Ref.	Description	Qty
2	Air Motor Assembly	1
15	Baffle	6

Fluid Section Rebuild Kits 17F140, 17F142, 17F143, 17F145, 17G053, and 17G054

Kits Include:

Ref.	Description	Qty
25	Diaphragm	2
	PTFE, Kits 17F140, 17F145	
	EPDM, Kits 17F142, 17G053	
	Nitrile; Kits 17F143, 17G054	
17	#326 O-ring	4
36	Wearable Seat, Bottom	2
	PTFE, Kits 17F140, 17G053, 17G054	
	UHMW, Kits 17F142, 17F143, 17F145	
22	Check Ball, 1-5/8 in.; PTFE	4
20	Ball Retainer	4
	PTFE, Kits 17F140, 17G053, 17G054	
	UHMW, Kits 17F142, 17F143, 17F145	
21	D-ring	4
	PTFE, Kit 17F140	
	Modified PTFE, Kits 17G053, 17G054	
	UHMW, Kits 17F142, 17F143, 17F145	

Ref.	Description	Qty
19	Wearable Seat	2
	PTFE, Kits 17F140, 17G053, 17G054	
	UHMW, Kits 17F142, 17F143, 17F145	
37	Plug Cap	44

Spool Assembly Kit 17F588

Kit includes:

Ref.	Description	Qty
-	Spool	1
-	#015 O-Ring	6
-	Glide Seal	6

Air Motor Assembly Kit 17F594

Kit Includes:

Ref.	Description	Qty
2	Air Motor	1
3	Sleeve Spool Assembly	2
-	9/64 in. BB Plug	6
-	.135 Diameter Pin	2
-	.438 Diameter Pin	4

Body Assembly Kit 17G129

Kit Includes:

Ref.	Description	Qty
1	Body	1
-	Air Motor Assembly Kit	1
14	Muffler Cap	2
15	Felt Muffler	4
16	M8 x 1 x 80 lg. Screw	4
34	#246 O-ring	4
37	Cap Plug	4
38	Baffle Spacer	6

Dimensions

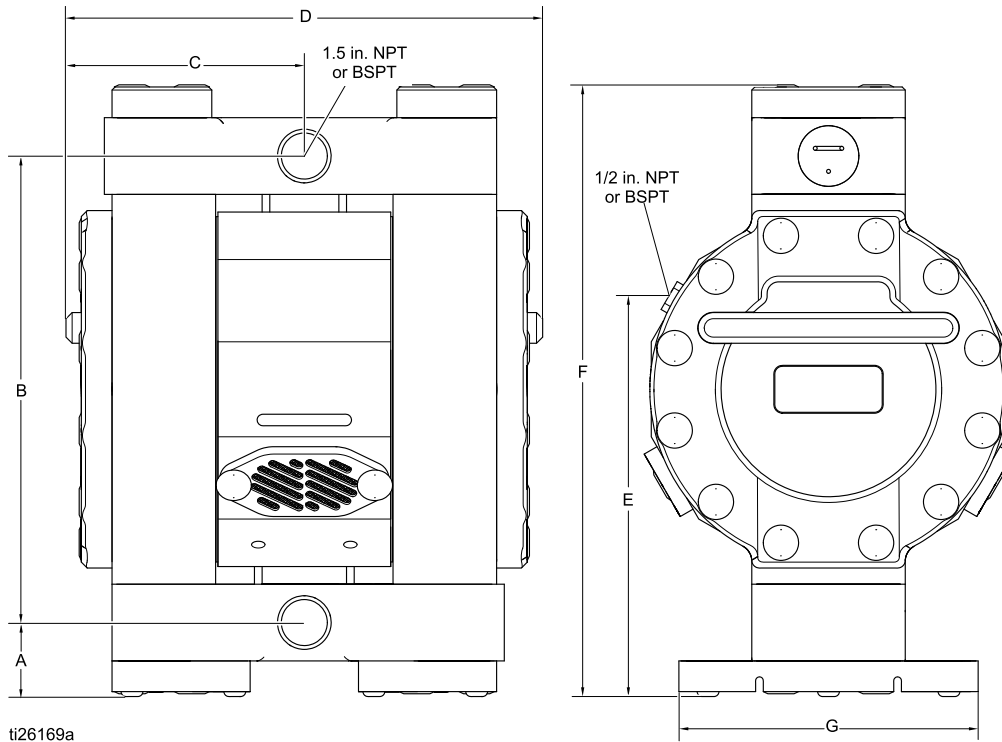

Ref.	US	Metric
A	2.4 in.	6.1 cm
B	15.2 in.	38.6 cm
C	7.8 in.	19.8 cm
D	15.5 in.	39.3 cm
E	13.1 in.	33.2 cm

Ref.	US	Metric
F	20.0 in.	50.8 cm
G	9.8 in.	24.9 cm
H	11.1 in.	28.2 cm
J	9.1 in.	23.1 cm

Performance Charts

Operating Air Pressure

- A**
100 psi (0.7 MPa, 7.0 bar)
- B**
70 psi (0.48 MPa, 4.8 bar)
- C**
40 psi (0.28 MPa, 2.8 bar)

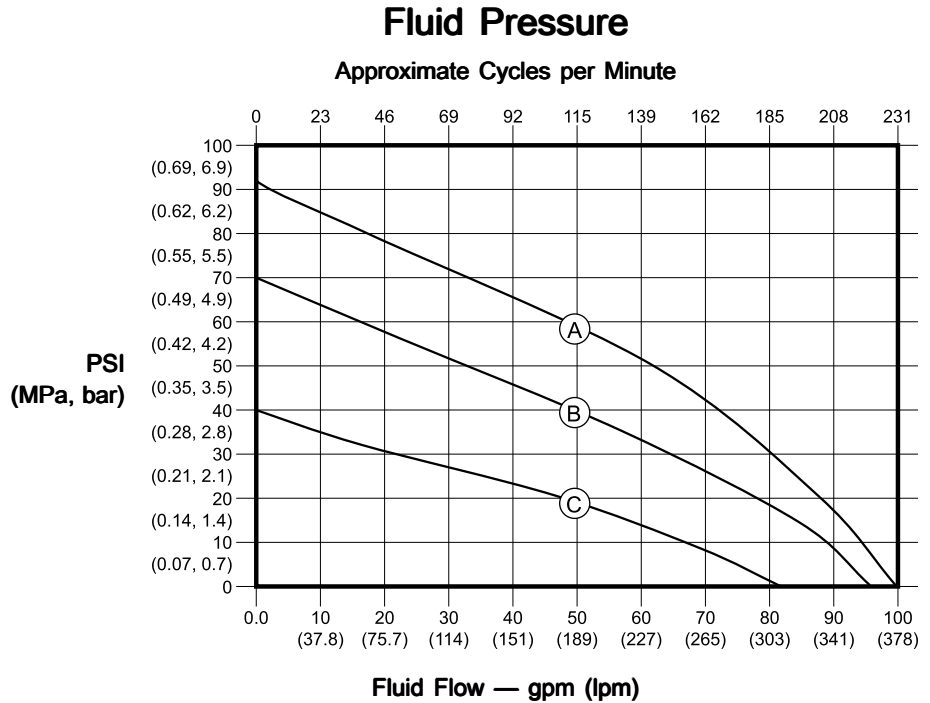

How to Read the Charts

1. Locate fluid flow rate along bottom of chart.
2. Follow vertical line up to intersection with selected operating air pressure curve.
3. Follow left to scale to read **fluid outlet pressure** (top chart) or **air consumption** (bottom chart)

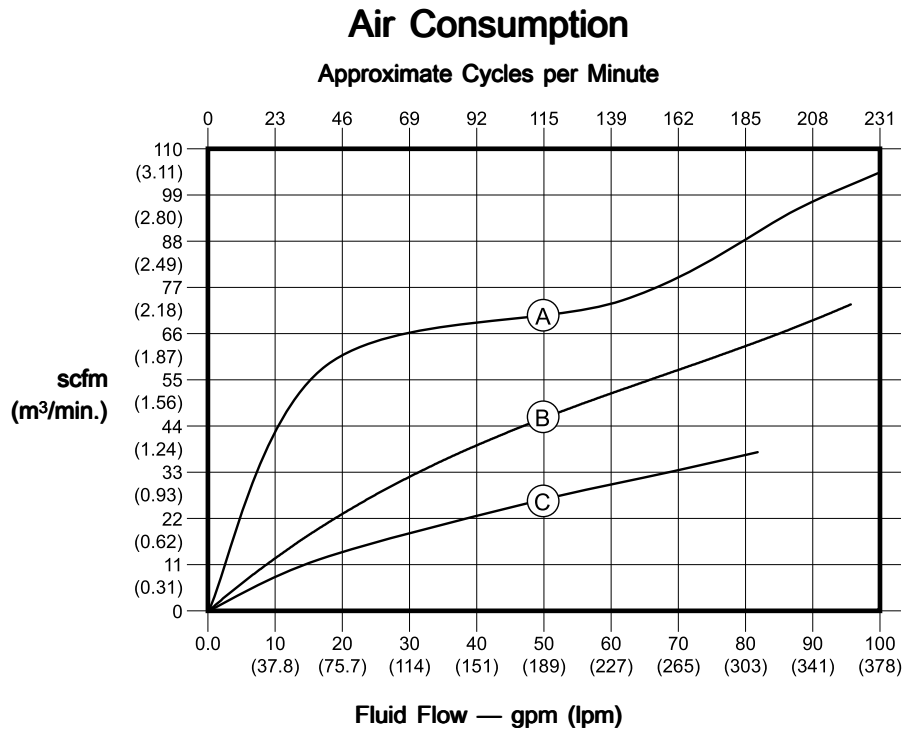

Technical Data

ChemSafe 1590 Diaphragm Pump		
	US	Metric
Maximum fluid working pressure	100 psi	0.69 MPa, 6.9 bar
Minimum air startup pressure	30 psi	0.21 MPa, 2.1 bar
Fluid inlet and outlet size	1 1/2 in. npt	1 1/2 in. bspt
Maximum suction lift (reduced if balls don't seat well due to damaged balls or seats, lightweight balls, or extreme speed of cycling)	Wet: 31.2 ft Dry: 16 ft	Wet: 9.5 m Dry: 4.9 m
Maximum size pumpable solids	0.32 in.	8.1 mm
Minimum recommended ambient air temperature for operation and storage. NOTE: ChemSafe pumps may be operated in low temperature environments. Take care to avoid freezing or crystallization of the fluid inside or outside of the pump. Running the pump at temperatures below freezing may accelerate the wear of the elastomer components in the pump.	32° F	0° C
Air consumption at maximum flow	46 scfm	1.3 sccm
Fluid flow per cycle	0.433 gallons	1.64 liters
Maximum free-flow delivery	99.5 gpm	376 lpm
Maximum pump speed	230 cycles per minute	
Weight	66 lb	30 kg
Wetted Parts	PTFE, EPDM, NBR, UHMWPE	
Maximum fluid temperature		
PTFE Pumps	212° F	100° C
UHMWPE Pumps	158° F	70° C
Noise (dBa) <i>Sound power measured per ISO-9614-2: 1997. Sound pressure was tested 3.28 ft (1 m) from equipment.</i>		
Sound Power		
At 100 cycles per minute	83 dBa	
At 231 cycles per minute	88 dBa	
Sound Pressure		
At 100 cycles per minute	85 dBa	
At 231 cycles per minute	90 dBa	

Graco Standard ChemSafe Pump Warranty

Graco warrants all equipment referenced in this document which is manufactured by Graco and bearing its name to be free from defects in material and workmanship on the date of sale to the original purchaser for use. With the exception of any special, extended, or limited warranty published by Graco, Graco will, for a period of five years from the date of sale, repair or replace any part of the equipment determined by Graco to be defective. This warranty applies only when the equipment is installed, operated and maintained in accordance with Graco's written recommendations.

This warranty does not cover, and Graco shall not be liable for general wear and tear, or any malfunction, damage or wear caused by faulty installation, misapplication, abrasion, corrosion, inadequate or improper maintenance, negligence, accident, tampering, or substitution of non-Graco component parts. Nor shall Graco be liable for malfunction, damage or wear caused by the incompatibility of Graco equipment with structures, accessories, equipment or materials not supplied by Graco, or the improper design, manufacture, installation, operation or maintenance of structures, accessories, equipment or materials not supplied by Graco.

This warranty is conditioned upon the prepaid return of the equipment claimed to be defective to an authorized Graco distributor for verification of the claimed defect. If the claimed defect is verified, Graco will repair or replace free of charge any defective parts. The equipment will be returned to the original purchaser transportation prepaid. If inspection of the equipment does not disclose any defect in material or workmanship, repairs will be made at a reasonable charge, which charges may include the costs of parts, labor, and transportation.

THIS WARRANTY IS EXCLUSIVE, AND IS IN LIEU OF ANY OTHER WARRANTIES, EXPRESS OR IMPLIED, INCLUDING BUT NOT LIMITED TO WARRANTY OF MERCHANTABILITY OR WARRANTY OF FITNESS FOR A PARTICULAR PURPOSE.

Graco's sole obligation and buyer's sole remedy for any breach of warranty shall be as set forth above. The buyer agrees that no other remedy (including, but not limited to, incidental or consequential damages for lost profits, lost sales, injury to person or property, or any other incidental or consequential loss) shall be available. Any action for breach of warranty must be brought within six (6) years of the date of sale..

GRACO MAKES NO WARRANTY, AND DISCLAIMS ALL IMPLIED WARRANTIES OF MERCHANTABILITY AND FITNESS FOR A PARTICULAR PURPOSE, IN CONNECTION WITH ACCESSORIES, EQUIPMENT, MATERIALS OR COMPONENTS SOLD BUT NOT MANUFACTURED BY GRACO. These items sold, but not manufactured by Graco (such as electric motors, switches, hose, etc.), are subject to the warranty, if any, of their manufacturer. Graco will provide purchaser with reasonable assistance in making any claim for breach of these warranties..

In no event will Graco be liable for indirect, incidental, special or consequential damages resulting from Graco supplying equipment hereunder, or the furnishing, performance, or use of any products or other goods sold hereto, whether due to a breach of contract, breach of warranty, the negligence of Graco, or otherwise.

FOR GRACO CANADA CUSTOMERS

The Parties acknowledge that they have required that the present document, as well as all documents, notices and legal proceedings entered into, given or instituted pursuant hereto or relating directly or indirectly hereto, be drawn up in English. Les parties reconnaissent avoir convenu que la rédaction du présente document sera en Anglais, ainsi que tous documents, avis et procédures judiciaires exécutés, donnés ou intentés, à la suite de ou en rapport, directement ou indirectement, avec les procédures concernées.

Graco Information

For the latest information about Graco products, visit www.graco.com.
For patent information, see www.graco.com/patents.

To place an order, contact your Graco Distributor or call to identify the nearest distributor.

Phone: 612-623-6921 **or Toll Free:** 1-800-328-0211 **Fax:** 612-378-3505

All written and visual data contained in this document reflects the latest product information available at the time of publication.

Graco reserves the right to make changes at any time without notice.
Original Instructions. This manual contains English. MM 334795

Graco Headquarters: Minneapolis
International Offices: Belgium, China, Japan, Korea

GRACO INC. AND SUBSIDIARIES • P.O. BOX 1441 • MINNEAPOLIS MN 55440-1441 • USA
Copyright 2015, Graco Inc. All Graco manufacturing locations are registered to ISO 9001.

www.graco.com