



**GRACO**

*First choice when  
quality counts.™*

Rev. C

Supersedes Rev. B



This manual contains important  
warnings and information.  
**READ AND KEEP FOR REFERENCE.**

INSTRUCTIONS

## Viscount® I Hydraulic Motor

*1500 psi (10 MPa, 102 bar) Maximum Hydraulic Input Pressure*

**Model 238-356, Series C**

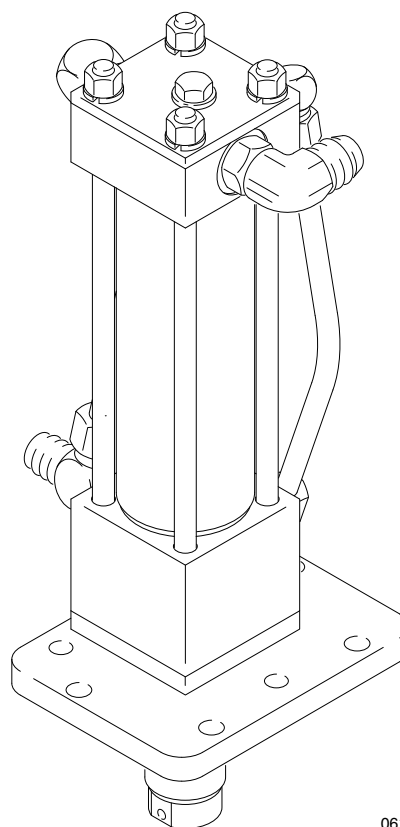

06168

**GRACO INC. P.O. BOX 1441 MINNEAPOLIS, MN 55440-1441**

<http://www.graco.com>

©COPYRIGHT 1996, GRACO INC.

Graco Inc. is registered to I.S. EN ISO 9001



HO03

# Table of Contents

Warnings .....	2	Parts Drawing and Parts List .....	12
Installation .....	5	Accessories .....	14
Operation .....	6	Technical Data .....	14
Troubleshooting .....	7	Graco Standard Warranty .....	16
Service .....	7	Graco Phone Number .....	16
Required Tools .....	7		
Hydraulic Motor Disassembly .....	8		
Hydraulic Motor Reassembly .....	10		

## Symbols

### Warning Symbol



This symbol alerts you to the possibility of serious injury or death if you do not follow the instructions.

### Caution Symbol



This symbol alerts you to the possibility of damage to or destruction of equipment if you do not follow the instructions.

**WARNING**

 <b>INSTRUCTIONS</b>	<p><b>EQUIPMENT MISUSE HAZARD</b></p> <p>Equipment misuse can cause the equipment to rupture or malfunction and result in serious injury.</p> <ul style="list-style-type: none"> <li>● This equipment is for professional use only.</li> <li>● Read all instruction manuals, tags, and labels before operating the equipment.</li> <li>● Use the equipment only for its intended purpose. If you are not sure, call your Graco distributor.</li> <li>● Do not alter or modify this equipment. Use only genuine Graco parts and accessories.</li> <li>● Check equipment daily. Repair or replace worn or damaged parts immediately.</li> <li>● Do not exceed the maximum working pressure stated on the equipment or in the <b>Technical Data</b> for your equipment. Do not exceed the maximum working pressure of the lowest rated component in your system.</li> <li>● Use fluids and solvents which are compatible with the equipment wetted parts. Refer to the <b>Technical Data</b> section of all equipment manuals. Read the fluid and solvent manufacturer's warnings.</li> <li>● Handle hoses carefully. Do not pull on hoses to move equipment.</li> <li>● Route hoses away from traffic areas, sharp edges, moving parts, and hot surfaces. Do not expose Graco hoses to temperatures above 66°C (150°F) or below -40°C (-40°F).</li> <li>● Wear hearing protection when operating this equipment.</li> <li>● Do not move or lift pressurized equipment.</li> <li>● Comply with all applicable local, state, and national fire, electrical, and safety regulations.</li> </ul>
-------------------------	--

# ⚠ WARNING



## INJECTION HAZARD

Spray from the gun, leaks or ruptured components can inject fluid into your body and cause extremely serious injury, including the need for amputation. Fluid splashed in the eyes or on the skin can also cause serious injury.



- Fluid injected into the skin is a serious injury. The injury may look like just a cut, but it is a serious injury. Get immediate medical attention.
- Do not point the gun at anyone or at any part of the body.
- Do not put your hand or fingers over the spray tip.
- Do not stop or deflect leaks with your hand, body, glove or rag.
- Do not “blow back” fluid; this is not an air spray system.
- Always have the tip guard and the trigger guard on the gun when spraying.
- Check the gun diffuser operation weekly. Refer to the gun manual.
- Be sure the gun trigger safety operates before spraying.
- Lock the gun trigger safety when you stop spraying.
- Follow the **Pressure Relief Procedure** on page 6 if the spray tip clogs and before cleaning, checking or servicing the equipment.
- Tighten all fluid connections before operating the equipment.
- Check the hoses, tubes, and couplings daily. Replace worn or damaged parts immediately. Do not repair high pressure couplings; you must replace the entire hose.
- Fluid hoses must have spring guards on both ends, to help protect them from rupture caused by kinks or bends near the couplings.



## MOVING PARTS HAZARD

Moving parts can pinch or amputate your fingers.

- Keep clear of all moving parts when starting or operating the pump.
- Before checking or servicing the equipment, follow the **Pressure Relief Procedure** on page 6 to prevent the equipment from starting unexpectedly.

# WARNING



## FIRE AND EXPLOSION HAZARD

Improper grounding, poor ventilation, open flames or sparks can cause a hazardous condition and result in a fire or explosion and serious injury.



- Ground the equipment and the object being sprayed. Refer to **Grounding** on page 5.
- If there is any static sparking or you feel an electric shock while using this equipment, **stop spraying immediately**. Do not use the equipment until you identify and correct the problem.
- Provide fresh air ventilation to avoid the buildup of flammable fumes from solvents or the fluid being sprayed.
- Keep the spray area free of debris, including solvent, rags, and gasoline.
- Before operating this equipment, electrically disconnect all equipment in the spray area.
- Before operating this equipment, extinguish all open flames or pilot lights in the spray area.
- Do not smoke in the spray area.
- Do not turn on or off any light switch in the spray area while spraying or while operating if fumes are present.
- Do not operate a gasoline engine in the spray area.



## TOXIC FLUID HAZARD

Hazardous fluid or toxic fumes can cause serious injury or death if splashed in the eyes or on the skin, inhaled, or swallowed.

- Know the specific hazards of the fluid you are using.
- Store hazardous fluid in an approved container. Dispose of hazardous fluid according to all local, state and national guidelines.
- Always wear protective eyewear, gloves, clothing and respirator as recommended by the fluid and solvent manufacturer.



# Installation

## General Information

**NOTE:** Reference numbers and letters in parentheses in the text refer to the callouts in the figures and the parts drawing.

**NOTE:** Always use Genuine Graco Parts and Accessories, available from your Graco distributor.

## Grounding

 <b>WARNING</b>	
	<b>FIRE AND EXPLOSION HAZARD</b> Before operating the pump, ground the system as explained below. Also read the section <b>FIRE OR EXPLOSION HAZARD</b> on page 4.

- *Hydraulic power supply:* Follow manufacturer's recommendations.
  - *Spray gun:* Ground through connection to a properly grounded fluid hose and pump.
  - *Fluid supply container:* Follow your local code.
  - *Object being sprayed:* Follow your local code.
  - *Solvent pails used when flushing:* Follow your local code. Use only metal pails, which are conductive, placed on a grounded surface. Do not place the pail on a nonconductive surface, such as paper or cardboard, which interrupts the grounding continuity.
  - *To maintain grounding continuity when flushing or relieving pressure,* hold a metal part of the spray gun firmly to the side of a grounded *metal* pail, then trigger the gun.
- *Pump:* Use a ground wire and clamp. See separate system manual.
  - *Hydraulic, and fluid hoses:* Use only electrically conductive hoses.

# Operation

## Startup

Before each use, check the hydraulic fluid level and add fluid as necessary to fill the lines.

### WARNING



#### FIRE HAZARD

If hydraulic oil becomes too hot, it can reach its flash point and cause a fire.

Operating at too high an oil temperature can also cause faster motor seal wear and leakage. The recommended hydraulic oil operating temperature is 80 to 115°F (27 to 45°C). If the oil temperature approaches 130°F (54°C), shut off the motor and check the hydraulic oil supply cooling system, filters, etc. Clean or repair as needed.

Always use Graco-approved Hydraulic Oil or equivalent (see **Accessories**). Do not substitute a lower grade oil or one with a lower flash point.

The equivalent is a premium, ISO grade 46 petroleum-based hydraulic oil containing rust and oxidation inhibitors and anti-wear agents. Before using any other type of oil in this equipment, call your Graco distributor. **Unauthorized use of lesser grade oil or substitutes will void the warranty.**

## Shutdown and Care

Follow the **Pressure Relief Procedure Warning** below.

## Pressure Relief Procedure

### WARNING

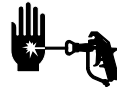

#### INJECTION HAZARD

The system pressure must be manually relieved to prevent the system from starting or spraying accidentally. Fluid under high pressure can be injected through the skin and cause serious injury. To reduce the risk of an injury from injection, splashing fluid, or moving parts, follow the **Pressure Relief Procedure** whenever you:

- are instructed to relieve the pressure,
- stop spraying,
- check or service any of the system equipment,
- or install or clean the spray tip.

1. Engage the gun safety latch.
2. Shut off the hydraulic power supply.
3. Close the supply line shutoff valve, and then the return line shutoff valve.
4. Disengage the gun safety latch.
5. Hold a metal part of the gun firmly to the side of a grounded metal pail, and trigger the gun to relieve pressure.
6. Engage the gun safety latch.
7. Open the drain valve (required in your system), and have a container ready to catch drainage.
8. Leave the drain valve open until you are ready to spray again.

If you suspect that the spray gun or hose is completely clogged or that pressure has not been fully relieved after following the steps above, **very slowly** loosen the hose end coupling and relieve pressure gradually, then loosen completely, then clear the valve or hose.

# Troubleshooting

Problem	Cause	Solution
Hydraulic Motor stops running.	Worn valve or valve balls (3); broken valve spring (18).	Repair valve. See page 8.
	Broken trip rod (17), spring (12) or retainers (11).	Replace parts. See page 8.
Poor performance or reduced efficiency.	Worn piston seals (5, 6, 7).	Replace seals. See page 8.
Oil leaking around cylinder.	Worn cylinder o-rings (2).	Replace o-rings. See page 8.
	Loose tie rods (37).	Tighten nuts (27). See page 10.
Oil leaking around inlet or return tube fittings.	Loose fittings or worn fitting o-rings (31, 34, and 38).	Tighten or replace fittings. See page 8.
Excessive oil in drain bottle, or bottle needs frequent emptying.	Worn seals (2, 15, 14, and 49) in bottom cylinder cap.	Replace seals. See page 8.

## Service

### Required Tools

- Set of allen wrenches
- Set of socket or box wrenches
- Adjustable wrench
- Torque wrench
- Spanner wrench
- O-ring pick
- 10–24 unc–2b tap
- Vise
- Shallow metal or plastic pan (approx. 12 x 20 in.)
- Repair Tool 189–305 (see page 14)
- Thread lubricant
- Lithium-base grease
- Fresh Loctite® 242 thread sealant and Loctite® Primer T or Perma-Loc® 115 thread sealant and Perma-Bond® Surface Conditioner I
- Chlorinated solvent

# Service

## Hydraulic Motor Disassembly

**NOTE:** Repair Kit 236–698 is available. For the best results, use all the parts in the kit. Kit parts are marked with an asterisk, for example (2\*).

**NOTE:** When disassembling, lay out all parts in sequence, to make reassembly easier. Clean and inspect all parts for wear or damage before reassembling. Replace as necessary.

1. Remove the hydraulic motor from the pump as explained in the separate system manual. Lay it on its side in a pan.
2. Unthread the tie rods (37) from the retainer (36) and the tie plate, and pull them out through the top of the hydraulic motor. It will be necessary to remove the lower four nuts (27) and lockwashers (28).
3. Unscrew the four fluid tube nuts (N) and remove the tubes (32, 39). See Fig. 1. Allow excess oil to drain from the hydraulic motor, then plug the fluid fittings.

### CAUTION

#### Keep the hydraulic system clean

Always plug the hydraulic inlets, outlets and lines when disconnecting them for any reason to avoid introducing dirt and other contaminants into the system.

4. Pull the top valve spool (1), cylinder (33), and displacement rod (9) together off the bottom cylinder cap (35). Remove the o-ring (2) from the bottom cap.
5. Grasp the valve spool(1) and pull the cylinder (33) off. Slide the cylinder off the displacement rod (9). Be careful not to damage the rod. Remove the o-ring (2) from the valve spool.
6. Lay the valve spool (1) and displacement rod (9) on a table. Place a clean rag around the yoke (4) to prevent the detent balls (3) from popping out. Push the yoke (4) sideways off the valve sleeve (19) while holding the balls (3) and spring (18) with the rag, then carefully remove the balls and spring.

7. Inspect the valve sleeve (19), valve stop (25), and spool (S) for damage. See Fig. 2. If any of these parts requires replacement, unscrew the two screws (26) holding the stop (25) to the spool (S). Remove the stop and slide the sleeve (19) off the spool. If the spool is damaged, replace the valve spool (1).

**NOTE:** If any of these parts are being reused, thoroughly clean any adhesive residue from the screws and female threads of the spool. Use a surface cleaner such as chlorinated solvent on the threads and blow dry with compressed air. If necessary, use a 10–24 unc–2b tap to remove adhesive from the female threads.

8. Remove the capscrew (23), sealing washer (22) and o-ring (24) from the cap plate (29). Lift off the cap plate and remove the o-ring (20).
9. Hold the flats of the displacement rod (9) in a vise and use a spanner wrench in the pin holes of the piston (16) to screw it off the rod. Remove the trip rod (17) from the displacement rod.

### CAUTION

Be careful not to scratch the outside of the displacement rod.

10. Unscrew the nut (48) and remove the retainers (11) and spring (12) from the trip rod (17).
11. Slide the piston (16) off the trip rod (17). Remove the bearing (5), seal (6), and o-rings (7 and 8) from the piston.
12. Inspect the yoke (4) and trip rod (17) for damage. If either part requires replacement, slide the yoke into Repair Tool 189–305 and set the tool in a vise. See Fig. 2. Use a wrench on the flats of the trip rod and unscrew the rod from the yoke.
13. Pull the housing retainer (36) away from the bottom cylinder cap (35).
14. Remove the block packings (14 and 49), wiper (15), bearing (13), and o-ring (2) from the housing retainer and bottom cylinder cap.



# Service

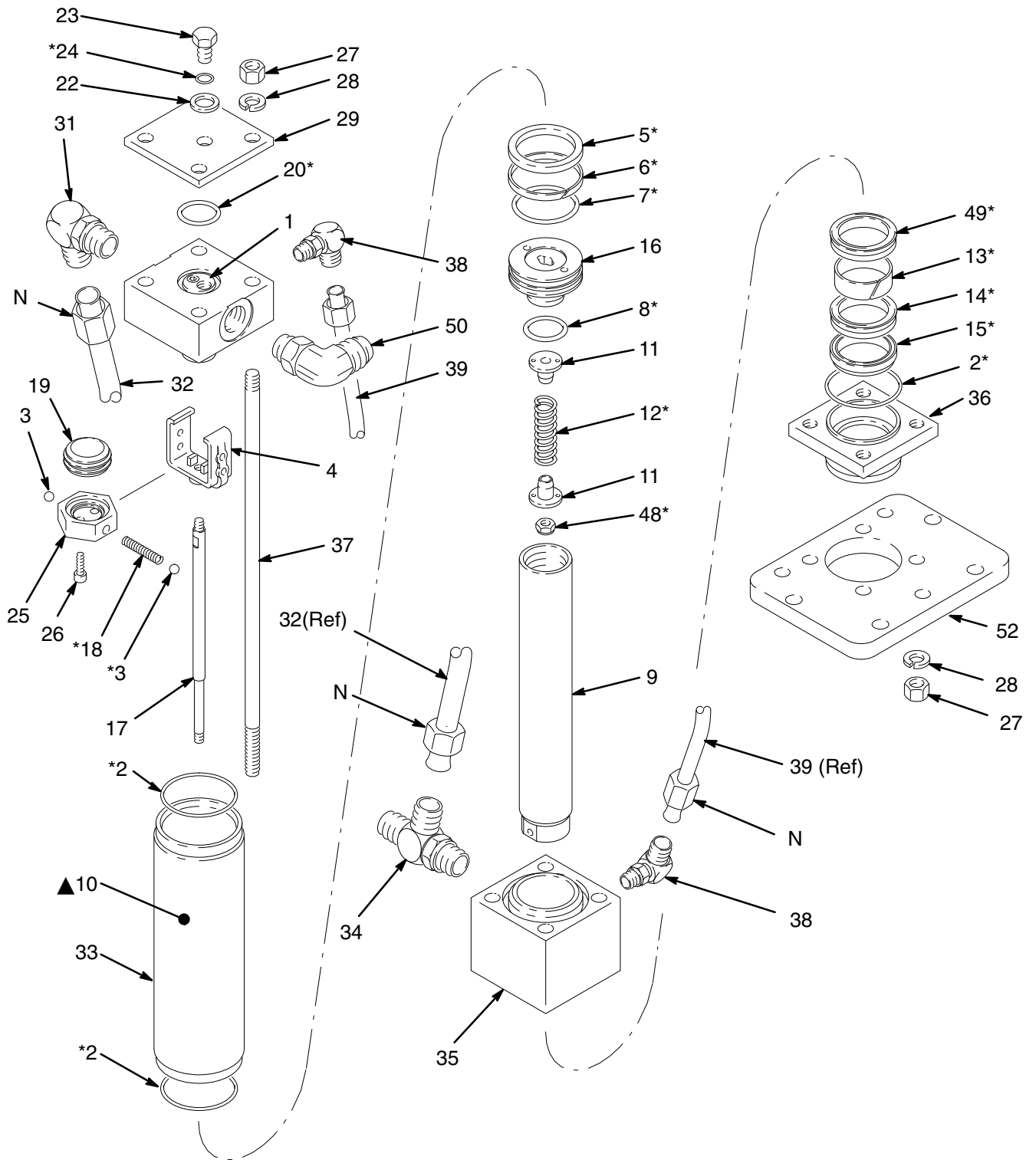

Fig. 1

06172A

# Service

## Hydraulic Motor Reassembly

1. Install the block packing (14\*) and wiper (15\*) in the housing retainer (36). *The spring of the block packing and the lips of the wiper must face up.* Install the o-ring (2\*) on the top surface of the retainer. See Fig. 2.
2. Install the bearing (13\*) and block packing (49\*) in the bottom cylinder cap (35). *The lips of the block packing must face up.*
3. Reassemble the housing retainer (36) and the bottom cylinder cap (35).
4. To reassemble the yoke (4) and trip rod (17), clean the threads with primer or chlorinated solvent and let dry for 3 to 4 minutes. Apply thread sealant to the female threads of the yoke. Slide the yoke into Repair Tool 189–305 and place the tool in a vise. Using a wrench on the flats of the trip rod, screw the rod into the yoke. Torque to 54 to 56 in-lb (6.1 to 6.3 N-m).
5. Install the bearing (5\*), o-ring (7\*), and seal (6\*) on the piston (16). Install the second o-ring (8\*) on the underside of the piston. Slide the piston onto the trip rod (17) so the wide end of the piston faces the yoke (4).
6. Install the retainers (11) and spring (12\*) on the trip rod (17). Thread the nut (48\*) onto the rod until it runs out of thread, so that it bottoms out on the shoulder of the rod. See the **Detail** in Fig. 2.
7. Hold the flats of the displacement rod (9) in a vise. Slide the trip rod (17) into the displacement rod. Use a spanner wrench in the pin holes of the piston (16) to screw it into the displacement rod. Torque to 30 to 40 ft-lb (41 to 54 N-m).
8. Install the o-ring (20\*) in the top cylinder cap (1), then install the cap plate (29), o-ring (24\*), sealing washer (22), and capscrew (23).
9. To reassemble the valve sleeve (19) and valve stop (25), slide the sleeve (19) onto the valve spool (S). (Either side of the sleeve can face up.) Apply primer to the threads of the screws (26) and let dry for 3 to 4 minutes. Apply 1 or 2 drops of thread sealant to the female threads of the spool (S). Install the stop (25) and torque the screws (26) to 42 to 45 in-lb (4.7 to 5.1 N-m).
10. To assemble the valve mechanism, use Repair Tool 189–305 as follows:
  - a. Slide the yoke (4) into the repair tool, as shown in the Detail in Fig. 2. Align the upper detent holes (H) of the yoke with the center line of the tool.
  - b. Insert the spring (18\*) and one ball (3\*) into the valve stop (25). Tilt the valve stop and start guiding it into the tool, making sure the ball is sliding into the rounded slot in the tool.
  - c. Place the second ball (3\*) at the other end of the spring (18\*) and push it in with your thumb while rotating the valve stop (25) until the spring is horizontal and the balls are in place. Continue holding this assembly together.
  - d. Align the curved ends of the yoke with the valve sleeve groove, then press the assemblies firmly together. Make sure the balls snap into the upper detent holes (H) of the yoke (4), and the curved ends of the yoke engage the valve sleeve (19) groove. To remove the tool, slide it over the trip rod (17).
11. Place the bottom cylinder cap (35) in a vise. Install the o-ring (2\*) in the cap. Set the cylinder (33) on the bottom cap.
12. Install the o-ring (2\*) in the top valve spool (1). Make sure the hydraulic fittings (31, 34, and 38) are oriented as shown in Fig. 1, then slide the displacement rod (9) and piston (16) into the cylinder (33) until it seats in the top cap.

### CAUTION

When inserting the piston into the cylinder, carefully guide the piston seal (6\*) and bearing (5\*) to prevent damage to these parts.

13. Install the tie rods (37). If the nuts and washers were removed, screw them onto the ends with short threads.
14. Remove the plugs from the fluid fittings (31, 34 and 38). Install the tubes (32, 39) and tighten the four fluid tube nuts (N).
15. Install the hydraulic motor on the pump as explained in the separate system manual.

# Service

- 1 Spring faces up.
- 2 Lips face up.
- 3 Apply thread sealant to female threads.
- 4 Torque to 54 to 56 in-lb (6.1 to 6.3 N-m).
- 5 Wide end faces yoke (4).
- 6 Apply primer to threads and let dry 3 to 4 minutes.
- 7 Apply 1 or 2 drops of thread sealant to female threads.
- 8 Torque to 42 to 45 in-lb (4.7 to 5.1 N-m).
- 9 Torque to 30 to 40 ft-lb (41 to 54 N-m).

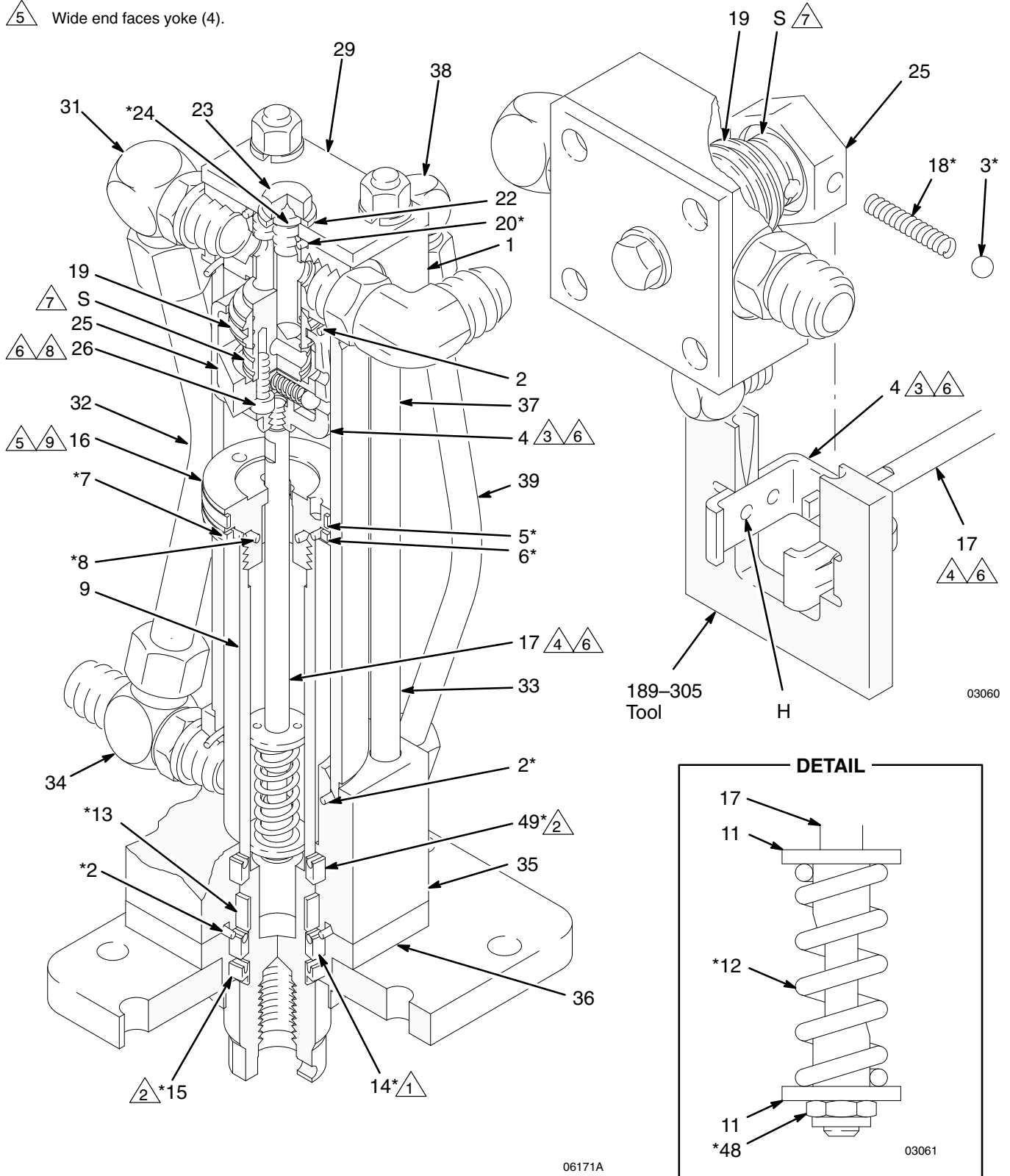
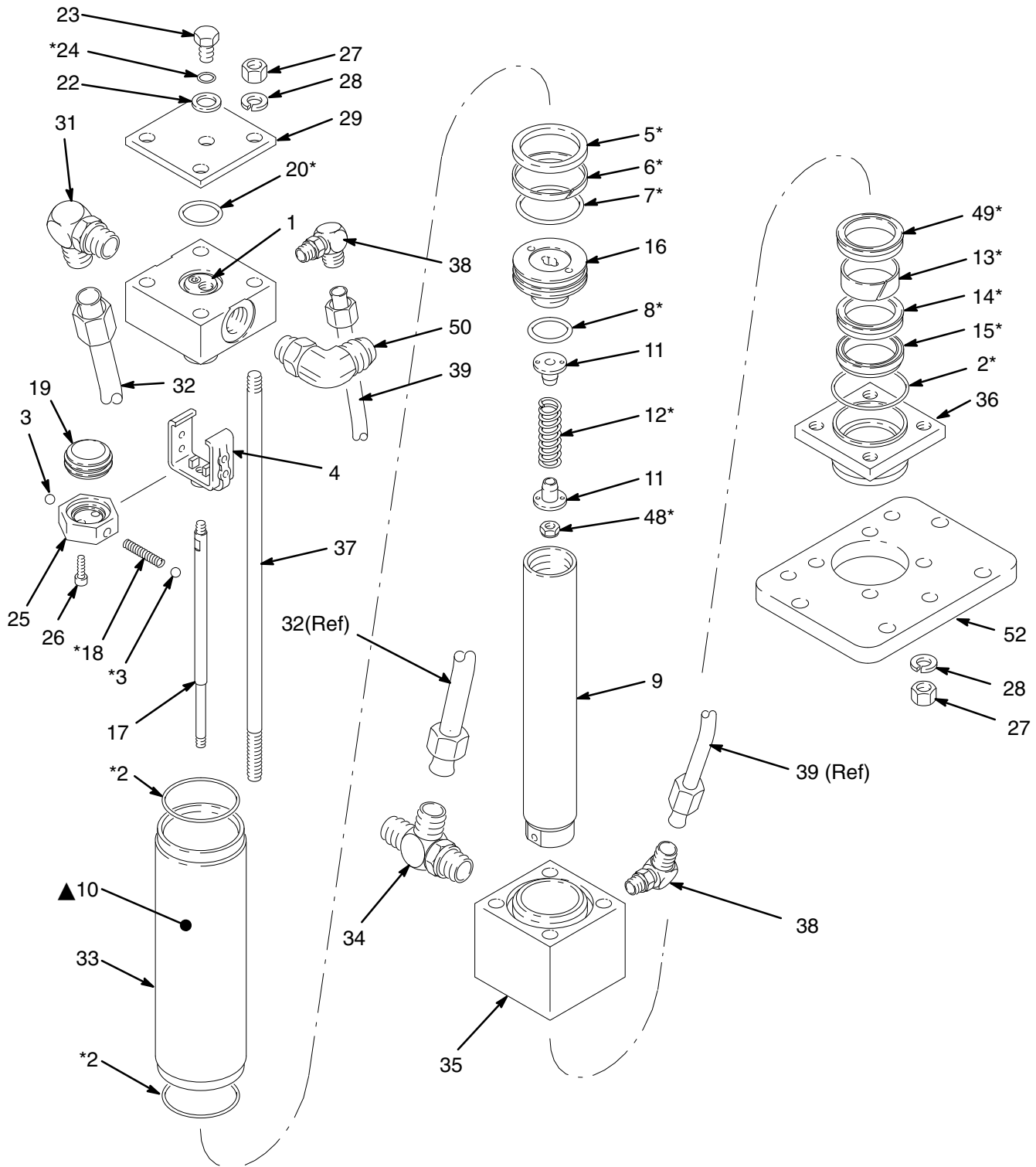

Fig. 2

# Viscount<sup>®</sup> I Hydraulic Motor Parts

Model 238-356, Series C



06172A

Fig. 3

# Viscount® I Hydraulic Motor Parts

## Model 238–356, Series C

Ref No.	Part No.	Description	Qty.	Ref No.	Part No.	Description	Qty.
1	236–594	VALVE, spool	1	27	106–292	NUT, hex; 3/8–24 unf–2b	8
2*	106–274	O-RING; buna-N	3	28	100–133	WASHER, lock; 3/8 in. size	8
3*	100–069	BALL; carbon steel	2	29	178–181	PLATE, cap	1
4	189–077	YOKE, valve	1	31	106–470	ELBOW, 90°; 3/4–16 unf–2a; fits 1/2 in. (13 mm) diameter tube	1
5*	178–207	BEARING, piston; bronze-filledPTFE	1	32	236–419	TUBE, inlet; w/3/4–16 unf–2b fittings	1
6*	178–226	SEAL, piston; glass-filledPTFE	1	33	178–229	CYLINDER	1
7*	108–014	O-RING; buna-N	1	34	107–197	TEE; 3/4–16 unf–2a	1
8*	105–765	O-RING; buna-N	1	35	189–073	CAP, cylinder, bottom	1
9	189–070	ROD, displacement	1	36	189–074	RETAINER, housing	1
10▲	179–885	LABEL, warning	1	37	189–075	ROD, tie	4
11	189–069	RETAINER, spring	2	38	110–792	ELBOW, 90°; 7/16–20 unf–2a x 9/16–18 unf–2a; fits 3/8 in. (10 mm) diameter tube	2
12*	178–189	SPRING, compression	1	39	236–420	TUBE, drain; w/9/16–18 unf–2b fittings	1
13*	112–342	BEARING, rod; bronze-filledPTFE	1	48*	114–231	NUT, hex, locking; w/nylon insert; #10–32 unf–3b	1
14*	112–340	PACKING, block; nitrile rubber	1	49*	112–561	PACKING, block; urethane	1
15*	112–341	WIPER, rod; nitrile rubber	1	50	113–585	ELBOW, 90°; 7/8–14 unf 2a x 3/4–16 unf–2a;	1
16	192–656	PISTON	1	52	191–216	PLATE, tie	1
17	192–657	ROD, trip	1				
18*	108–437	SPRING, compression	1				
19	189–072	SLEEVE, valve	1				
20*	104–093	O-RING; buna-N	1				
21	103–147	PLUG, pipe	1				
22	178–179	WASHER, sealing	1				
23	106–276	SCREW, cap, hex hd; 3/8–24 unf–2a; 0.625 (16 mm) long	1				
24*	155–685	O-RING; buna-N	1				
25	192–654	STOP, valve	1				
26	104–092	SCREW, cap, socket hd; 10–24 unrc–3a; 0.625 (16 mm) long	2				

\* These parts are included in Repair Kit 236–698, which may be purchased separately.

▲ Replacement Danger and Warning labels, tags and cards are available at no cost.

# Accessories

*Use Only Genuine Graco Parts and Accessories*

## Graco-Approved Hydraulic Fluid

Premium, ISO grade 46 petroleum-based hydraulic oil containing rust and oxidation inhibitors and anti-wear agents. 210°F (99°C) Flash Point.

**169–236**      5 gallon (20 liter)

**207–428**      1 gallon (3.8 liter)

## Assembly Tool 189–305

Required for reassembling the motor.

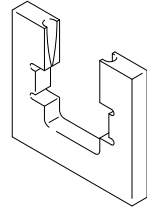

# Technical Data

Maximum hydraulic fluid input pressure .....	1500 psi (10 MPa, 102 bar)
Maximum hydraulic fluid input volume .....	3 gpm (11.3 liter/min)
Fluid consumption rate .....	6.5 ounces (0.195 liter) per cycle or 1 gallon per 19.5 cycles
Maximum water content of hydraulic fluid .....	1 percent
Maximum fluid temperature .....	130° F (54° C)
Effective piston area .....	1.48 sq in. (9.55 cm <sup>2</sup> )
Piston rod diameter .....	1 3/8 in. (34.9 mm)
Stroke .....	4 in. (101.6 mm)
Thrust at 1500 psi (10 MPa, 102 bar) .....	2220 lb (9875 N)
Weight .....	17.5 lb (7.93 Kg)

*Loctite® is a registered trademark of Loctite Corporation.*

*Perma-Loc® and Perma-Bond® are registered trademarks of Perma-Loc Company.*

# Manual Change Summary

Assembly Changed	Part Status	Ref. No.	Part No.	Name
238–356 to Series C	Old	11	192–655	Retainer
	New	11	189–069	Retainer



# Graco Standard Warranty

Graco warrants all equipment manufactured by Graco and bearing its name to be free from defects in material and workmanship on the date of sale by an authorized Graco distributor to the original purchaser for use. With the exception of any special, extended, or limited warranty published by Graco, Graco will, for a period of twelve months from the date of sale, repair or replace any part of the equipment determined by Graco to be defective. This warranty applies only when the equipment is installed, operated and maintained in accordance with Graco's written recommendations.

This warranty does not cover, and Graco shall not be liable for general wear and tear, or any malfunction, damage or wear caused by faulty installation, misapplication, abrasion, corrosion, inadequate or improper maintenance, negligence, accident, tampering, or substitution of non-Graco component parts. Nor shall Graco be liable for malfunction, damage or wear caused by the incompatibility of Graco equipment with structures, accessories, equipment or materials not supplied by Graco, or the improper design, manufacture, installation, operation or maintenance of structures, accessories, equipment or materials not supplied by Graco.

This warranty is conditioned upon the prepaid return of the equipment claimed to be defective to an authorized Graco distributor for verification of the claimed defect. If the claimed defect is verified, Graco will repair or replace free of charge any defective parts. The equipment will be returned to the original purchaser transportation prepaid. If inspection of the equipment does not disclose any defect in material or workmanship, repairs will be made at a reasonable charge, which charges may include the costs of parts, labor, and transportation.

**THIS WARRANTY IS EXCLUSIVE, AND IS IN LIEU OF ANY OTHER WARRANTIES, EXPRESS OR IMPLIED, INCLUDING BUT NOT LIMITED TO WARRANTY OF MERCHANTABILITY OR WARRANTY OF FITNESS FOR A PARTICULAR PURPOSE.**

Graco's sole obligation and buyer's sole remedy for any breach of warranty shall be as set forth above. The buyer agrees that no other remedy (including, but not limited to, incidental or consequential damages for lost profits, lost sales, injury to person or property, or any other incidental or consequential loss) shall be available. Any action for breach of warranty must be brought within two (2) years of the date of sale.

Graco makes no warranty, and disclaims all implied warranties of merchantability and fitness for a particular purpose in connection with accessories, equipment, materials or components sold but not manufactured by Graco. These items sold, but not manufactured by Graco (such as electric motors, switches, hose, etc.), are subject to the warranty, if any, of their manufacturer. Graco will provide purchaser with reasonable assistance in making any claim for breach of these warranties.

In no event will Graco be liable for indirect, incidental, special or consequential damages resulting from Graco supplying equipment hereunder, or the furnishing, performance, or use of any products or other goods sold hereto, whether due to a breach of contract, breach of warranty, the negligence of Graco, or otherwise.

## **FOR GRACO CANADA CUSTOMERS**

The parties acknowledge that they have required that the present document, as well as all documents, notices and legal proceedings entered into, given or instituted pursuant hereto or relating directly or indirectly hereto, be drawn up in English. Les parties reconnaissent avoir convenu que la rédaction du présente document sera en Anglais, ainsi que tous documents, avis et procédures judiciaires exécutés, donnés ou intentés à la suite de ou en rapport, directement ou indirectement, avec les procédures concernées.

# Graco Phone Number

**TO PLACE AN ORDER**, contact your Graco distributor, or call this number to identify the distributor closest to you:  
**1-800-367-4023 Toll Free.**

*All written and visual data contained in this document reflects the latest product information available at the time of publication.  
Graco reserves the right to make changes at any time without notice.*

**Sales Offices:** Minneapolis, Detroit, Los Angeles  
**Foreign Offices:** Belgium, Canada, England, Korea, France, Germany, Hong Kong, Japan

**GRACO INC. P.O. BOX 1441 MINNEAPOLIS, MN 55440-1441**

**<http://www.graco.com>**

PRINTED IN U.S.A. 308-618 April 1996, Revised December 1997