

Instructions–Parts List



AIR DRIVEN, 5 GAL. (19 LITER) SIZE

Agitators

306670J

ENG

**For mixing and maintaining suspension of industrial coatings.
For professional use only.**

100 psi (0.7 MPa, 7 bar) Maximum Working Pressure

Model 226086, Series F



Important Safety Instructions

Read all warnings and instructions in this manual.
Save these instructions.

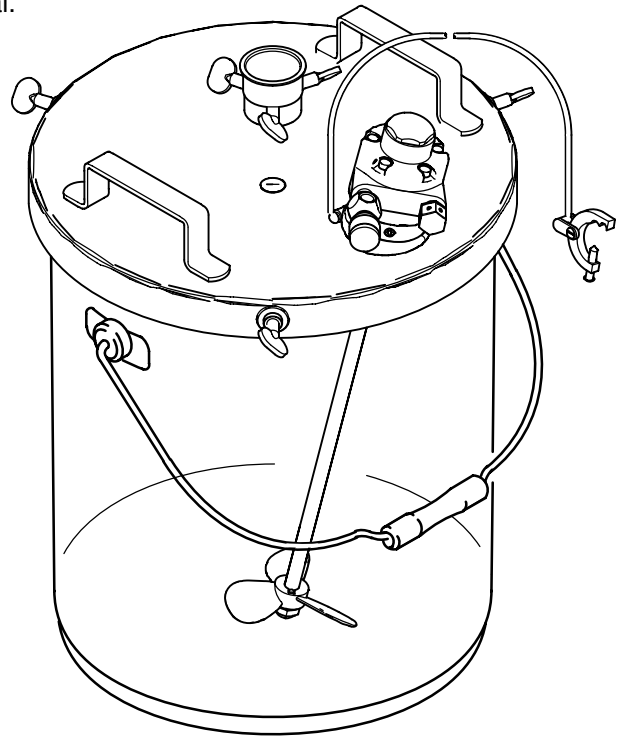

01174b

Table of Contents

Warnings	2
Installation	4
Operation	7
Service	7
Parts	8
Technical Data	9
Warranty	10
Graco Information	10



II 1/2 G T6
ITS03ATEX11251



HO03

Symbols

Warning Symbol



This symbol alerts you to the possibility of serious injury or death if you do not follow the instructions.

Caution Symbol



This symbol alerts you to the possibility of damage to or destruction of equipment if you do not follow the instructions.

WARNING



INSTRUCTIONS

EQUIPMENT MISUSE HAZARD

Equipment misuse can cause the equipment to rupture or malfunction and result in serious injury.

- This equipment is for professional use only.
- Read all instruction manuals, tags, and labels before operating the equipment.
- Use the equipment only for its intended purpose. If you are not sure, call Graco Technical Assistance at 1-800-543-0339.
- Do not alter or modify this equipment.
- Check equipment daily. Repair or replace worn or damaged parts immediately.
- Do not exceed the maximum working pressure of the lowest rated component in your system. This equipment has a **100 psi (7 bar) maximum working pressure**.
- Use fluids and solvents which are compatible with the equipment wetted parts. Refer to the **Technical Data** section of all equipment manuals. Read the fluid and solvent manufacturer's warnings.
- Always wear protective eyewear, gloves, clothing and respirator as recommended by the fluid and solvent manufacturer.
- Keep face away from the exhaust port.
- Comply with all applicable local, state, and national fire, electrical, and safety regulations.

WARNING



FIRE AND EXPLOSION HAZARD

Improper grounding, poor ventilation, open flames or sparks can cause a hazardous condition and result in a fire or explosion and serious injury.

- Ground the equipment and the object being sprayed. Refer to **Grounding** on page 6.
- If there is any static sparking or you feel an electric shock while using this equipment, **stop spraying immediately**. Do not use the equipment until you identify and correct the problem.
- Do not use 1,1,1-trichloroethane, methylene chloride, other halogenated hydrocarbon solvents or fluids containing such solvents in aluminum pumps. Such use could result in a serious chemical reaction, with the possibility of explosion.
- Do not use kerosene or other flammable solvents or combustible gases to flush the unit.
- Provide fresh air ventilation to avoid the buildup of flammable fumes from solvents or the fluid being sprayed.
- Keep the spray area free of debris, including solvent, rags, and gasoline.
- Before operating this equipment, electrically disconnect all equipment in the spray area.
- Before operating this equipment, extinguish all open flames or pilot lights in the spray area.
- Do not smoke in the spray area.
- Do not turn on or off any light switch in the spray area while spraying or while there are any fumes in the air.
- Do not operate a gasoline engine in the spray area.
- Keep a fire extinguisher in the work area.



MOVING PARTS HAZARD

Moving parts, such as the rotating blades of the agitator, can pinch or amputate your fingers or other body parts and can cause splashing in the eyes or on the skin.

- Keep clear of all moving parts when starting or operating the agitator.
- Always shut off the agitator and disconnect the air line before adjusting the angle of the agitator, removing the agitator from the drum or checking or repairing any part of the agitator.

Installation

WARNING



FIRE AND EXPLOSION HAZARD

Always maintain a minimum of 1 in. clearance between rotating agitator parts and container to prevent sparks from contact.

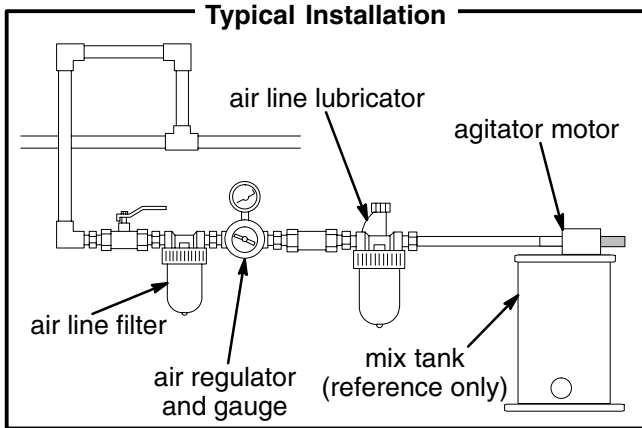

NOTE: The reference numbers and letters in parentheses in the text refer to the Parts Drawing and Fig. 1.

Air Requirements

For continuous use, the 1/4 HP air motor typically requires 2 cfm (0.06 m³/min) of air.

Preparing the Agitator for Use

1. Set the air motor (B) in the opening in the cover (1) as shown in Fig. 1. Secure with the two setscrews (5), using the allen wrench (4).
2. Slide the coupling (F) onto the shaft (A) of the air motor, then insert the agitator shaft (G) into the coupling. Secure the coupling with the two setscrews (E).
3. Close the needle valve (D). Install an air line quick disconnect to the air inlet. Order Part No. 208536 coupler and 169969 fitting, 1/8 npt(m). Then connect a properly sized air hose to the 1/8 npt(f) inlet of the valve.
4. Position the agitator and cover assembly on top of a 5 gal. (19 liter) pail of paint (P). Tighten the three thumbscrews (3).
5. Remove the cap gasket (6) and install a suction tube (M) in the largest port (Q) near the center of the cover. Adjust the suction tube so its end is about 1/4 in. (6 mm) above the bottom of the pail. Secure the tube in the port with three thumbscrews (3).

NOTE: The smaller port (N) is for use in a recirculation system.

6. Ground the agitator. See instructions on page 6.

Installation

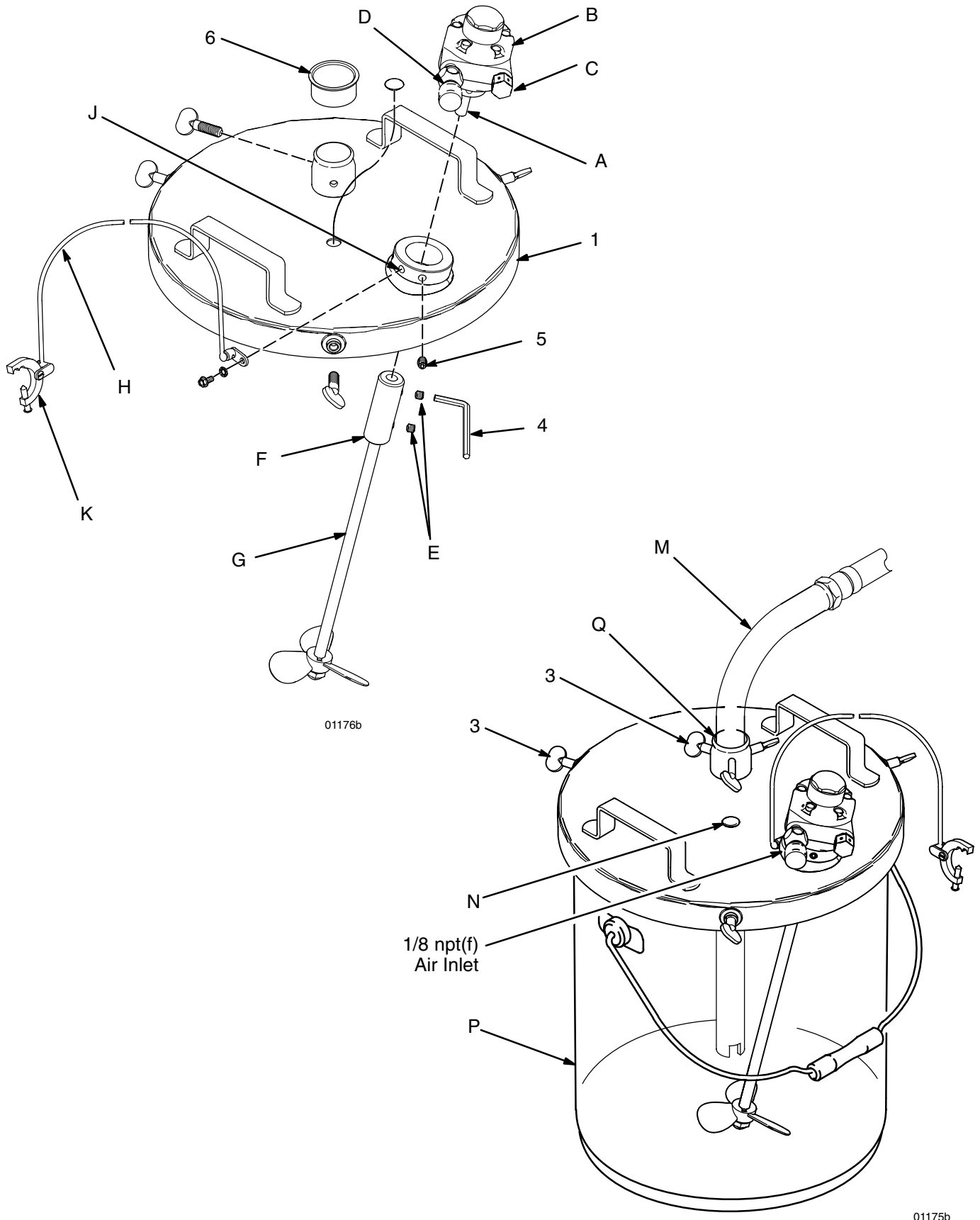

Fig. 1

Installation

Grounding

Proper grounding is an essential part of maintaining a safe system.

To reduce the risk of static sparking, all electrically conductive objects or devices in the spray area **must** be properly grounded. Check your local electrical code for detailed grounding instructions for your area and type of equipment.

To ground the agitator:

Connect the ground wire (H) to the grounding point (J) on the collar. See Fig. 2. Connect the ground clamp (K) to a true earth ground. Order Part No. 222011, Ground Wire and Clamp.

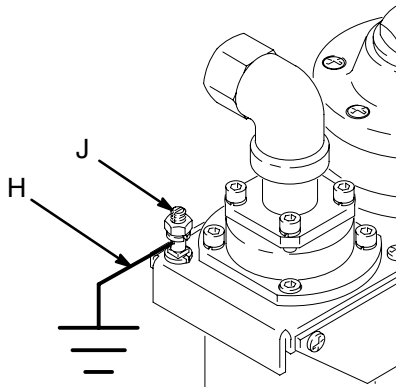

Fig. 2

03024

System Accessories

On the air line, install an air line filter to remove harmful dirt and moisture from the compressed air supply. Order Part No. 106148 filter, which is 3/8 npt(f) or 106149 filter, which is 1/2 npt(f).

⚠ CAUTION

Not lubricating the air motor will cause air motor failure.

Downstream from the filter, install an air line lubricator for automatic air motor lubrication. Set the lubricator feed rate at 1 drop of oil per minute for high speed or continuous duty usage. Do not overfeed oil or exhaust air may become contaminated. To manually lubricate the air motor, see **Lubricating the Air Motor** on page 7. To order a 3/8" npt air line lubricator, order Part No. 214847.

Operation

WARNING



MOVING PARTS HAZARD

To reduce the risk of serious injury, including cuts, amputation of fingers, and splashing in the eyes or on the skin:

- Always shut off the agitator and disconnect the air line before checking or repairing the agitator.
- Wear eye protection.

Regulate the agitator speed with the needle valve (D). See Fig. 1, page 5. Use the lowest agitator speed needed for thorough agitation of the paint. Excessive agitator speed may cause the paint to foam.

After a long period of standing, some paints will settle out and form a heavy cake on the bottom of the pail. To speed agitation in this case, loosen the thumb-screws holding the cover and slowly rotate the cover on the pail while the agitator is running.

Operate the agitator continuously while supplying paints or other fluids to the system.

Service

WARNING



FIRE AND EXPLOSION HAZARD

To prevent an explosive hazard, where injury and/or property damage can result:

- Do not operate this air motor with combustible gases.
- **Do not use kerosene or other flammable solvents to flush unit.**
- Keep face away from exhaust port. Foreign material exiting the air motor can be hazardous.

Gast® is a registered trademark of Gast Manufacturing.

Inhibisol® is a registered trademark of Penetone Corp.

Servicing

- If the unit requires more than installation of a service kit, it is usually quickest and easiest to send the unit to the Graco distributor for repair or replacement.
- If the vanes need replacing or foreign material is present in the motor chamber, an experienced mechanic may remove the end plate opposite the drive shaft end. *Do not pry with a screwdriver.* It will dent the surface of the plate and body, causing leaks. Use a puller tool, which will remove the end plate while maintaining the position of the shaft.
- New vanes should have the edges with cut corners (or the notched edges, if the vanes are reversible) pointing toward the bottom of the vane slot.

Flushing

If the motor is sluggish or inefficient, flush it with non-flammable solvent in a well ventilated area.

The recommended solvent for air motors and lubricated pumps is Gast® Flushing Solvent (Part No. AH255 or AH255A) or Inhibisol® Safety Solvent.

1. Disconnect the air line and muffler.
2. Add several teaspoons of solvent or spray the solvent directly into the motor.
3. Rotate the shaft by hand in both directions for a few minutes.
4. Reconnect the air line and slowly apply pressure until there is no trace of solvent in the exhaust air.
5. Re-lubricate the motor with a squirt of light-weight oil in the chamber.

Lubricating the Air Motor

CAUTION

Not lubricating the air motor will cause air motor failure.

If an air line lubricator is not installed, the air motor must be manually lubricated every 8 hours. Lubricate the agitator air motor by placing 10–20 drops of SAE #10 light oil in the motor's air inlet. Run the agitator for about 30 seconds.

Parts

Model 226086, Series F

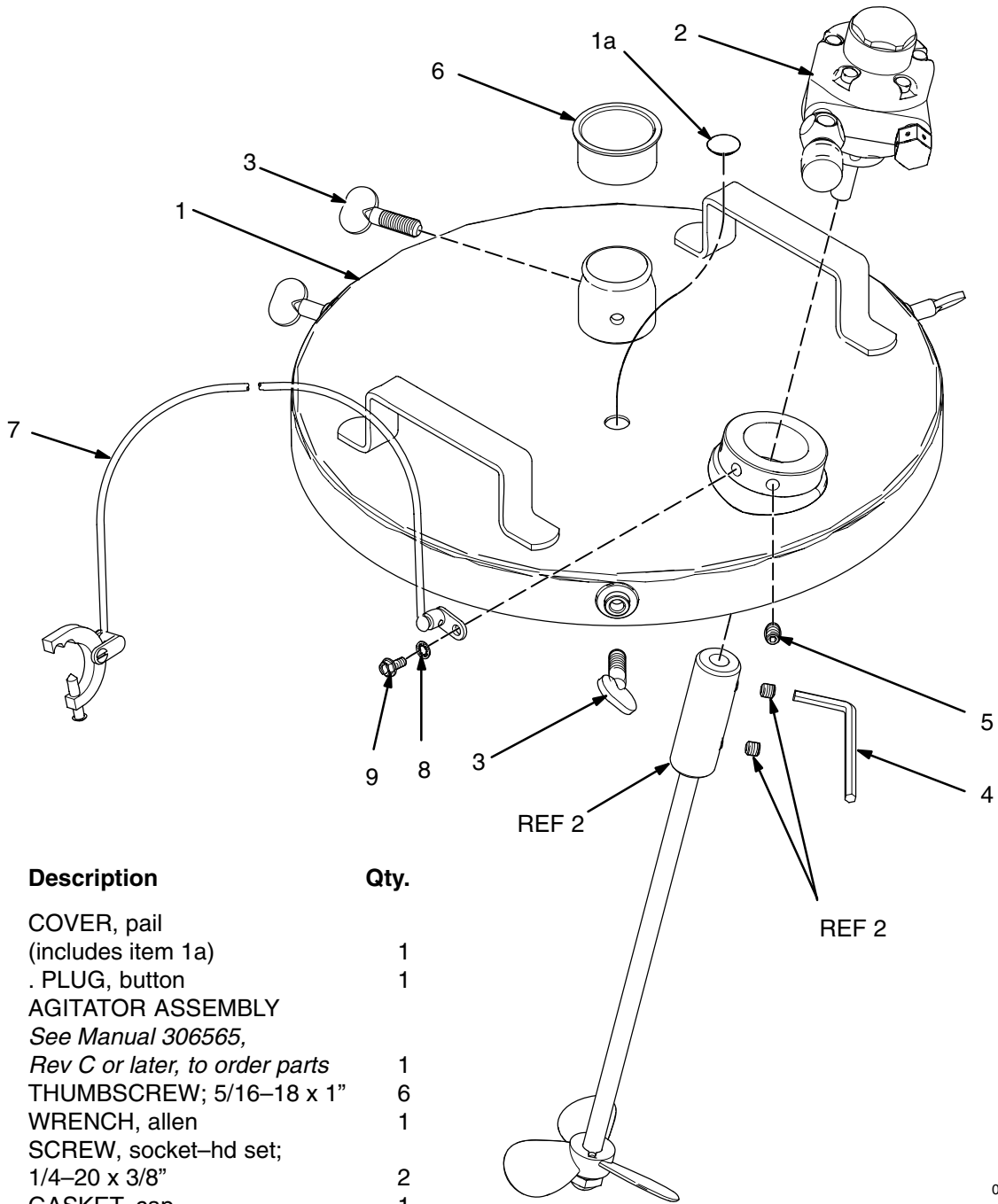

Ref. No.	Part No.	Description	Qty.
1	205342	COVER, pail (includes item 1a)	1
1a	110312	. PLUG, button	1
2	224571	AGITATOR ASSEMBLY <i>See Manual 306565, Rev C or later, to order parts</i>	1
3	100220	THUMBSCREW; 5/16-18 x 1"	6
4	101690	WRENCH, allen	1
5	101962	SCREW, socket-hd set; 1/4-20 x 3/8"	2
6	16H617	GASKET, cap	1
7	222011	GROUND WIRE ASSY	1
8	157021	WASHER, star	1
9	111593	SCREW, grounding	1

01176b

Technical Data

Maximum Working Pressure 100 psi (7 bar)
Motor power rating 1/4 HP (187 W)
Air Inlet Size 1/8 npt(f)
Air Consumption 2 cfm (0.06m³/min)
Wetted Parts Carbon Steel, Stainless Steel
Weight 5.73 lb (2.6 kg)

*Noise Level at 100 psi (7 bar) at normal load
at 800 rpm: Pressure 65.3 dB(A)
Power 74.2 dB(A)
*Noise Level at 100 psi (7 bar) at no load
at max rpm: Pressure 87.3 dB(A)
Power 96.2 dB(A)

*Tested to CAGI-PNEUROP-1969

Graco Standard Warranty

Graco warrants all equipment manufactured by Graco and bearing its name to be free from defects in material and workmanship on the date of sale to the original purchaser for use. With the exception of any special, extended, or limited warranty published by Graco, Graco will, for a period of twelve months from the date of sale, repair or replace any part of the equipment determined by Graco to be defective. This warranty applies only when the equipment is installed, operated and maintained in accordance with Graco's written recommendations.

This warranty does not cover, and Graco shall not be liable for general wear and tear, or any malfunction, damage or wear caused by faulty installation, misapplication, abrasion, corrosion, inadequate or improper maintenance, negligence, accident, tampering, or substitution of non-Graco component parts. Nor shall Graco be liable for malfunction, damage or wear caused by the incompatibility of Graco equipment with structures, accessories, equipment or materials not supplied by Graco, or the improper design, manufacture, installation, operation or maintenance of structures, accessories, equipment or materials not supplied by Graco.

This warranty is conditioned upon the prepaid return of the equipment claimed to be defective to an authorized Graco distributor for verification of the claimed defect. If the claimed defect is verified, Graco will repair or replace free of charge any defective parts. The equipment will be returned to the original purchaser transportation prepaid. If inspection of the equipment does not disclose any defect in material or workmanship, repairs will be made at a reasonable charge, which charges may include the costs of parts, labor, and transportation.

THIS WARRANTY IS EXCLUSIVE, AND IS IN LIEU OF ANY OTHER WARRANTIES, EXPRESS OR IMPLIED, INCLUDING BUT NOT LIMITED TO WARRANTY OF MERCHANTABILITY OR WARRANTY OF FITNESS FOR A PARTICULAR PURPOSE.

Graco's sole obligation and buyer's sole remedy for any breach of warranty shall be as set forth above. The buyer agrees that no other remedy (including, but not limited to, incidental or consequential damages for lost profits, lost sales, injury to person or property, or any other incidental or consequential loss) shall be available. Any action for breach of warranty must be brought within two (2) years of the date of sale.

Graco makes no warranty, and disclaims all implied warranties of merchantability and fitness for a particular purpose in connection with accessories, equipment, materials or components sold but not manufactured by Graco. These items sold, but not manufactured by Graco (such as electric motors, switches, hose, etc.), are subject to the warranty, if any, of their manufacturer. Graco will provide purchaser with reasonable assistance in making any claim for breach of these warranties.

In no event will Graco be liable for indirect, incidental, special or consequential damages resulting from Graco supplying equipment hereunder, or the furnishing, performance, or use of any products or other goods sold hereto, whether due to a breach of contract, breach of warranty, the negligence of Graco, or otherwise.

FOR GRACO CANADA CUSTOMERS

The parties acknowledge that they have required that the present document, as well as all documents, notices and legal proceedings entered into, given or instituted pursuant hereto or relating directly or indirectly hereto, be drawn up in English. Les parties reconnaissent avoir convenu que la rédaction du présente document sera en Anglais, ainsi que tous documents, avis et procédures judiciaires exécutés, donnés ou intentés à la suite de ou en rapport, directement ou indirectement, avec les procédures concernées.

Graco Information

For the latest information about Graco products, visit www.graco.com.

TO PLACE AN ORDER, contact your Graco distributor, or call one of the following numbers to identify the distributor closest to you:

1-800-328-0211 Toll Free

612-623-6921

612-378-3505 Fax

All written and visual data contained in this document reflects the latest product information available at the time of publication. Graco reserves the right to make changes at any time without notice.

Original instructions. This manual contains English. MM 306670

Graco Headquarters: Minneapolis

International Offices: Belgium, China, Japan, Korea

GRACO INC. P.O. BOX 1441 MINNEAPOLIS, MN 55440-1441

Copyright 1992, Graco Inc. is registered to ISO 9001

www.graco.com

Revised 04/2011