

ProDispense™

309301K

EN

Used to meter and dispense paints, coatings, solvents, water, and lubrication fluids.
For Professional Use Only.

Not approved for use in explosive atmospheres or hazardous locations.

Part No. 244561 Electronic Preset Dispense System



Important Safety Instructions

Read all warnings and instructions in this manual.
Save these instructions.
See page 4 for maximum working fluid pressure
and system component information.

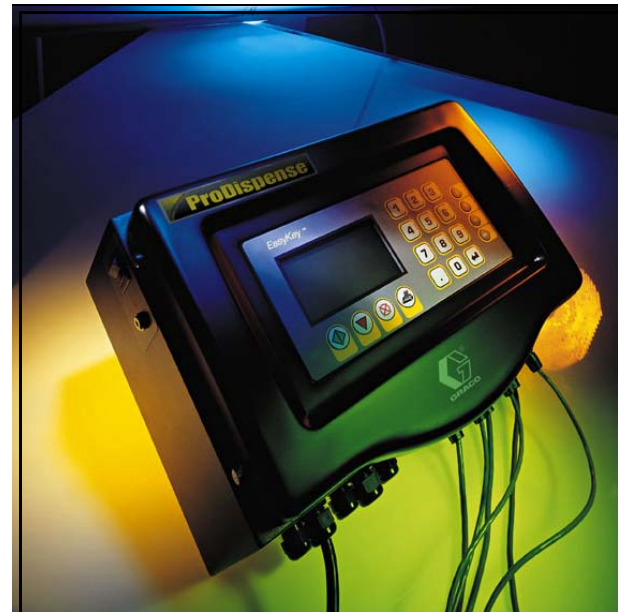

Intertek

Conforms to ANSI/UL
standard 3121-1
CAN/CSA C22.2 No 1010-1-92

See page 4 for listing details.

Table of Contents

ProDispense System Components	4
Conventions	5
WARNING	6
Overview	8
How the ProDispense System Works	8
Main Components	9
Installation	14
Install the Fluid Supplies	15
Mount the Fluid Panel(s)	16
Connect the Air and Fluid Lines	16
Install the Remote Operator Station	17
Mount the Controller	18
Connect the Cables and Power Cord	19
Ground the System	20
Check the Resistance	20
Connect a Printer (optional)	21
Connect to a PC or Alarm (optional)	21
Before Beginning Operation	22
Startup	23
Pressure Relief Procedure	24
Shutdown	24
Setup Mode	25
Screen Navigation	25
Dispense Mode	29
Screen Navigation	29
Operation Procedures	34
Loading Fluid Lines	34
Manual Dispense	34
Automatic Dispense	34
Purging Fluid	35
Emergency Stop	35
Troubleshooting	36

Service	37
Removing and Installing Controller	37
Replacing Display Board	39
Replacing Display	40
Replacing Membrane	40
Replacing Main Board	41
Replacing Power Supply	42
Replacing Fluid Panel Junction Box	43
Servicing Fluid Panel 244599	46
Servicing Fluid Panel 244600	48
Servicing Fluid Panel 244601 and 246837	50
Servicing Fluid Panel 246838	52
Servicing Fluid Panel 246839	54
Wiring Charts	55
Parts	62
Part No. 244561, Controller	62
Part No. 244599, Fluid Panel	64
Part No. 244600, Fluid Panel (not ETL listed)	65
Part No. 244601, Fluid Panel	66
Part No. 246837, Fluid Panel	67
Part No. 246838, Fluid Panel	68
Part No. 246839, Fluid Panel	69
Notes	70
Technical Data	71
Accessories and Kits	73
Graco Standard Warranty	74
Graco Information	74

ProDispense System Components

Follow the instructions in this manual (309301) and refer to the component manuals for additional warning, operation, service, and parts information. See the table below for:

- maximum working pressure of the fluid panels
- component part numbers and manual numbers
- parts list page numbers

Fluid Panels Part No.	244599 Oil/Lubricant	* 244600 Water/Antifreeze	244601 Grease/Paint
Maximum Working Pressure	1500 psi (10 MPa, 103 bar)	250 psi (1.7 MPa, 17 bar)	3000 psi (21 MPa, 207 bar)
Fluid Meter Part No.	238618	513891	239716
Manual No.	308245	—	308778
Dispense Valve Part No.	—	—	205612
Manual No.	—	—	306715
Parts List Page No.	64	65	66
Fluid Panels Part No.	246837 Grease/Paint	246838 Meterless	246839 Sealants
Maximum Working Pressure	3000 psi (21 MPa, 207 bar)	3000 psi (21 MPa, 207 bar)	3000 psi (21 MPa, 207 bar)
Fluid Meter Part No.	244292	—	246190
Manual No.	308778	—	309834
Dispense Valve Part No.	205612	205612	205612
Manual No.	306715	306715	306715
Parts List Page No.	69	70	71

ProDispense Controller Part No. 244561

Parts List Page No. 62

Remote Operator Station Part No. 116669

* The fluid meter used on Part No. 244600 is not ETL listed.

Conventions

The following conventions are used in this manual to help guide you through the information.

	Warning Symbols		
	The warning symbol alerts you to the possibility of serious injury or death if you do not follow the instructions.		
			Symbols, such as fire, explosion, or electric shock hazard (shown at left), alert you to the specific hazard. Read the main Warnings on pages 6-7 for detailed information about the hazard indicated.
	Caution Symbol		
	The caution symbol alerts you to the possibility of equipment or property damage or to operation errors if you do not follow the instructions.		

Note Symbol

The note symbol is used to call your attention to additional helpful information.



Amount *20 qts*

Recipe# 



ID# 

1. Enter the ID number.

①

- *Italicized text* in a screen diagram indicates the text may vary according to how the system parameters have been configured. For example, the units of measure shown in the manual may be *qts* (quarts). The units you see on your screen may be pounds, kilograms, quarts, gallons, or liters.
- A shaded box  is used to indicate a value/field that can be edited on the controller screen.
- A circled number ① in a screen diagram relates a field on the screen to a step in a procedure.
- Numbers and letters in parentheses in the text, such as (A) or (7), refer to reference numbers and letters in the figures.
- When you need to press a key during a procedure, the key is indicated by an icon as shown in the following example: Press Start  to begin the dispense.

! WARNING

	<p>FIRE, EXPLOSION, AND ELECTRIC SHOCK HAZARD</p> <p>Improper grounding, poor ventilation, open flames or sparks can cause a hazardous condition and result in fire, explosion or electric shock.</p> <ul style="list-style-type: none"> • Installation and service of electrical components must be completed by a qualified electrician. • Do not install the ProDispense controller, fluid panels, or remote operator station in a hazardous location. • Ground the equipment. See Ground the System, page 20. • If there is any static sparking while using equipment, stop dispensing immediately. Identify and correct the problem. • Provide fresh air ventilation to avoid buildup of flammable fumes. • Eliminate all ignition sources, such as cigarettes. • Avoid spilling fluids onto electrical components. • Turn off the ProDispense controller power switch before servicing equipment.
	<p>TOXIC FLUID HAZARD</p> <p>Hazardous fluid or toxic fumes can cause serious injury or death if splashed in the eyes or on the skin, inhaled, or swallowed.</p> <ul style="list-style-type: none"> • Always wear protective eyewear, gloves, clothing and respirator as recommended by the fluid and solvent manufacturer. • Know the specific hazards of the fluid you are using. • Store hazardous fluid in an approved container. Dispose of hazardous fluid according to all local, state and national guidelines.
	<p>EQUIPMENT MISUSE HAZARD</p> <p>Equipment misuse can cause the equipment to rupture or malfunction and result in serious injury.</p> <ul style="list-style-type: none"> • This equipment is for professional use only. • Read all instruction manuals, tags, and labels before operating the equipment. • Use the equipment only for its intended purpose. If you are not sure, call your Graco distributor. • Do not alter or modify this equipment. • Check equipment daily. Repair or replace worn or damaged parts immediately. • Do not exceed the maximum working pressure stated on the equipment or in the Technical Data, page 71. • Use fluids and solvents which are compatible with the equipment wetted parts. Refer to the Technical Data in all equipment manuals and the fluid manufacturer warnings. • Route hoses away from traffic areas, sharp edges, moving parts, and hot surfaces. Do not expose Graco hoses to temperatures above 180° F (82° C) or below -40° F (-40° C). • Comply with all applicable local, state, and national fire, electrical, and safety regulations.

WARNING



HIGH PRESSURE FLUID HAZARD/SKIN INJECTION HAZARD

Fluid Panels 244599 and 244601 can be operated at very high fluid pressure (see page 4). High pressure spray from dispense valves, hoses, or ruptured components can inject fluid into your body and cause an extremely serious injury, including the need for amputation. Splashing fluid in the eyes or on the skin can also cause a serious injury.

The following precautions should be taken for high pressure fluid dispensing:

- Fluid injected into the skin might look like just a cut, but it is a serious injury. **Get immediate surgical treatment.**
- Do not place a rag over the end of the nozzle and “blow back” fluid to clear the nozzle.
- Follow the additional precautions under **LOW PRESSURE FLUID HAZARD.**

LOW PRESSURE FLUID HAZARD

Fluid Panel 244600 is for low pressure use only (see page 4). Fluid coming from the dispense valves, leaks or ruptured components can splash in the eyes or on the skin and cause serious injury.

The following precautions should be taken for either high or low pressure fluid dispensing:

- Wear protective eyewear.
- Do not put your hand or fingers over the valve nozzle or hose.
- Do not point the dispense valve or hose at anyone or at any part of the body.
- Do not stop or deflect leaks with your hand, body, glove or rag.
- Follow the **Pressure Relief Procedure** on page 24 before cleaning, checking, or servicing the equipment or installing or cleaning the dispense valve nozzle.
- Tighten all fluid connections before operating the equipment.
- Check the hoses, tubes, and couplings daily. Replace worn, damaged, or loose parts immediately.

Overview

How the ProDispense System Works

Usage

The ProDispense system enables you to accurately dispense preset amounts of up to three different fluids or to manually dispense fluid as desired. The fluid meters provide accurate fluid flow readings to the controller. Controller totalizers use the meter flow readings to calculate fluid volume and usage and display the information on the screen. The controller can store the parameters for up to 250 recipe dispenses.

Fluid Supply

The ProDispense system can dispense fluids supplied from pressure tanks or feed pumps. Each fluid is supplied separately to the ProDispense fluid panels.

Choice of Recipe Dispense or Fluid Dispense

You can choose Fluid Dispense mode to individually enter a fluid preset volume and dispense the fluid. Or you can choose Recipe Dispense mode to dispense a preset recipe. A recipe allows you to select or set up to three preset fluid volumes simultaneously.

Regardless of which dispense mode you choose, a dispense tolerance must be entered for each fluid. The controller monitors the Target and Actual dispense values and reports an error if the tolerance is not maintained.

Main Components

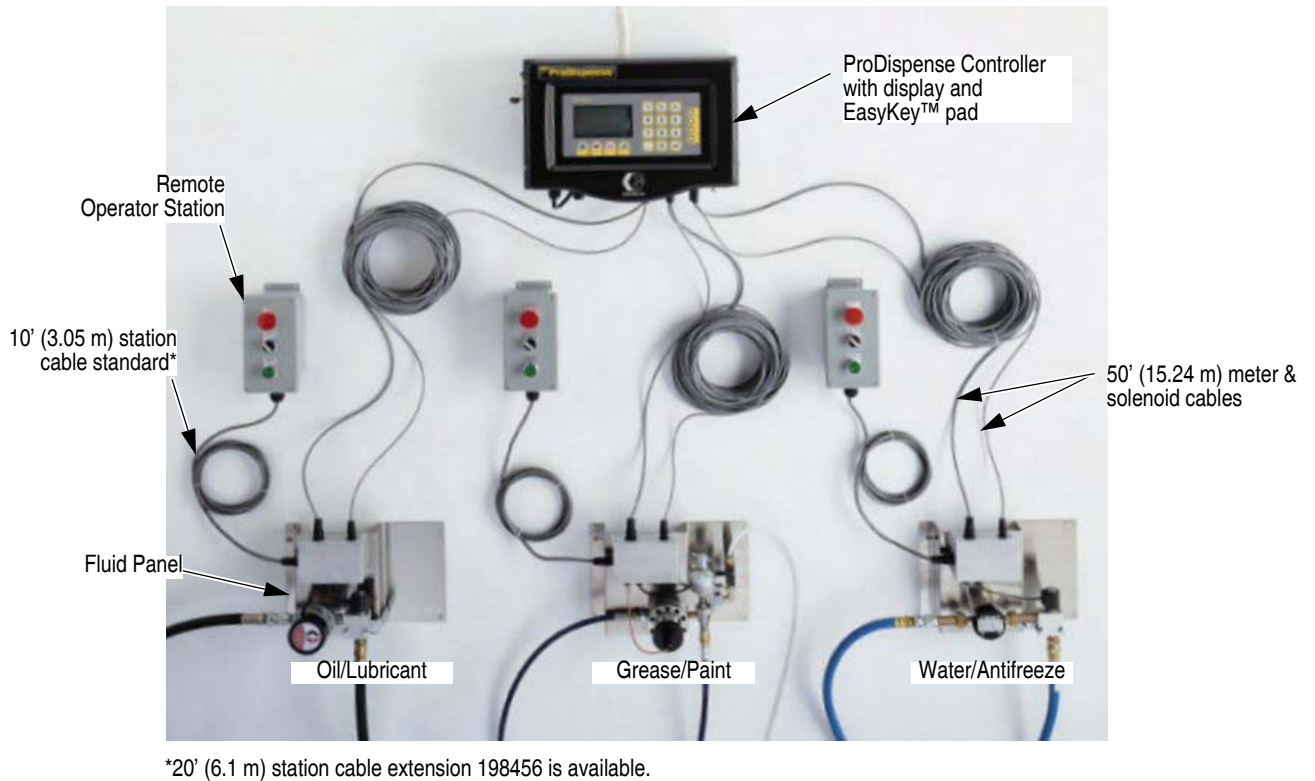

FIG. 1

ProDispense Controller

The controller is used to setup the ProDispense system, fluids, and recipes, calibrate the meters, and select a recipe or preset a dispense. The controller totalizers enable you to view fluid dispense information and print the following reports:

- Alarm history report
- Totals report
- Configuration Setup report
- Fluid Setup report
- Recipe Setup report
- Run report

Display and EasyKey™ Pad

The EasyKey™ pad is the operator interface for the ProDispense system. The keypad consists of number keys, enter key, scrolling (arrow) keys, and operation (start, stop, clear, and print) keys.

The graphic LCD screen displays system status, setup information, and operation options that can be selected using the keypad.

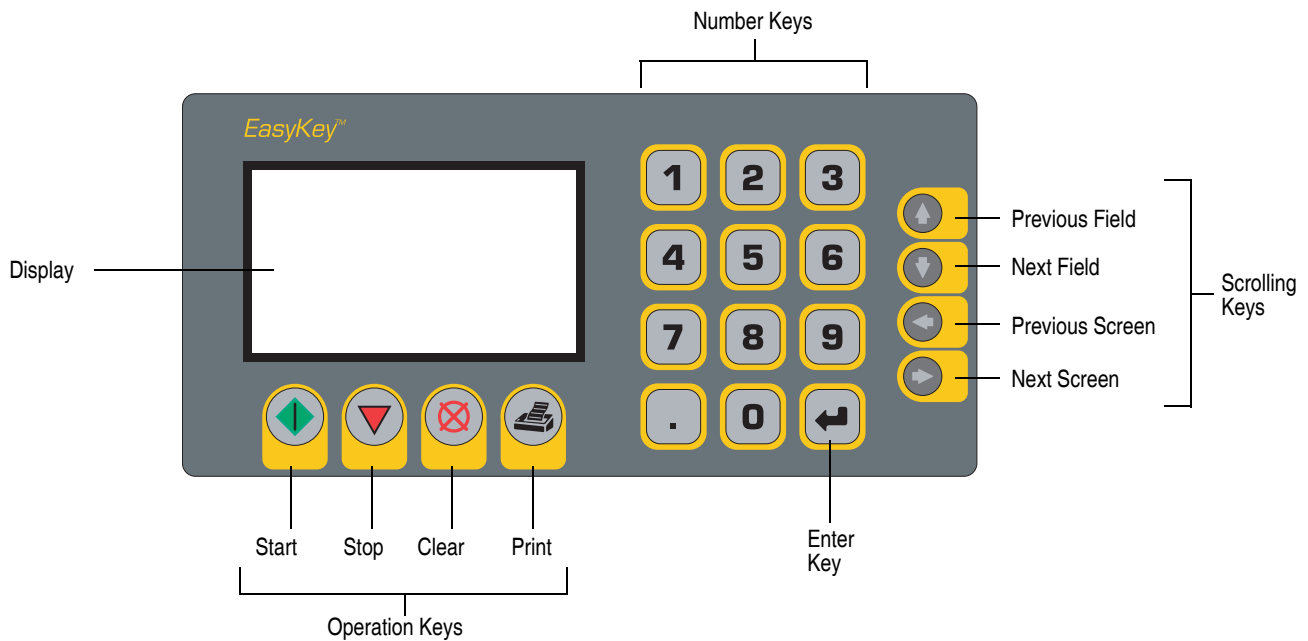

FIG. 2

1 **Number Keys** — type in setup or operation data.

Enter Key — press to accept and enter data.

If you press a scrolling key without pressing Enter, the cursor will move to the next field and the information you typed will reset back to the previous data.

Scrolling Keys — press the up or down arrows to move between fields on the screen. Use the left or right arrows to move between screens.



Operation Keys — use to operate the ProDispense system functions.

Start—press to start the current recipe dispense.



Stop—press to stop the current process.



Clear—press to clear an entry in an input field.



Print—press to print a report.



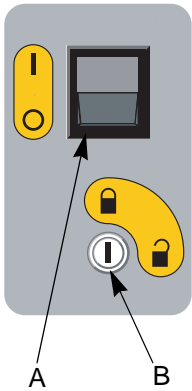



Power Switch (A)

On = **I** Off = **O**.

(On side of controller)

Operation Mode Switch (B) and Key (C)

The position of the switch (B) determines which mode of operation you are in:

Dispense Mode  or Setup Mode . A key (C) supplied with the ProDispense system is inserted into the switch and turned to change operation modes. The key cannot be removed while the system is in Setup Mode.

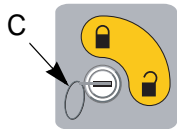

Dispense Mode  is used to dispense a recipe, fluid, check fluid totals, and to view the alarms log.

Setup Mode  is used to configure the system, fluid, and recipe parameters, and to calibrate the meters.

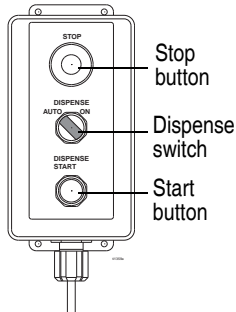

Remote Operator Stations

A cable connects the operator station to the fluid panel junction box. A separate operator station is needed for each fluid panel installed on the system. The dispense switch can be set to dispense automatically (AUTO) or manually (ON).

If set to AUTO, the fluid panel will dispense when a recipe or fluid dispense is selected with the controller and the start button is pressed either on the controller or the operator station. The dispense will stop when the preset amount is reached or when the stop button is pressed on either the controller or the operator station.

If set to ON, the fluid panel will begin dispensing immediately or when the dispense valve is triggered. The dispense is stopped by releasing the trigger or turning the dispense switch to AUTO or pressing the STOP button on the operator station.

Fluid Panels

There are six types of fluid panels available:

- 244599 — Oil and Lubricant Fluid Panel
- 244600 — Water and Antifreeze Fluid Panel (not ETL listed)
- 244601 — Grease and Paint Fluid Panel
- 246837 — Grease and Paint Fluid Panel
- 246838 — Meterless Fluid Panel (meter supplied by user)
- 246839 — Grease and Paint Fluid Panel

There are three cable connections on the fluid panel junction box for connecting:

- operator station to the solenoid connection
- controller to solenoid connection
- controller to meter connection

Signals from the controller and operator station communicate to the fluid panel(s) when to start and stop dispensing. Signals from the fluid panel's fluid meter communicate to the controller how much fluid has been dispensed.

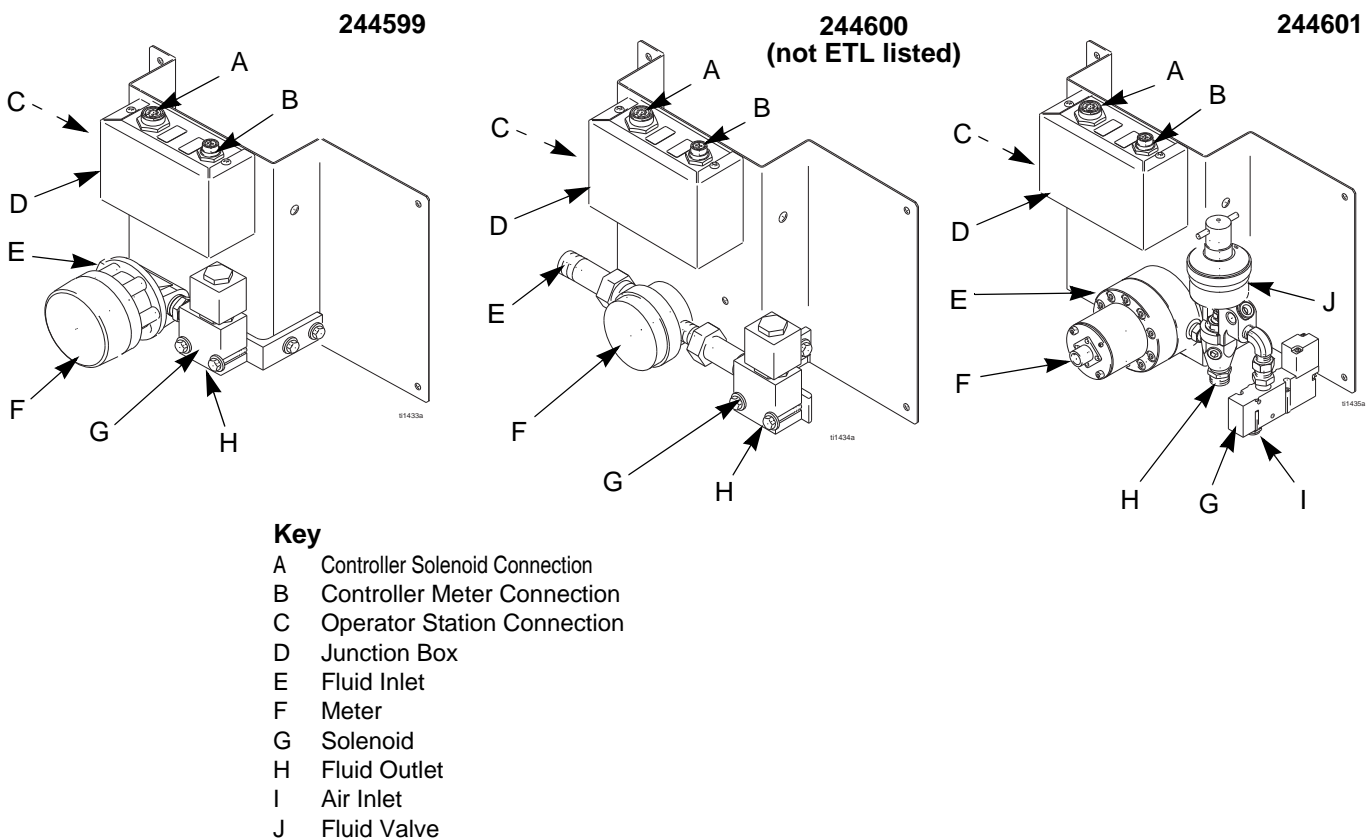
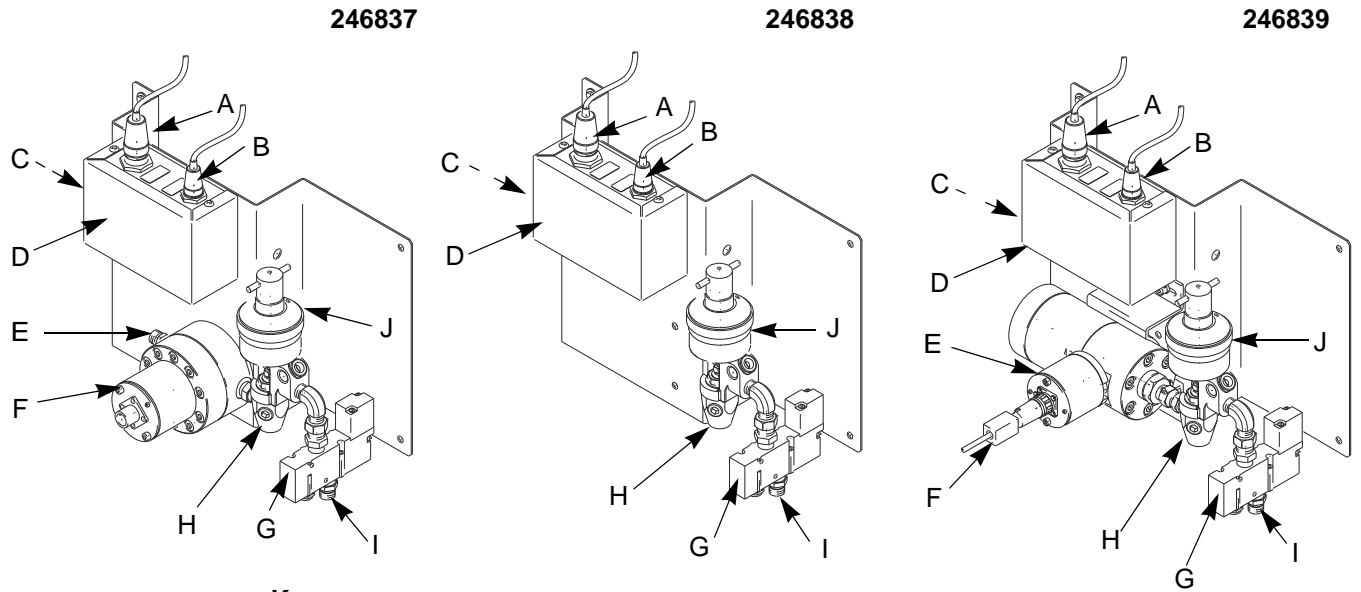

FIG. 3



- Key**
- A Controller Solenoid Connection
 - B Controller Meter Connection
 - C Operator Station Connection
 - D Junction Box
 - E Fluid Inlet
 - F Meter
 - G Solenoid
 - H Fluid Outlet
 - I Air Inlet
 - J Fluid Valve

FIG. 4

Installation



NOTE: Do not install or service this equipment unless you are trained and qualified.

NOTE: Do not install the ProDispense controller, fluid panels, or remote operator station in a hazardous location.

- FIG. 5 is not an actual system design. Contact your Graco distributor for assistance in designing your system.
- See detailed installation instructions, beginning on page 18.
- Be sure all accessories are adequately sized and pressure rated to meet the system requirements.
- Be sure mounted surfaces and fasteners can support the weight of the equipment; hose, tubing and cable attachments; and fluid.

Key for FIG. 5

- 1 ProDispense Controller with EasyKey™ Pad
- 2 Remote Operator Station
- 3 Oil/Lubricant Fluid Panel (244599)
- 4 Water/Antifreeze Fluid Panel (244600; not ETL listed)
- 5 Grease/Paint Fluid Panel (244601)
- 6 Fluid Supply Pump
- 7 Fluid Supply
- 8 Air Supply Line
- 9 Dispense Valve
- 10 Ground Wire to true earth ground
- 11 Fluid Supply Line
- 12 Fluid Dispense Line
- 13 Fluid Shutoff Valve
- 14 Bleed-type Air Shutoff Valve
- 15 Optional Printer

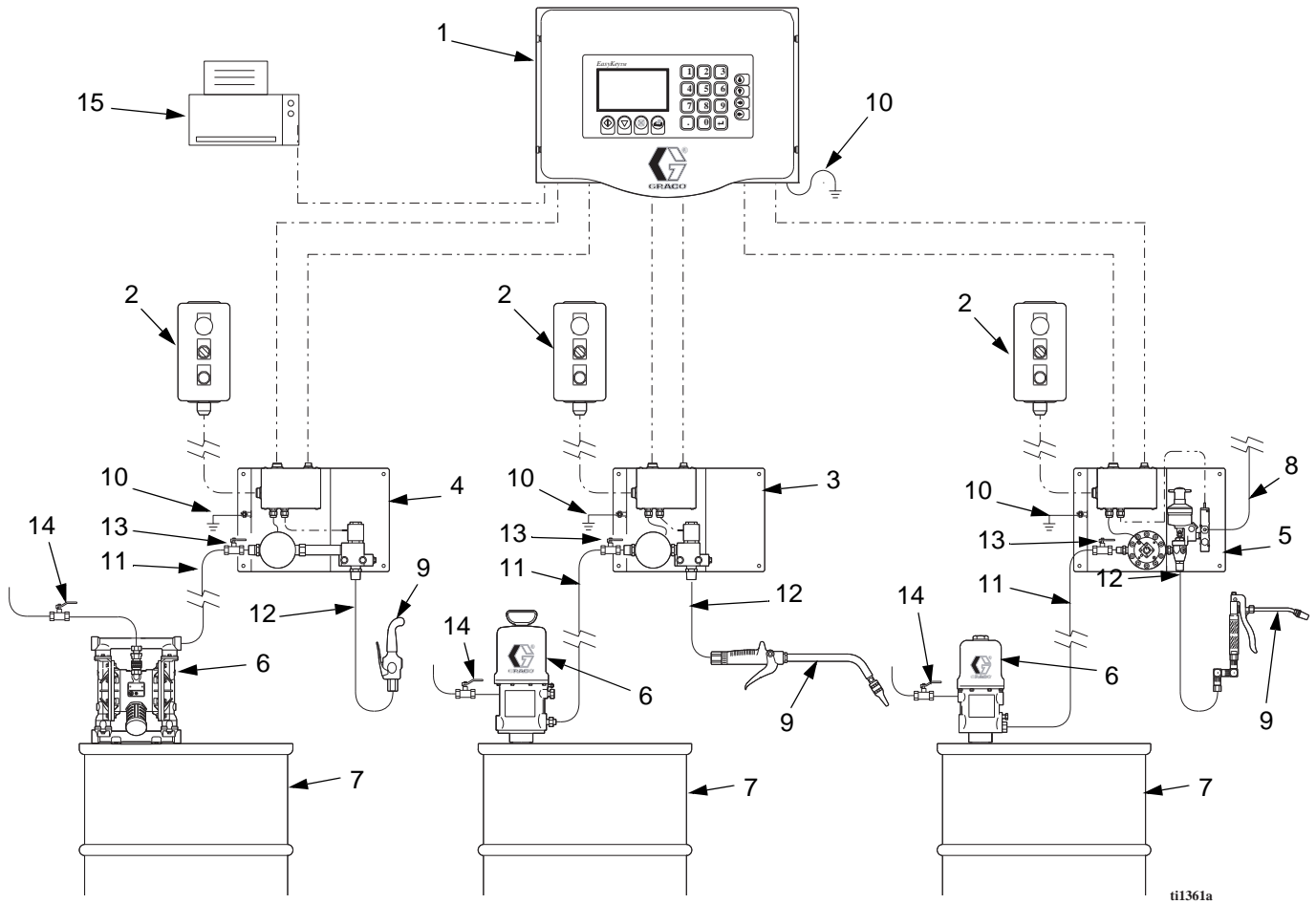

FIG. 5 ProDispense System - Typical Installation

Install the Fluid Supplies



For maintenance and safety, you must install:

- a fluid shutoff valve between each fluid supply line and the ProDispense fluid panel.
- a bleed-type air shutoff valve on the air supply line to the fluid supplies.

The ProDispense fluid panels can be supplied by pressure tanks, pail or drum pumps, or central recirculating lines.

The fluid supply must be free of pressure spikes, commonly caused by a pump stroke changeover. If necessary, install pressure regulators or a surge tank on the fluid supply outlets. Note that this will also reduce the fluid supply pressure.

Mount the Fluid Panel(s)

Mount the fluid panel(s) on a flat, sturdy surface. Install 1/4" or M6 fasteners in the four 0.28" mounting holes (C1) and secure the fluid panel (C) to the mounting surface. Connect a ground wire (G) as instructed on page 20.

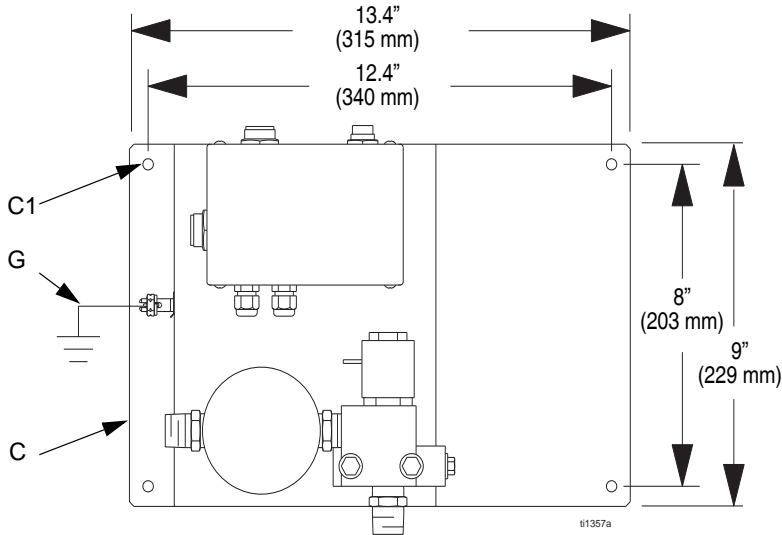

FIG. 6

Connect the Air and Fluid Lines

Fluid Panel 244599 and 244600

Connect the fluid supply line (11) to the 1/2" npt(f) meter inlet. See FIG. 5. Connect a fluid dispense line (12) to the 1/2" npt(f) solenoid outlet. Connect the other end to the dispense valve (9).

Fluid Panel 244601 and 246837

Connect an air supply line (8) to the 1/4" npt(f) solenoid valve port. The air supply must be filtered to 10 micron to lengthen solenoid valve life.

Connect the fluid supply line (11) to the 1/4" npt(f) meter inlet. Connect a fluid dispense line (12) to the 3/8" npt(m) outlet of the dispense valve on the fluid panel. Connect the other end to the dispense valve (9).

Fluid Panel 246838

Connect an air supply line (8) to the 1/4" npt(f) solenoid valve port. The air supply must be filtered to 10 micron to lengthen solenoid valve life.

Connect the fluid supply line (11) to the meter inlet. Connect a fluid dispense line (12) to the 3/8" npt(m) outlet of the dispense valve on the fluid panel. Connect the other end to the dispense valve (9).

Fluid Panel 246839

Connect an air supply line (8) to the 1/4" npt(f) solenoid valve port. The air supply must be filtered to 10 micron to lengthen solenoid valve life.

Connect the fluid supply line (11) to the 3/4" npt(f) meter inlet. Connect a fluid dispense line (12) to the 3/8" npt(m) outlet of the dispense valve on the fluid panel. Connect the other end to the dispense valve (9).

Install the Remote Operator Station

Mount the operator station (D) in a convenient location for the operator. Secure it with No. 10 or M5 fasteners through the four 0.22" mounting holes (D1). Connect the cable (D2) to the fluid panel junction box connector marked **C**.

NOTE: 20 ft. (6.1 m) station cable extension 198456 is available.

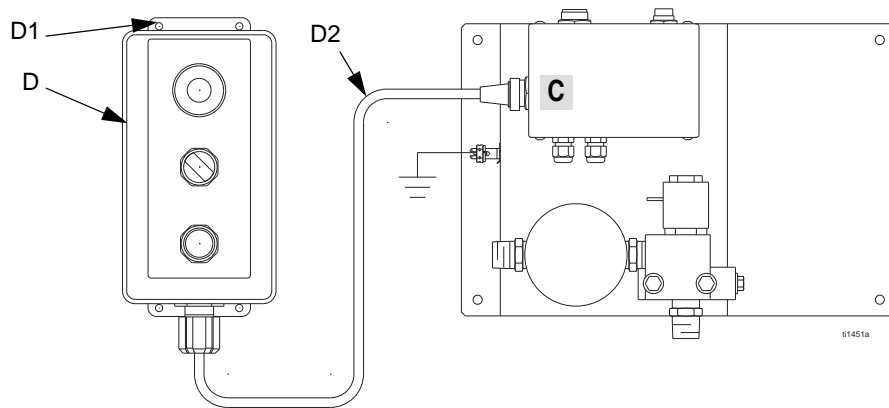

FIG. 7

Mount the Controller

Mount the controller on a flat, sturdy surface as instructed below.

1. Loosen the four screws (A1), disconnect the two cables (A2, A3) and remove the controller cover (A).
2. Install 0.44" or M11 fasteners in the four 0.51" mounting knockouts (B1) and secure the controller (B) to the mounting surface.
3. Reconnect the cables (A2, A3).
4. Install the controller cover (A) and secure it with the screws (A1).

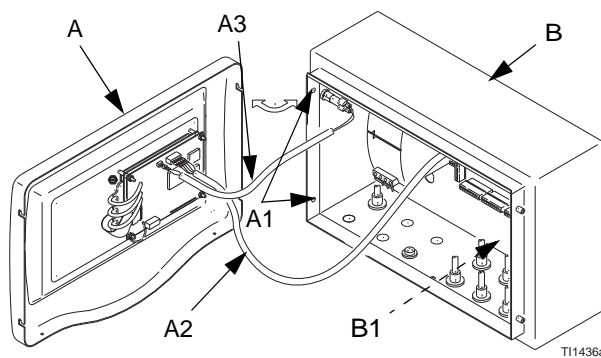

FIG. 8

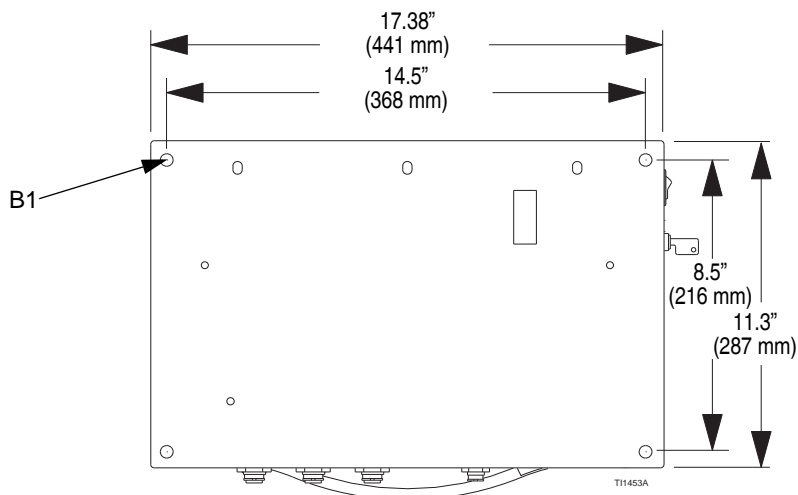

FIG. 9

Connect the Cables and Power Cord

On the bottom of the controller, there are meter and solenoid cable connectors for three Fluid panels. The row of connectors marked **1A**, **2A**, and **3A** are for solenoid cable connections. The row of connectors marked **1B**, **2B**, and **3B** are for meter cable connections. Connect the cables as instructed below.

1. Connect the solenoid cable (E) between controller connector **1A** and connector **A** on the first fluid panel.
2. Connect the meter cable (F) between controller connector **1B** and connector **B** on the first fluid panel.
3. Repeat the cable connection for each of the fluid panels installed in the system (**2A to A**, **2B to B**, etc.).

NOTE: A knockout, marked , is provided for a customer supplied power input (P) cable with strain relief or for wire conduit.

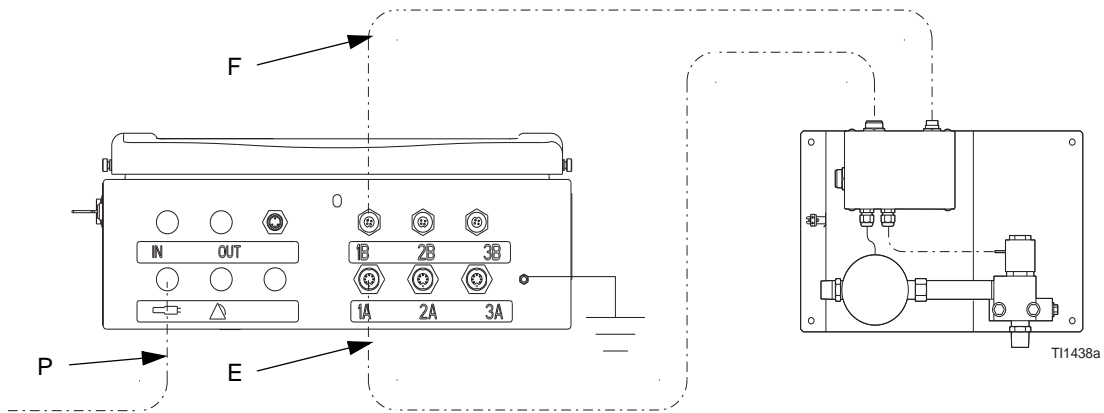

FIG. 10

Ground the System



The system must be properly grounded. Follow the instructions here and on page 6.

ProDispense Controller: Connect a ground wire (G1) to the grounding lug (H1) on the bottom of the controller. Connect the other end of the ground wire to a true earth ground.

Fluid Panels: Connect a ground wire (G) to the grounding lug (H) on the junction box bracket. Connect the other end of the ground wire to a true earth ground.

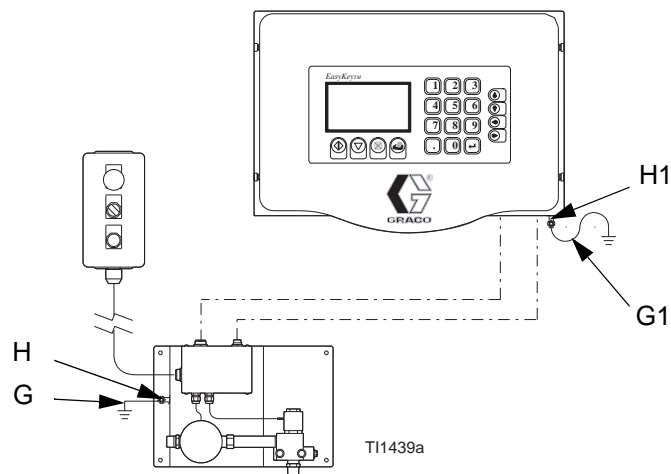

FIG. 11

Feed Pumps or Pressure Pots: See your separate pump or pressure pot manual.

Air and Fluid Hoses: Use only grounded hose.

Fluid Supply Container: Ground the container according to your local code.

Solvent Pails Used when Purging: Ground pails according to your local code. Use conductive, metal pails, placed on a grounded surface. Do not place pails on nonconductive surfaces, such as paper or cardboard.

Check the Resistance



NOTE: To reduce the risk of fire, explosion, or electric shock, the resistance between the ProBatch components and true earth ground must be less than 1 ohm.

Have a qualified electrician check the resistance between each ProDispense component and true earth ground. If the resistance is 1 ohm or greater, a different ground site may be required. Do not operate the system until the problem has been corrected.

Connect a Printer (optional)

Connect the 5 ft. (1.52 m) printer cable (provided with printer kit 239873) between the printer and controller printer connector marked . See FIG. 5, page 15.

NOTE: Accessory Printer Cable 198669, 50 ft. (15.24 m) long, is available. Do not use longer cables.

Connect to a PC or Alarm (optional)

The ProDispense system can be connected to a PC via Modbus RTU network protocol (6) and/or audible alarms (7) as shown in FIG. 12. Refer to field wiring chart, page 60. Follow instructions on page 26 to setup modbus station number and recipe selection. Contact your Graco distributor for Modbus address mapping list.

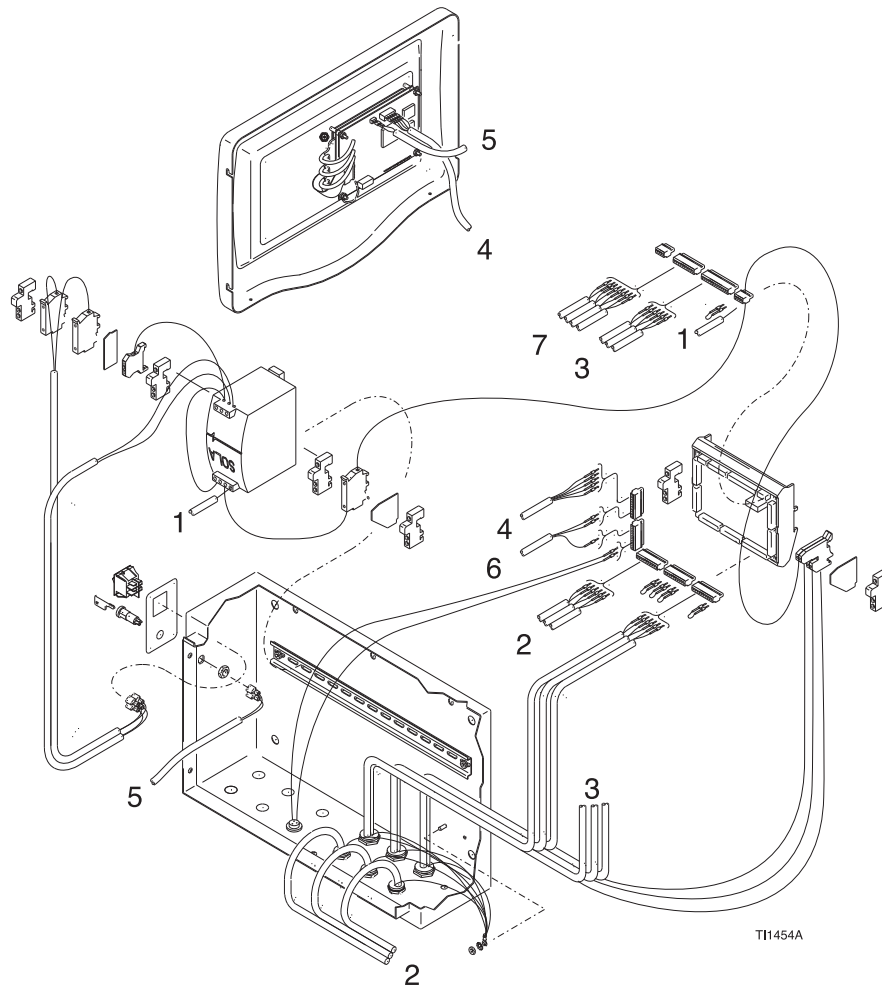

FIG. 12

Before Beginning Operation

- Check all fluid and air connections for correctness and tightness.
- Follow the **Startup** procedure on page 23.

Startup

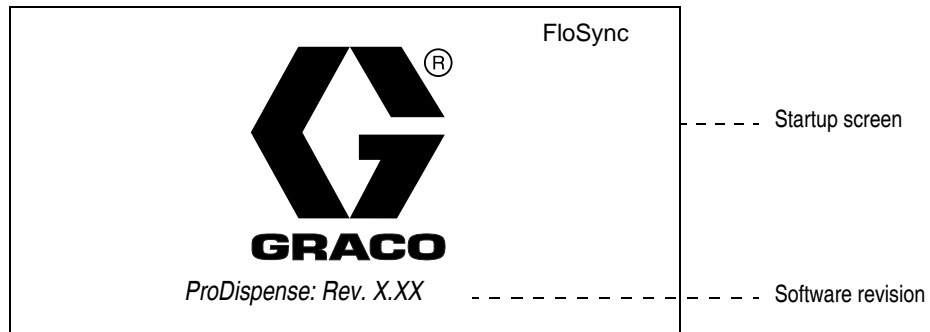

Follow this procedure to start the ProDispense system for the first time (initial startup) or after the system has been shut down.

1. Turn on the power. The ProDispense system startup screen will display while the system is starting, then the Run screen (page 30) or System Setup screen (page 26) will appear, depending on the mode of operation the system is in. For an explanation of operation modes, see page 11.



2. If this is the initial startup, change to Setup Mode (page 25) and complete the setup procedures.
3. Change to the Dispense Mode Run screen if you are not there already (page 29).
4. Make sure the dispense lines run into the proper reservoir.
5. Load the fluids (page 34).

Pressure Relief Procedure

  Follow this procedure to relieve pressure in the fluid panel and dispense line before cleaning, checking, or servicing the equipment or installing or cleaning a dispense valve nozzle.

NOTE: Follow the additional instructions in brackets if a dispense valve is installed on the dispense line.

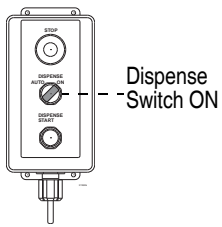

1. Shut off the fluid supply to the ProDispense fluid panel. Follow the Pressure Relief Procedure for the fluid supply system.
2. Place the dispense line [or direct the dispense valve] into a waste container.
3. To begin dispensing, turn the Operator Station dispense switch to ON [and trigger the dispense valve].

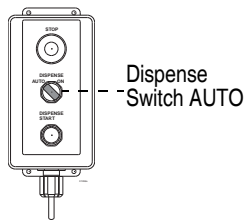

4. When fluid stops flowing and pressure is relieved, [release the dispense valve trigger and] turn the dispense switch to AUTO to stop dispensing.
5. Repeat the process for each fluid panel as needed.

Shutdown

Follow this procedure before servicing the equipment and to avoid having fluid dry in the equipment and fluid lines when the equipment is not being operated.



1. Purge the system until it is clean (page 35).
2. *Relieve the pressure as instructed above.*
3. Turn off the ProDispense controller power switch.

Setup Mode



Setup Mode

Screen Navigation

To enter Setup Mode:

You must have the key supplied with the system. Insert the key into the switch and turn it to Setup Mode . The System Setup screen appears.

 Do not turn the key to Setup Mode while the ProDispense is dispensing or the system will abort the dispense.

SYSTEM SETUP

Day/Month/Year: █ █ █	Dispense Mode: █
Hour:Minute █ █	1=Fluid Station
Language: █	2=Recipe
1=English 2=Spanish	Recipe Selection: █
3=German 4=French	1=User Interface
5=Japanese	2=Network
	Station Number: █

System
Fluids
Recipes
Meters

--- System Setup Screen

--- 4 screen selections

↓
current screen

The name of the screen that is currently displayed is highlighted.
 Press the left or right arrow keys on the keypad to move through the screens.
 Press the up or down arrow keys to move through data fields on the screen.



To exit Setup Mode:





Turn the key to Dispense Mode. The Run screen appears. Refer to page 30.

System Setup Screen

Use system setup to enter the date, time, language to display, dispense mode, means of recipe selection and station number.

SYSTEM SETUP	
Day/Month/Year: [] [] []	Dispense Mode: [] 1=Fluid Station 2=Recipe
Hour:Minute [] []	Recipe Selection: [] 1=User Interface 2=Network
Language: [] 1=English 2=Spanish 3=German 4=French 5=Japanese	Station Number: []
System	Fluids
Recipes	Meters

To setup the system:

1. Type the current date: day (1-31) , month (1-12) , year (2000-2099) .
2. Type the current time: hour (0-23) , minute (0-59) .

NOTE: The ProDispense clock is a 24 hour clock. The date and time are used for date/time stamps on alarms and reports.

3. Type the desired language number (1-5). .

NOTE: Power must be cycled before the language change will take affect.

4. Type the number for the desired dispense mode (1-2). .

Fluid Station: use this mode to select individual fluid stations when dispensing.

Recipe: use this mode to select a recipe when dispensing. Dispensing by recipe will signal all fluid stations included in the recipe to dispense simultaneously.

5. Type the number for the desired recipe selection (1-2). .

User Interface: use to select recipes from the EasyKey pad.

Network: use to select recipes from a networked source.

6. Type the station number (1-99). .

NOTE: This number is used for network communications to identify the station. Each station must have a unique number.

7. Press the right arrow key  to go to the Fluid Setup screen.

Fluid Setup Screen



Use fluid setup to designate the parameters for each fluid you will dispense.

NOTE: Fluid parameters must be set before the fluid can be used in a recipe.

FLUID SETUP			
	Fluid 1	Fluid 2	Fluid 3
Units of Measure 1=cc 2=oz 3=Qt 4=Ltr 5=Gal			
Tolerance %			
Timeout Value (min)			
K-factor (cc/pulse)			
System	Fluids	Recipes	Meters

To set up the fluids:

You can have 1-3 fluid panels connected to the ProDispense controller. Setup the fluids for each of your fluid panels as follows:

1. Type the number for the desired units of measure (1-5). 
2. Type the dispense tolerance percentage (1-99). 
3. Type the timeout value in minutes (1-99). 

If a dispense does not complete by the end of the entered value, a Dispense Timeout alarm occurs. See page 33.
4. Type the fluid meter's K-factor (cc/pulse). 

Fluid Panel part no.	Meter Type	K-factor (cc/pulse)
244599	oil/lubricant	4.73
244600	water/antifreeze	25
244601	grease/coating	0.119
246837	grease/coating	.061
246838	grease/coating	n/a
246839	grease/coating	0.286

NOTE: The K-factors in the table are a starting point. You can calibrate the meter as instructed on page 28.

5. Repeat steps 1-4 for each additional fluid panel.
6. Press the right arrow key  to go to the Recipe Setup screen.

Recipes **Recipe Setup Screen**

Use recipe setup to configure your recipes by assigning a recipe number and designating Target Amounts for each fluid in the recipe.

RECIPE SETUP			
Target Amount	Fluid 1	Fluid 2	Fluid 3
	<input type="text"/>	<input type="text"/>	<input type="text"/>
	<i>ltr</i>	<i>ltr</i>	<i>ltr</i>
Type in 0 for Target Amount if Fluid is not used in this Recipe.			
System	Fluids	Recipes	Meters

To setup the recipes:

1. Type a recipe number (1-250).
 2. Type the Target Amount for each fluid used in the recipe (0-999.99).
- NOTE:** Type in 0 if a fluid is not used in the recipe. The units of measure are set in Fluid Setup (page 27).
3. Press the right arrow key to go to the Calibrate Meter screen.

Meters *** Calibrate Meter Screen**

Use this screen to calibrate your fluid panel meters. All values are in cubic centimeters (cc).

NOTE: Follow the additional instructions in brackets if a dispense valve is installed on the dispense line.

CALIBRATE METER			
	K-factor (cc/pulse)	Dispensed (cc)	Actual (cc)
Fluid 1	04.730	0	<input type="text"/>
Fluid 2	00.119	0	<input type="text"/>
Fluid 3	25.000	0	<input type="text"/>
1) Manually dispense fluid into a calibrated container (minimum of 300 cc).			
2) Type in Actual Value and Press ENTER.			
System	Fluids	Recipes	Meters

To calibrate a meter:

1. Dispense fluid into a calibrated container (minimum 300 cc) by turning the Operator Station dispense switch to ON [and triggering the dispense valve].
 2. Stop dispensing by [releasing the dispense valve trigger and] turning the dispense switch to AUTO.
 3. The amount the controller detected was dispensed appears on the screen in the **Dispensed** column. If the value in the column differs from the measured amount in the container, enter the measured value (in cc) in the **Actual** column.
- NOTE:** If nothing is entered in the Actual column, the K-factor remains unchanged.
4. The controller will calculate the meter K-factor and display the new value in the **K-factor** column.
 5. Repeat the process for each of your fluid panels.

Dispense Mode

Screen Navigation



Dispense Mode

Dispense Mode  is used to dispense a fluid or recipe, check fluid dispense totals, and view the alarms log.

	RECIPE		DISPENSE	ID#
	Fluid 1	Fluid 2	Fluid 3	
	<i>Idle</i>	<i>Idle</i>	<i>Idle</i>	
Target	005.00 ltr	050.00 ltr	010.10 ltr	
Actual	5.00 ltr	51.00 ltr	10.00 ltr	
Tolerance %	5	5	5	
Difference %	0	+2	-1	
	Run	Totals	Alarms	

----- Recipe Dispense screen

----- 3 screen selections

current screen

The name of the screen that is currently displayed is highlighted.

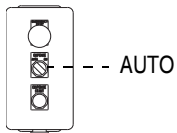

NOTE: The Operator Station dispense switch must be set to AUTO to dispense using the controller.

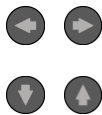

Press the left or right arrow keys on the keypad to move through the screens.

Press the up or down arrow keys to move through data fields on the Run screen.

Run

Run Screen

Use the Run screen to dispense a recipe or individual fluids. The Run screen displays either Recipe Dispense or Fluid Dispense, depending on which Dispense Mode was selected in System setup.

Idle, Dispense, and Alarm Status

In each of the fluid columns, under the Fluid panel number, is a status line, which shows the status of the associated fluid panel. The three possible statuses are:

Idle — fluid panel is idle (not dispensing).

Dispense — fluid panel is dispensing.

Alarm — controller has detected the fluid panel has an alarm condition. To view alarm information, press the right arrow key twice to move to Alarm screen. Refer to page 33.

	RECIPE DISPENSE		ID#
	Fluid 1	Fluid 2	Fluid 3
Status line	Idle	Idle	Idle
Target	005.00 ltr	050.00 ltr	010.10 ltr
Actual	5.00 ltr	51.00 ltr	10.00 ltr
Tolerance %	5	5	5
Difference %	0	+2	-1
Run	Totals	Alarms	

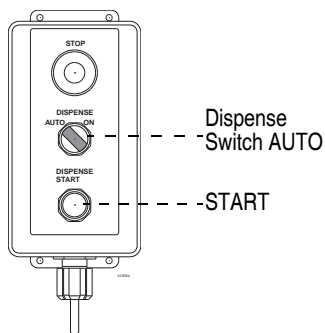
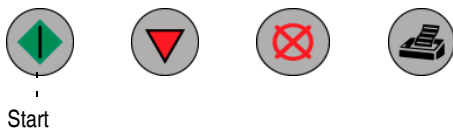

Recipe Dispense

Recipe Dispense displays in the Run screen if “Recipe” is selected as the Dispense Mode. Recipe Dispense is used to dispense a set amount of fluid, typically from more than one fluid panel simultaneously.

1. Place the dispense lines into the receptacle(s) you want to dispense into.
2. Set the Operator Station dispense switch to AUTO.
3. Type the desired recipe number (1-250).

NOTE: The Target value is set in Recipe Setup. You cannot change it in the Run screen.

4. Type a 4 digit ID# if desired.
5. Press the Start button on the Controller or on the Remote Operator Station to begin dispensing the recipe.
6. As the fluids dispense, their statuses on the screen change from **Idle** to **Dispense** and the amounts dispensed appear in the **Actual** row.
7. Each fluid panel stops dispensing when its individual Target is reached.

Status line

FLUID DISPENSE				ID#
	Fluid 1	Fluid 2	Fluid 3	
	<i>Idle</i>	<i>Idle</i>	<i>Idle</i>	
Target	005.00 ltr	050.00 ltr	010.10 ltr	
Actual	5.00 ltr	51.00 ltr	10.00 ltr	
Tolerance %	5	5	5	
Difference %	0	+2	-1	
Run	Totals	Alarms		

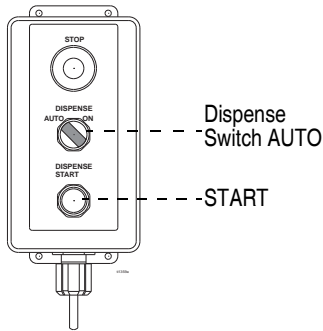



Fluid Dispense

Fluid Dispense displays in the Run screen if “Fluid Station” is selected as the Dispense Mode. Fluid Dispense allows you to select a fluid panel and the amount to dispense on an individual basis.

1. Place the fluid panel dispense line into the receptacle.
2. Type a 4 digit ID# if desired.
3. In the column for the fluid you want to dispense, type the desired amount of fluid in the **Target** field.
4. Press the Start button on the Remote Operator Station to begin dispensing the fluid.
5. As the fluid dispenses, the status on the screen changes from **Idle** to **Dispense** and the amount dispensed appears in the **Actual** row.
6. The fluid panel stops dispensing when its Target is reached.

Totals

Fluid Totals Screen

Press the left  or right  arrow key to select Totals. The Fluid Totals screen shows how much of each of the fluids has been dispensed overall. Two totals are shown. **Grand** totals are tracked from the time the system is first started up and they are not resettable. **Resettable** totals show the total amount of each fluid dispensed since the last reset.



FLUID TOTALS		
Fluid#	Resettable	Grand
1	00005.1 ltr	00312.1 ltr
2	00005.2 ltr	00582.8 ltr
3	00004.8 ltr	00468.2 ltr

Last Reset
Date:23/04/01
Time: 07:35

Press ENTER and CLEAR to reset totals

Run	Totals	Alarms	
-----	--------	--------	--

Press Print  key to print Fluid Totals Report.

Press Clear and Enter keys simultaneously to reset all resettable totals.  + 

 **All resettable totals are reset when Clear and Enter are pressed. Fluid totals cannot be reset individually.**





Clear

Print

Alarms

Alarm History Screen

Press the left  or right  arrow key to select Alarms. This screen summarizes the last five alarms that have occurred.

ALARMS				
Date	Time	Description	Recipe	Fluid
03/09	9:39	Invalid K-factor	10	1
03/08	14:32	Out of Tolerance	0	1
03/05	15:01	Timeout	6	2
03/05	8:12	Out of Tolerance	6	2
03/02	10:59	Invalid K-factor	0	3

Run	Totals	Alarms	
-----	--------	--------	--

Press Print  key to print an Alarms Report.



Print

Out of Tolerance Alarm

This alarm occurs when the current actual dispense is either less than $target - tolerance$ or greater than $target + tolerance$.

Dispense Timeout Alarm

The controller stops an active dispense and initiates this alarm when the current dispense is not finished by the end of the Timeout. Timeout is a value entered during Fluid Setup (page 27).

Invalid K-factor Alarm

This alarm occurs if the meter K-factor is set to zero (00.000).

Memory Failure Alarm

This alarm occurs when the memory has been replaced but not programmed or when the memory has become corrupt.

NOTE: See page 36 for alarm troubleshooting information.

Operation Procedures



Wear eye protection whenever you are dispensing fluid.

NOTE: Follow the additional instructions in brackets if a dispense valve is installed on the dispense line.

Loading Fluid Lines

Follow this procedure to load the fluid lines and purge out any air:

1. Place the dispense line [or direct the dispense valve] into a waste container.
2. To begin loading fluid, turn the Operator Station dispense switch to ON [and trigger the dispense valve].
3. Continue dispensing until all air is purged from the fluid line and fluid flows steadily from the valve.
4. Turn the dispense switch to AUTO to stop dispensing.

Manual Dispense

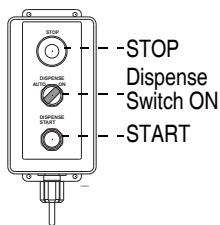

1. Place the dispense line [or direct the dispense valve] into the reservoir.
2. To begin dispensing, turn the Operator Station dispense switch to ON [and trigger the dispense valve].
3. Turn the dispense switch to AUTO [or release the dispense valve trigger] to stop dispensing.

Automatic Dispense

Refer to page 30 for instructions on dispensing a recipe or page 31 to dispense individual fluids.

Purging Fluid

Follow this procedure to purge the fluid lines:



1. Connect the fluid supply line to a solvent supply. Set the fluid supply pressure as low as possible to avoid splashing.
2. To begin purging the lines, direct the fluid outlet into a *grounded metal pail*, turn the Operator Station dispense switch to ON [and trigger the dispense valve].
3. Continue dispensing until fluid lines are clean.
4. Turn the dispense switch to AUTO or [release the dispense valve trigger] to stop dispensing.
5. If you are loading a new material, connect the fluid supply line to the new fluid supply, and follow the procedure for **Loading Fluid Lines**.

Emergency Stop

	RECIPE		DISPENSE	ID#
	Fluid 1	Fluid 2	Fluid 3	
Target	<i>Idle</i>	<i>Idle</i>	<i>Idle</i>	
Actual	005.00 ltr	050.00 ltr	010.10 ltr	
Tolerance %	5	5	5	
Difference %	-98	-99	-97	
Run	Totals	Alarms		

To stop fluid flow at all the fluid panels connected to the controller, press the Stop button on the controller.



Stop

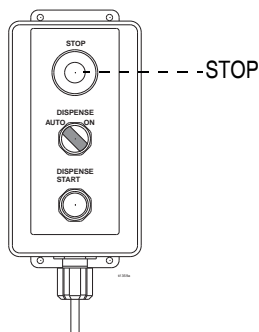

To stop fluid flow at an individual fluid panel, press the STOP button on the Operator Station connected to the fluid panel.

Troubleshooting

Problem	Cause	Solution
Out of Tolerance Alarm	Dispense is under or over tolerance limit set for the fluid.	<p>Run screen shows tolerance difference for last dispense. Use the value to determine whether you should:</p> <ul style="list-style-type: none"> • Increase the tolerance value • <i>Model 244601 only</i> — increase fluid flow by further opening the dispense valve (turn the t-handle clockwise). • Increase or decrease fluid flow rate of the fluid supply.
Dispense Timeout Alarm	The dispense did not complete within set Dispense Timeout value.	<p>Check the following:</p> <ul style="list-style-type: none"> • Fluid supply container is not empty. • Fluid supply equipment is not faulty. • Fluid flow rate is sufficient. • Timeout value is too low and needs increase. • Fluid line is not clogged. • Solenoids are operating. • <i>Model 244601 only</i> — solenoid is receiving air and dispense valve is open. • Cables are properly connected. • Meters are operating and communicating with controller. • Dispense valves are operating. <p>Service equipment as needed.</p>
Invalid K-factor Alarm	Meter K-factor is set to zero (00.000).	Set valid meter K-factor (page 27).
Memory Failure Alarm	The system is not configured.	Enter setup values (page 25).
	The memory is corrupt.	Replace flash EPROM.
No display	No power	Turn on or reconnect power.
	Faulty cable(s)	Replace cable(s).
	Blown fuse(s)	Replace fuse(s).

Service

Removing and Installing Controller



Wear a grounding strap when replacing any of the controller boards to avoid shorting them out.

NOTE: Check with your Graco distributor periodically to see if circuit board or software updates are available.

To remove controller:



1. Turn off controller power switch.

2. Disconnect meter (F), solenoid (E), and power (P) cables and ground wire (G) from the bottom of the controller (B). See FIG. 13.

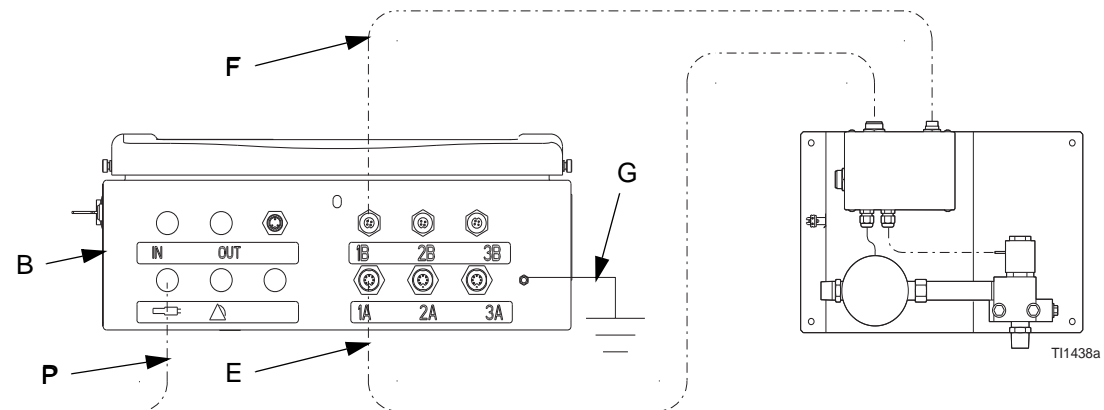

FIG. 13

3. Loosen the four screws (A1) and carefully remove the controller cover (A). See FIG. 14.
4. Disconnect cable connectors (A2, A3) from the display board.
5. Remove the four bolts (B1) and remove the control box. (B).

To install controller:

6. Secure controller (B) to the mounting surface with four bolts (B1).
7. Plug two connectors (A2, A3) into the display board. See FIG. 14.
8. Install controller cover (A) and secure it with four screws (A1).
9. Reconnect ground wire (G) and power (P), meter (F), and solenoid (E) cables to the controller. See FIG. 13.

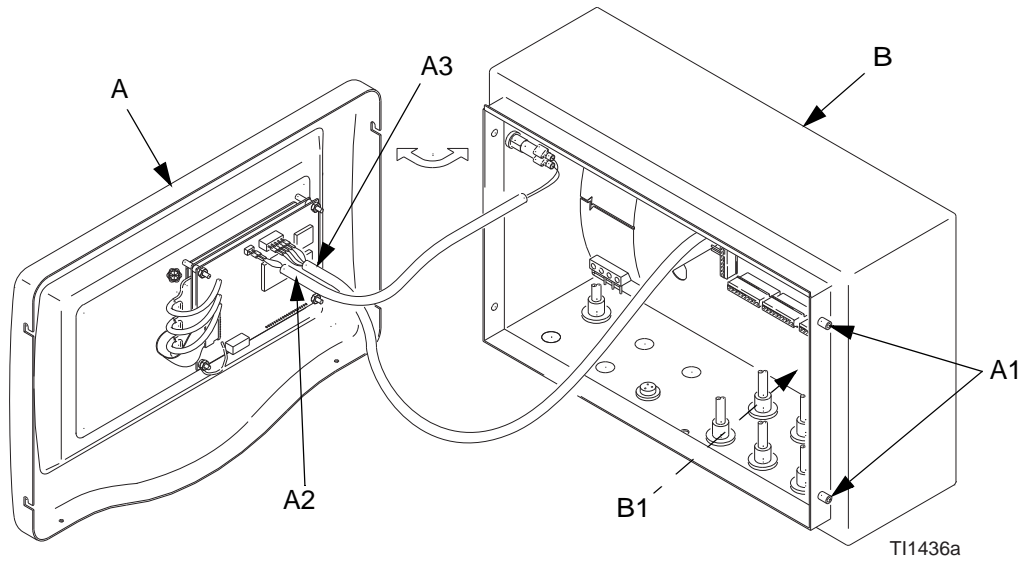

FIG. 14

Replacing Display Board



1. Turn off controller power switch.

2. Remove controller cover (A). See page 37, steps 1-4.
3. Unplug keypad (D) ribbon cable from the display board. Note position of cable in connector. Arrow indicates pin #1, reconnect with pin #1 engaged.
4. Remove four nuts (C1) from the board. See FIG. 15.
5. Disconnect ground wire.
6. Unplug three fiber optic connectors (C3) from the diodes, then remove display board (F).
7. Install parts in reverse order of disassembly.

- If replacing software chip, use a chip puller to remove it.
- Spacers (G) must be used in correct positions to protect the display and board.

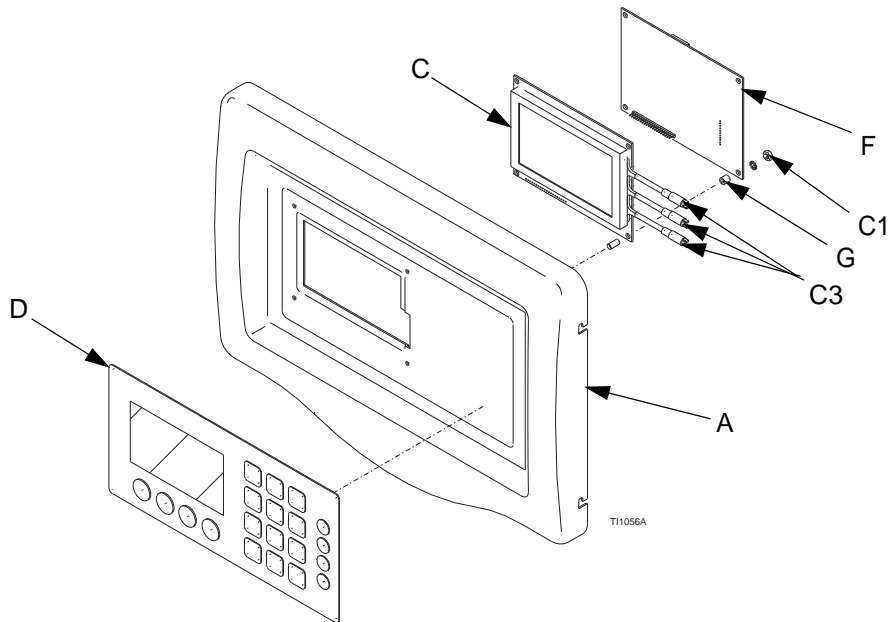

FIG. 15

Replacing Display

1. Follow steps 1 through 6 in the procedure for replacing the display board.
2. Remove the display (C). See FIG. 15.
3. Install the parts in reverse order of disassembly.
 - *Make sure the keypad ribbon cable does not interfere with the display.*
 - *Spacers (G) must be used in correct positions to protect the display and board.*

Replacing Membrane

1. Follow steps 1-6 in the procedure for replacing the display board, page 39.
2. Remove display (C). See FIG. 15.
3. Peel the membrane (D) off the controller cover.
4. Remove adhesive liner from the new membrane. Align the membrane with recessed area on the panel (A), and press it into place.
5. Install parts in reverse order of disassembly.

Spacers (G) must be used in correct positions to protect the display and board.

Replacing Main Board



1. Turn off controller power switch.
2. Remove controller cover. See page 37, steps 1-4.
3. Unplug all wire connectors (G) from the main board (H). See FIG. 16.
4. Squeeze release clips and pull the main board (H) away from the din rail (J).
5. Install parts in reverse order of disassembly.

NOTE: If replacing software chip, use a chip puller to remove it.

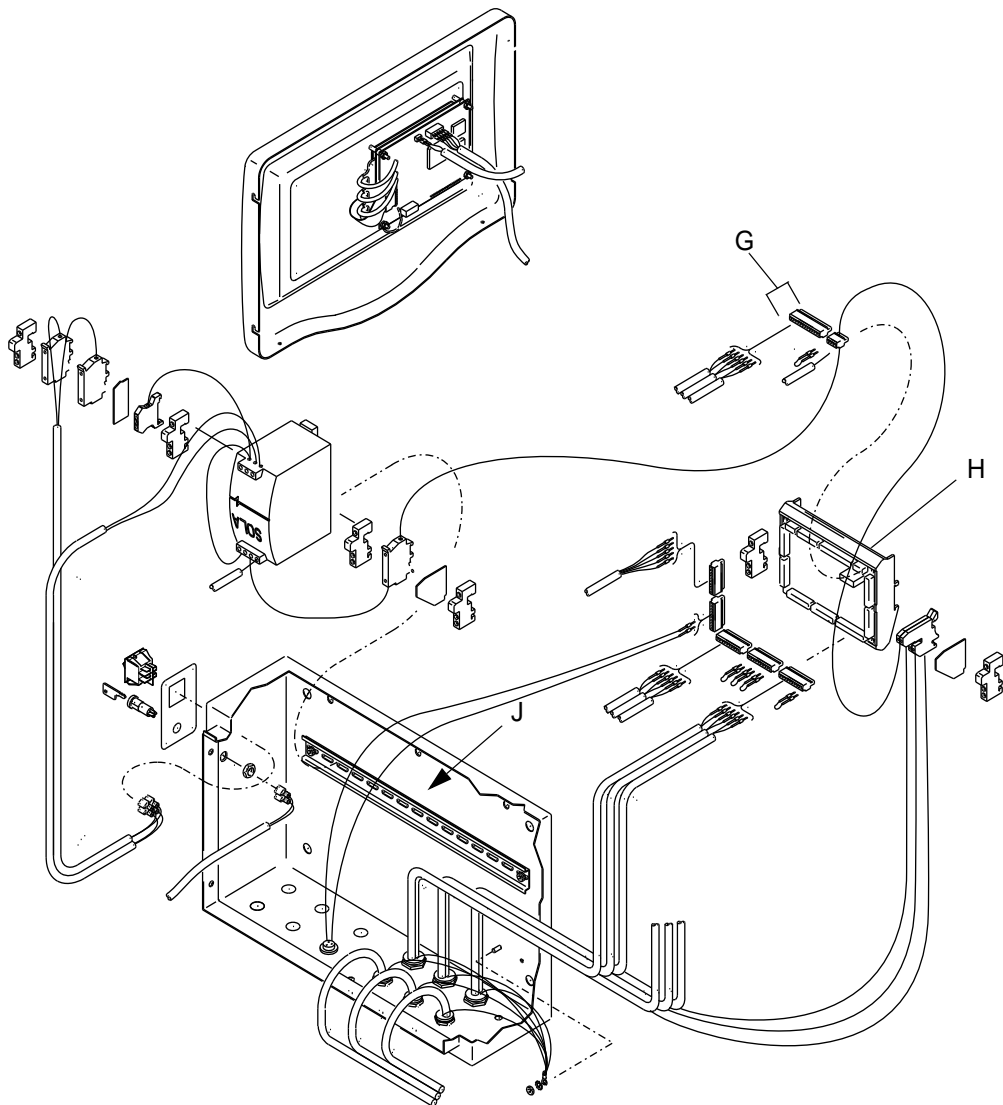

FIG. 16

Replacing Power Supply



1. Turn off controller power switch.

2. Remove controller cover. See page 37, steps 1-4.

3. Unplug all wire connectors from the power supply.

4. Pull the tab up with a screw driver and remove the power supply from the din rail. See FIG. 17.

5. Install parts in reverse order of disassembly.

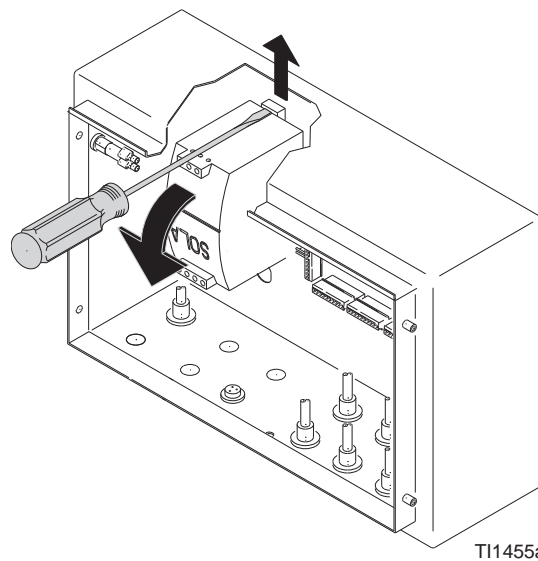

FIG. 17

Replacing Fluid Panel Junction Box



1. Turn off controller power switch.

2. Disconnect three cables (C) from the junction box (J). See FIG. 18.
3. Remove four screws (K) and remove junction box cover (L).
4. Disconnect meter and solenoid wires (M) from the terminal block.
5. Loosen two strain relief connectors (N) to pull out the wires.

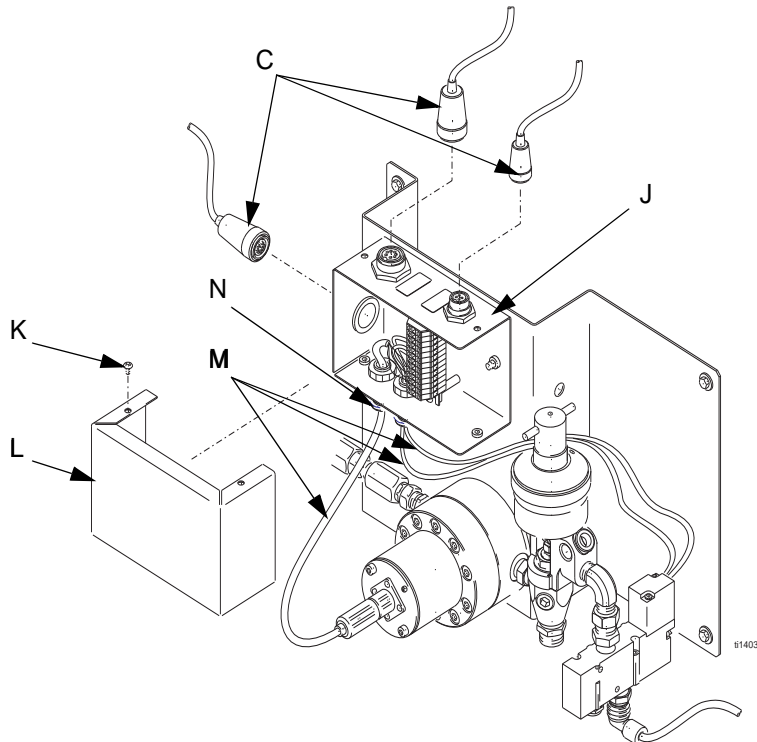

FIG. 18

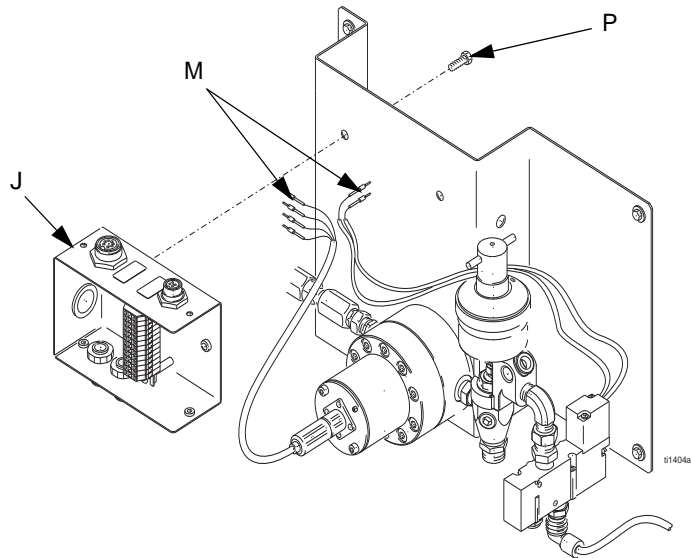
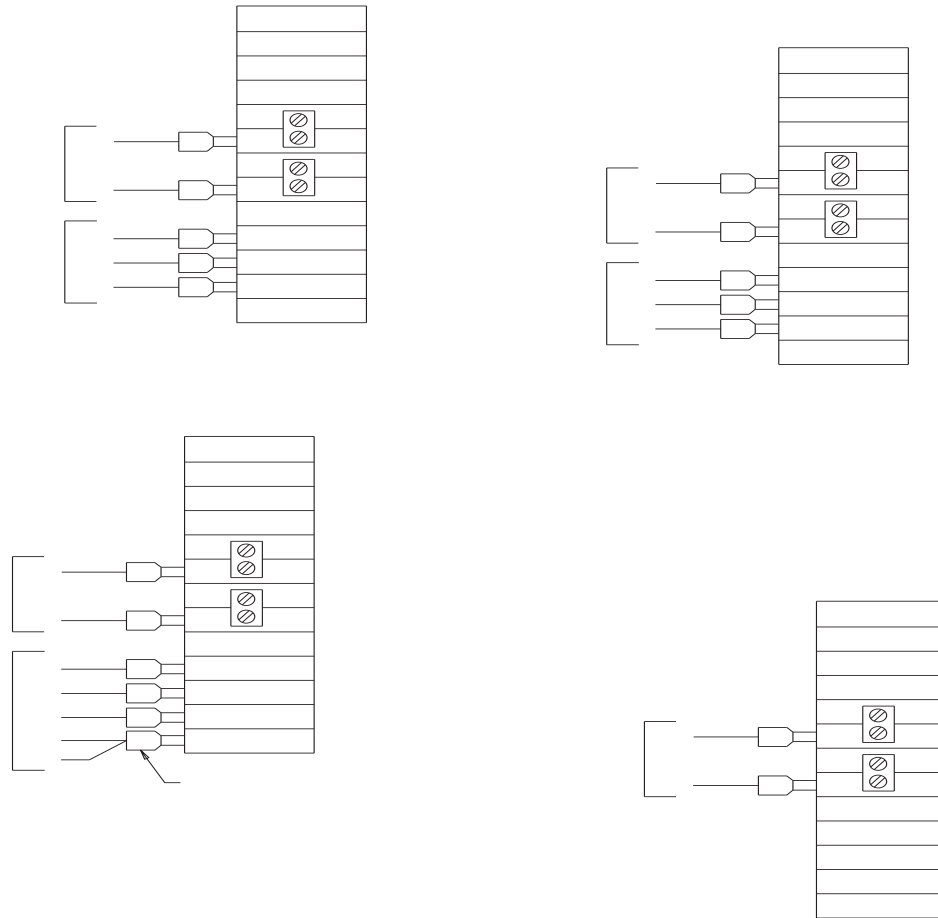

FIG. 19

6. Remove the two screws (P) and remove the junction box (J). See FIG. 19.
7. Secure the new junction box with the two screws (P).

8. Connect meter and solenoid wires (M) to the terminal block. Connect as shown for the specific fluid panel in FIG. 20.

**FIG. 20**

9. Tighten two strain relief connectors (N). See FIG. 18.
10. Secure the cover (L) with four screws (K).
11. Reconnect three cables (C).

Servicing Fluid Panel 244599

Replacing Fluid Meter or Solenoid



1. If necessary, purge ProDispense system (page 35).
2. *Relieve pressure (page 24) and turn off controller power switch.*
3. Follow steps 3–5 on page 43 to disconnect meter and solenoid cables from the terminal block.
4. Disconnect fluid lines from the meter and solenoid.
5. Remove two bolts (6) and washers (7) from the solenoid (3), and remove solenoid and meter assembly. See FIG. 21.
6. Place flats of the solenoid (3) in a vice and unscrew the meter (4).
7. Install new meter or solenoid.
8. Secure the assembly to the fluid panel with solenoid washers (7) and bolts (6).
9. Follow steps 8–10 on page 45 to connect meter and solenoid cables to the terminal block.
10. Connect fluid lines to the meter and solenoid.
11. Load fluid at low pressure and check for leaks. Tighten fittings as needed.

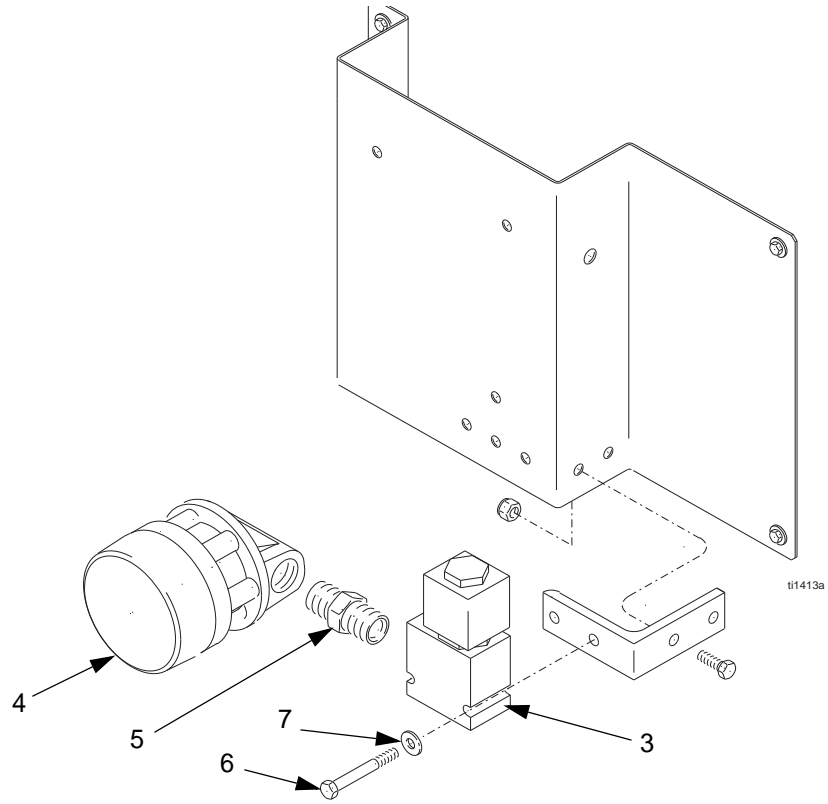

FIG. 21

Servicing Fluid Panel 244600

Replacing Fluid Meter or Solenoid

1. If necessary, purge ProDispense system (page 35).
2. *Relieve pressure (page 24) and turn off controller power switch.*
3. Follow steps 3–5 on page 43 to disconnect meter cable from the terminal block. If replacing the solenoid, also disconnect solenoid cable.
4. **If replacing meter (4):**
 - a. Disconnect fluid line from the meter. Loosen two nuts (A) holding the meter and remove meter. See FIG. 22.
 - b. Secure new meter (4) with the nuts (A). Continue with step 6.
5. **If replacing solenoid (3):**
 - a. Disconnect fluid lines from meter and solenoid.
 - b. Remove two bolts (6) and washers (7) from the solenoid (3), and remove solenoid and meter assembly. See FIG. 22.
 - c. Place flats of the solenoid (3) in a vice and unscrew the meter (4).
 - d. Secure new solenoid (3) to the meter with the nut (A).
 - e. Secure meter and solenoid assembly to the fluid panel with solenoid washers (7) and bolts (6).
6. Follow steps 8–10 on page 45 to connect meter cable (and solenoid cable if it was disconnected) to the terminal block.
7. Connect fluid line(s).
8. Load fluid at low pressure and check for leaks. Tighten fittings as needed.

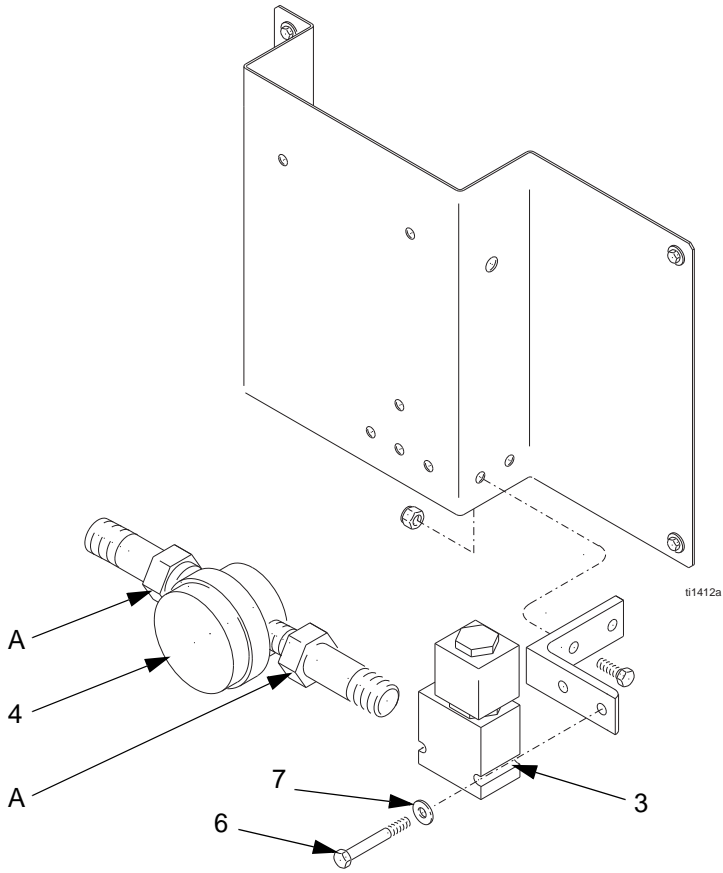

FIG. 22

Servicing Fluid Panel 244601 and 246837

Replacing Fluid Meter, Solenoid, or Dispense Valve



1. If necessary, purge ProDispense system (page 35).
2. *Relieve pressure (page 24) and turn off controller power switch.*
3. Follow steps 3–5 on page 43 to disconnect meter and solenoid cables from the terminal block.
4. Disconnect fluid lines from the meter and dispense valve. Disconnect air line from the solenoid.
5. Remove screw (20) and washer (21) from the meter (4). Remove meter, dispense valve and solenoid assembly from the fluid panel.
Remove fittings from old components and reinstall in new components as needed.
6. **If replacing meter (4):**
 - a. Place flats of the solenoid (3) in a vice and unscrew the meter (4).
 - b. Screw new meter into connector (A).
7. **If replacing dispense valve (19):**
 - a. Place flats of the solenoid (3) in a vice and unscrew the meter (4).
 - b. Unscrew dispense valve (19) from the solenoid (3).
 - c. Screw new dispense valve into connector (C).
 - d. Screw the meter into the connector (A).
8. **If replacing solenoid (3):**
 - a. Place flats of the solenoid (3) in a vice and unscrew dispense valve and meter assembly.
 - b. Screw new solenoid (3) into connector (B).
9. Secure the assembly to the fluid panel with screw (20) and washer (21).
10. Follow steps 8–10 on page 45 to connect meter and solenoid cables to the terminal block.
11. Connect fluid lines to the meter and dispense valve. Connect air line to the solenoid.

12. Load fluid at low pressure and check for leaks. Tighten fittings as needed.

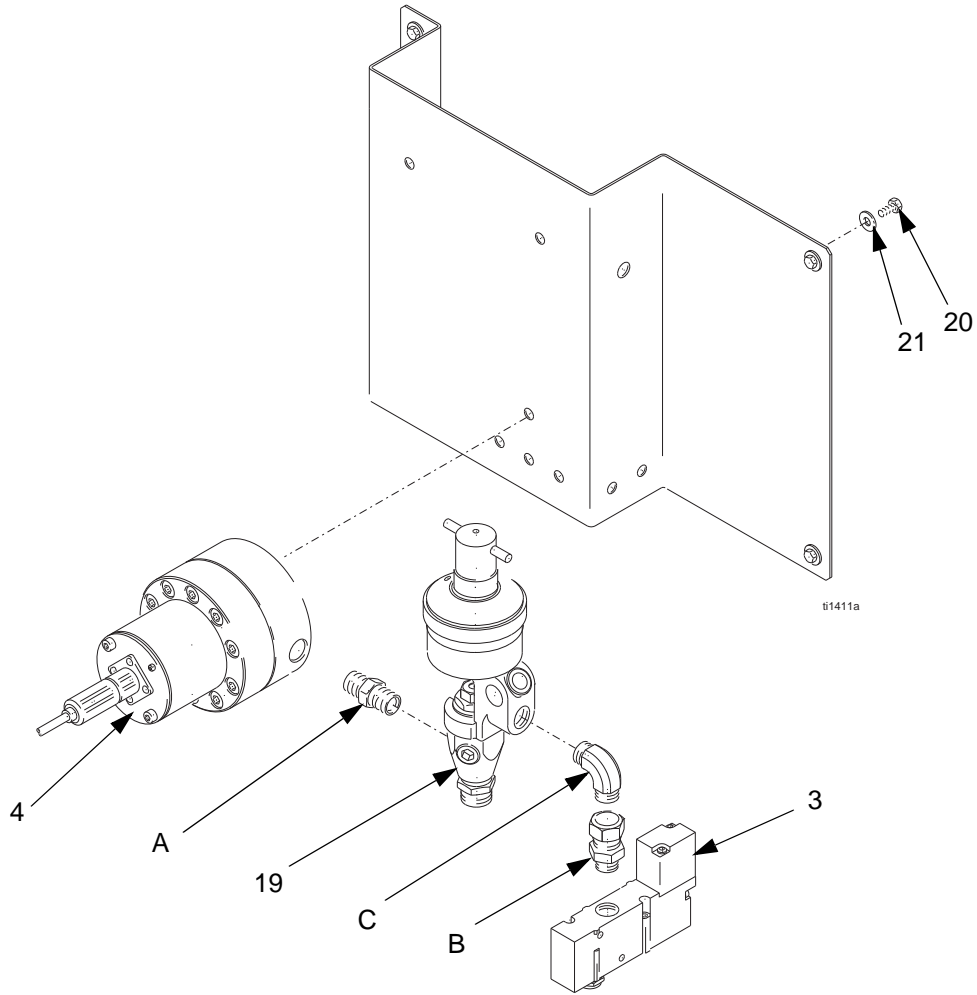

FIG. 23

Servicing Fluid Panel 246838

Replacing Solenoid or Dispense Valve



1. If necessary, purge ProDispense system (page 35).
2. *Relieve pressure (page 24) and turn off controller power switch.*
3. Follow steps 3–5 on page 43 to disconnect meter and solenoid cables from the terminal block.
4. Disconnect fluid lines from the meter and dispense valve. Disconnect air line from the solenoid.
5. Remove dispense valve and solenoid assembly from the fluid panel.
Remove fittings from old components and reinstall in new components as needed.
6. **If replacing dispense valve (19):**
 - a. Place flats of the solenoid (3) in a vice.
 - b. Unscrew dispense valve (19) from the solenoid (3).
 - c. Screw new dispense valve into connector (C).
7. **If replacing solenoid (3):**
 - a. Place flats of the solenoid (3) in a vice and unscrew dispense valve.
 - b. Screw new solenoid (3) into connector (B).
8. Follow steps 8–10 on page 45 to connect meter and solenoid cables to the terminal block.
9. Connect fluid lines to the meter and dispense valve. Connect air line to the solenoid.
10. Load fluid at low pressure and check for leaks. Tighten fittings as needed.

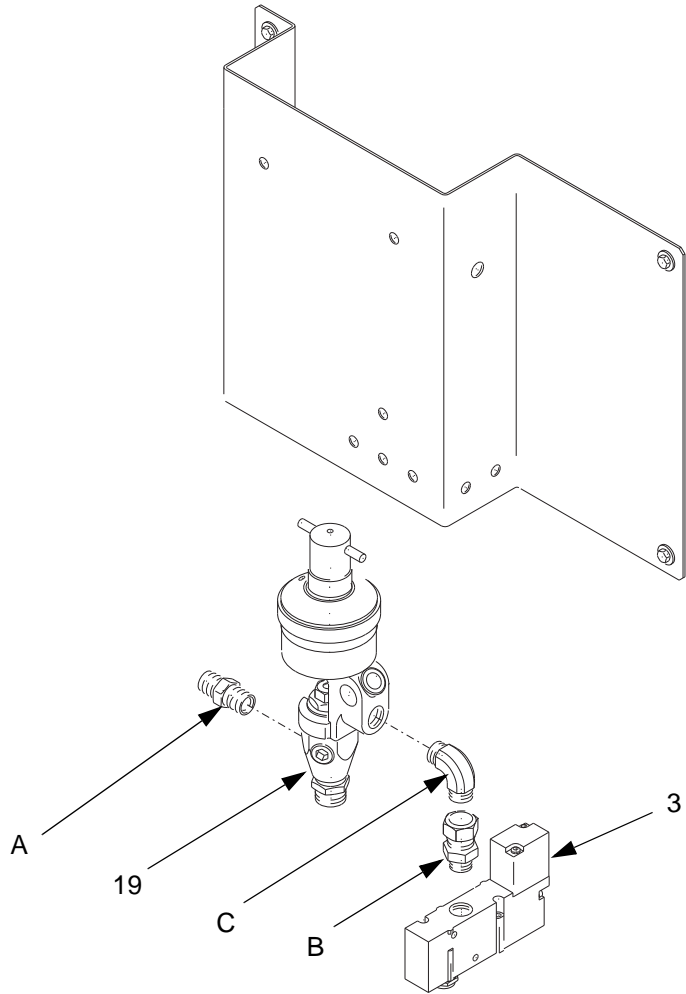

FIG. 24

Servicing Fluid Panel 246839

Replacing Fluid Meter, Solenoid, or Dispense Valve



1. If necessary, purge ProDispense system (page 35).
2. *Relieve pressure (page 24) and turn off controller power switch.*
3. Follow steps 3–5 on page 43 to disconnect meter and solenoid cables from the terminal block.
4. Disconnect fluid lines from the meter and dispense valve. Disconnect air line from the solenoid.
5. Remove screw (20) and washer (21) from the meter (4). Remove meter, dispense valve and solenoid assembly from the fluid panel.
Remove fittings from old components and reinstall in new components as needed.
6. **If replacing meter (4):**
 - a. Place flats of the solenoid (3) in a vice and unscrew the meter (4).
 - b. Screw new meter into connector (A).
7. **If replacing dispense valve (19):**
 - a. Place flats of the solenoid (3) in a vice and unscrew the meter (4).
 - b. Unscrew dispense valve (19) from the solenoid (3).
 - c. Screw new dispense valve into connector (C).
 - d. Screw the meter into the connector (A).
8. **If replacing solenoid (3):**
 - a. Place flats of the solenoid (3) in a vice and unscrew dispense valve and meter assembly.
 - b. Screw new solenoid (3) into connector (B).
9. Secure the assembly to the fluid panel with screw (20) and washer (21).
10. Follow steps 8–10 on page 45 to connect meter and solenoid cables to the terminal block.
11. Connect fluid lines to the meter and dispense valve. Connect air line to the solenoid.

12. Load fluid at low pressure and check for leaks. Tighten fittings as needed.

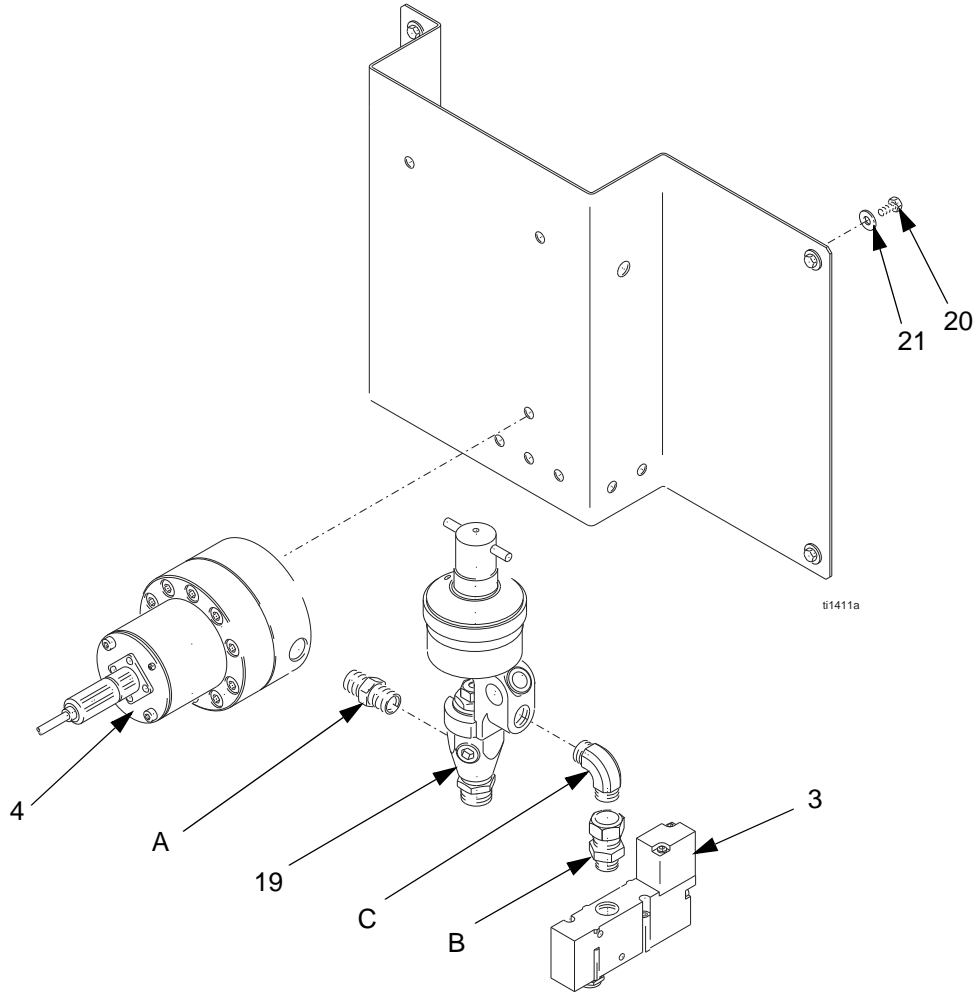

FIG. 25

Wiring Charts

Control Box Wiring Chart				
Wire / Harness	Connection (Connector-Pin)		Color	Function
Internal Wiring	Fuse 1	PWR SW 1A	black	
	Fuse 2	PWR SW 2A	black	
	PWR SW 1	P Supply L	black	
	PWR SW 2	P Supply N	black	
	GND TB	P Supply G	green/yellow	
	P Supply G	P Supply -	green/yellow	
	P Supply -	J7-3	blue	ground
	P Supply +	Fuse 3	blue	
	Fuse 3	J7-4	blue	
	J7-4	J7-1	blue	jumper
	J7-1	terminal block	red	24 VDC power
	J9-9	J9-10	blue	jumper
	J10-1	J10-2	blue	jumper
	J10-2	J10-3	blue	jumper
J10-3	J10-4	blue	jumper	
198556 Main PCB to 7 pin bulkhead (1A)	terminal block	P-1	red	24 VDC power
	J9-5	P-2	red	stop PB
		P-3	open	
	J9-6	P-4	black	start PB
	J6-2	P-5	red	solenoid
	J6-1	P-6	black	ground
	ring terminal	P-7	green	ground
198556 Main PCB to 7 pin Bulkhead (2A)	terminal block	P-1	red	24 VDC power
	J9-3	P-2	red	stop PB
		P-3	open	
	J9-4	P-4	black	start PB
	J6-4	P-5	red	solenoid
	J6-3	P-6	black	ground
	ring terminal	P-7	green	ground

Control Box Wiring Chart				
Wire / Harness	Connection (Connector-Pin)		Color	Function
198556 Main PCB to 7 pin bulkhead (3A)	terminal block	P-1	red	24 VDC power
	J9-1	P-2	red	stop PB
		P-3	open	
	J9-2	P-4	black	start PB
	J6-6	P-5	red	solenoid
	J6-5	P-6	black	ground
	ring terminal	P-7	green	ground
198557 Main PCB to 4 pin bulkhead (1B)	J11-7	P-1	red	24 VDC power
	J11-8	P-2	black	ground
	J11-9	P-3	clear	meter signal
	ring terminal	P-4	drain	ground
198557 Main PCB to 4 pin bulkhead (2B)	J11-4	P-1	red	24 VDC power
	J11-5	P-2	black	ground
	J11-6	P-3	clear	meter signal
	ring terminal	P-4	drain	ground
198557 Main PCB to 4 pin bulkhead (3B)	J11-1	P-1	red	24 VDC power
	J11-2	P-2	black	ground
	J11-3	P-3	clear	meter signal
	ring terminal	P-4	drain	ground
116726 Main PCB to 3 pin bulkhead	J2-6	P-1	black	ground
	J2-7	P-2	clear	printer
		P-3	shield	
197827 Main board to front panel	J3-1	J4-1	brown	RS485_B
	J3-2	J4-2	white	RS485_A
	J3-3	J4-5	black	ground
	J3-5	J4-3	green	DSRI
	J3-10	J4-4	red	VCC
197835 Front panel to key switch	J1-1	SW1	black	key switch
	J1-2	SW2	red	key switch

Fluid Panel Wiring Chart				
Harness	Connection (Connector-Pin)		Color	Function
198426 Control box to fluid panel (1A, 2A, 3A)	Pin-1	Pin-1	orange	
	Pin-2	Pin-2	white	
	Pin-3	Pin-3	green	
	Pin-4	Pin-4	blue	
	Pin-5	Pin-5	black	
	Pin-6	Pin-6	red	
	Pin-7	Pin-7	shield	
198427 Control box to fluid panel (1B, 2B, 3B)	Pin-1	Pin-1	red	
	Pin-2	Pin-2	black	
	Pin-3	Pin-3	white	
	Pin-4	Pin-4	shield	
116669 Remote operator station	F1	2POS SW NC 2	orange	
	F2	2POS SW NO 3	orange	
	F3	Start PB X1	orange	
	F4	Start PB NO 4	brown	
	F5	2POS SW NO 4	brown	
	F6	Stop PB NC 1	brown/green	
	F7	Start PB NO 3	white	
	F8	Start PB X2	black/green	
	F9	Ground Lug	green	
	F10	Stop PB NC 2	red	
	F11	Stop PB NC 1	blue	
	F12	Ground Lug	shield	
	stop PB NC 2	2POS SW NC 1	blue	jumper

Fluid Panel Wiring Chart				
Harness	Connection (Connector-Pin)		Color	Function
244660 Fluid panel junction box Terminal block 5 & 6 are bridged Terminal block 7 & 8 are bridged Used for 244599, 244600, 244601 fluid panels	T Block 1	Pin-1	orange	197573 6 pin bulkhead operator station
	T Block 2	Pin-2	white	
	T Block 3	Pin-5	black	
	T Block 4	Pin-4	blue	
	T Block 7	Pin-6	red	
	ground	Pin-7	green/yellow	
	T Block 1	Pin-1	orange	197574 7 pin bulkhead (A) cable connection
	T Block 2	Pin-2	white	
	T Block 3	Pin-6	red	
	T Block 4	Pin-4	blue	
	T Block 5	Pin-5	black	
	ring terminal	Pin-7	green/yellow	
	T Block 9	Pin-1	red	197575 4 pin bulkhead (B) cable connection
T Block 10	Jumper			
T Block 11	Pin-2	black		
T Block 12	Pin-3	white		
T Block 13	Pin-4	G/Y & shield		
244599 Fluid panel (oil)		TB 10	red	meter wires
		TB 11	black	
		TB 12	white	
		TB 6	black	solenoid wires
		TB 8	black	
244600 Fluid panel (water)		TB 10	brown	meter wires
		TB 11	white	
		TB 12	green	
		TB 6	black	solenoid wires
		TB 8	black	
246837 246839 244601 Fluid panel (grease)		TB 10	red	meter wires
		TB 11	black	
		TB 12	white	
		TB13	green/shield	solenoid wires
		TB 6	black	
	TB 8	black		
246838 Fluid Panel (Grease)		TB 6	black	solenoid wires
		TB 8	black	

Accessories Wiring Chart				
Harness	Connection (Connector-Pin)		Color	Function
	197458 (5 ft., 1.52 m) 198669 (50 ft. 15.24 m) Printer Cable	2		
3		3	clear	
1		5	black	
		4	jumper	
		6		

Field Wiring Chart - Output				
Harness	Connection (Connector-Pin)		Color	Function
		J5-1		
	J5-2			General Alarm (24 VDC)
	J5-3			ground
	J5-4			Fluid 1 Alarm (24 VDC)
	J5-5			ground
	J5-6			Fluid 2 Alarm (24 VDC)
	J5-7			ground
	J5-8			Fluid 3 Alarm (24 VDC)
	J3-8			Modbus B
	J3-9			Modbus A
	J2-6			ground

Parts

Part No. 244561, Controller

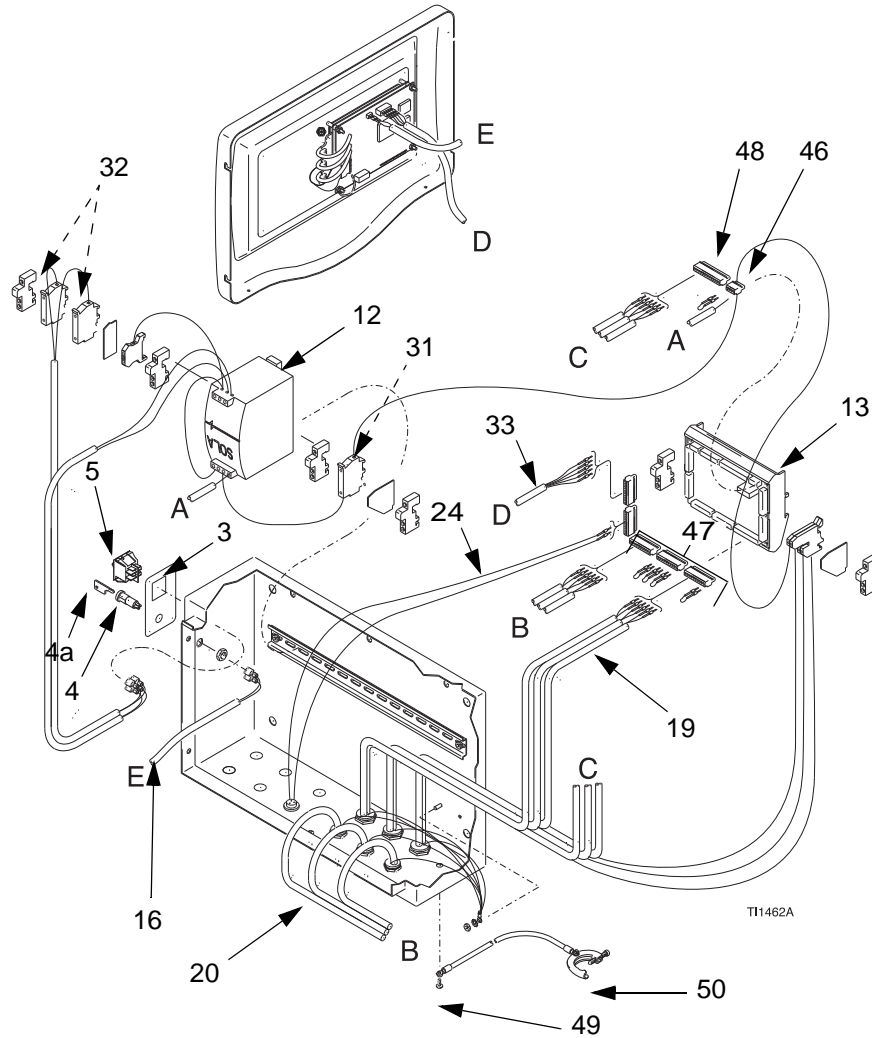

Ref. #	Part #	Description	Qty.
3	197386	LABEL, power switch	1
4	116368	SWITCH, key, 2-position, includes item 4a	1
4a	116370	• KEY PACKAGE (2 duplicate keys)	1
5	116320	SWITCH, power	1
12	196975	POWER SUPPLY, 24 VDC	1
13	244952	BOARD, circuit, main control	1
16	197835	HARNESS, wire	1
18	245222	COVER ASSEMBLY, electrical section, includes items 18a-18h	1
18a	197431	• COVER, enclosure	1
18b	116371	• SPACER, 0.151" ID	4
18c	197281	• SWITCH, membrane	1
18d	198573	• DISPLAY, graphic	1
18e	116374	• SPACER, 0.14" ID	4
18f	244407	• BOARD, circuit, display	1
18g	103181	• WASHER, lock, external, #6	4

Ref. #	Part #	Description	Qty.
18h	100072	• NUT, hex, 6-32 UNC-2B	4
19	198556	WIRE HARNESS, solenoid	3
20	198557	WIRE HARNESS, meter	3
22	194741	LABEL, warning (not shown)	1
24	116726	WIRE HARNESS, printer	1
31	114835	FUSE, time lag, 4 A, 250 V	1
32	120614	FUSE, time lag, 1.6 A, 250 V	2
33	197827	WIRE HARNESS	1
46	116772	CONNECTOR, plug, 3.81 mm, 4 position	1
47	116773	CONNECTOR, plug, 3.81 mm, 10 position	3
48	116774	CONNECTOR, plug, 3.81 mm, 13 position	1
49	116343	SCREW, ground	1
50	222011	CLAMP, grounding	1

Item 18 Cover Assembly
Part No. 245222

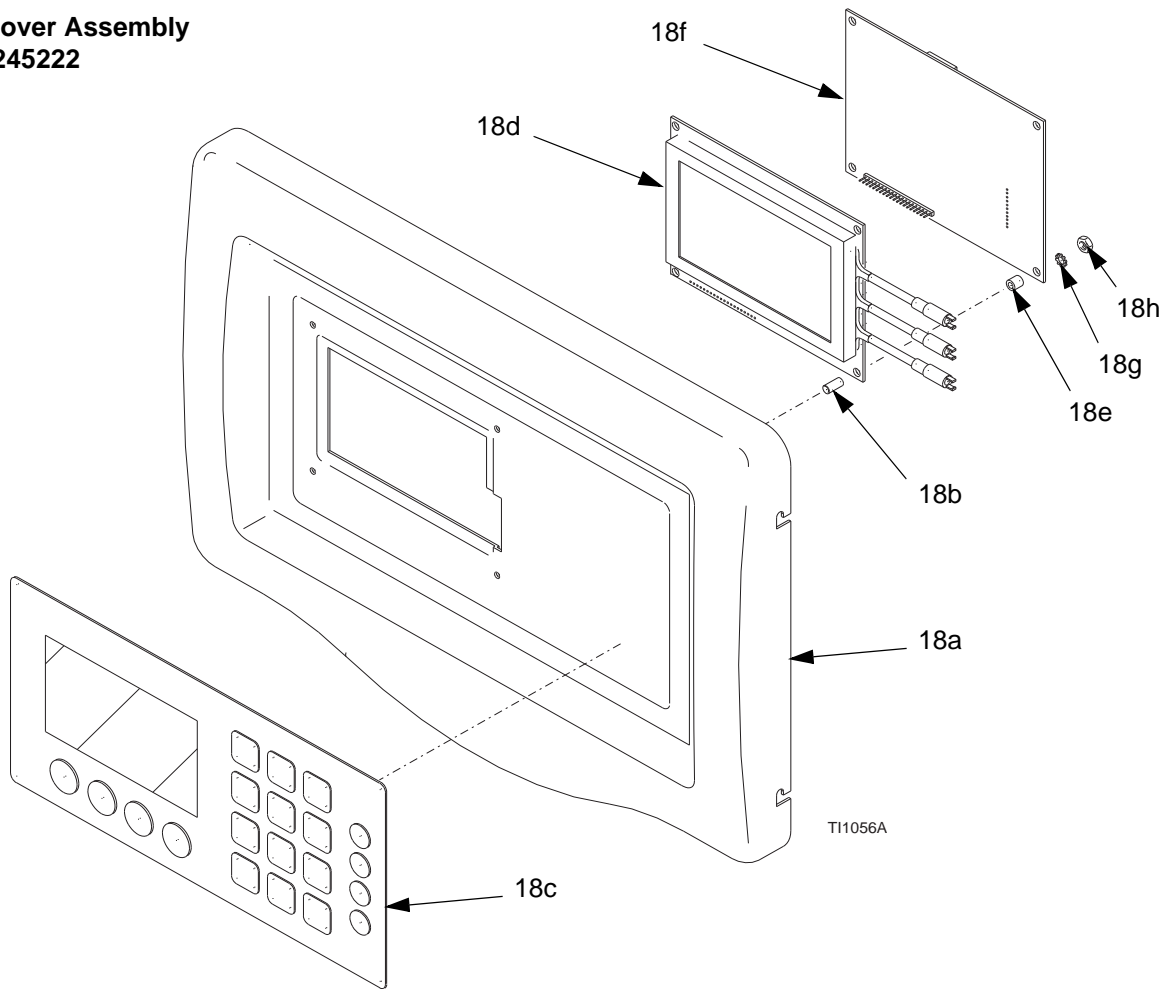

Part No. 244599, Fluid Panel

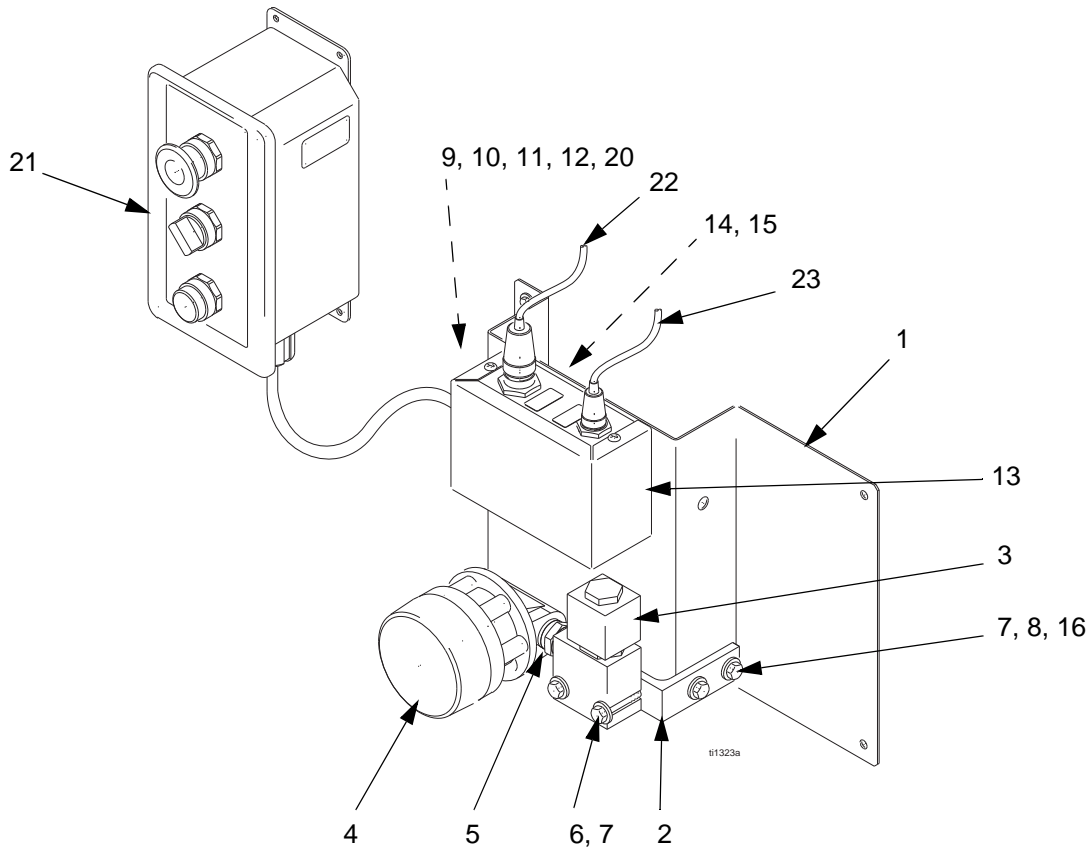

Ref. #	Part #	Description	Qty.
1	116421	PANEL, fluid dispense	1
2	197576	BLOCK, solenoid mount	1
3	110025	VALVE, solenoid	1
4	238618	METER, electronic pulse, see Manual 308245 for parts	1
5	158491	FITTING, nipple, 1/2-14 npt	1
6	102313	SCREW, cap, 1/4-20 UNC-2A x 1.75"	2
7	110755	WASHER, plain, 0.281" ID	6
8	102040	NUT, lock, hex, 1/4-20 UNC-3B	2
9	104029	CLAMP, ground	1
10	104582	WASHER, tab, 5.3 mm ID	1
11	100718	WASHER, lock, #10	1
12	105332	NUT, lock, hex, M5 x 0.8	1
13	244660	JUNCTION BOX, electrical	1
14	101577	SCREW, cap, hex hd., 10-24 UNC-2A x 0.375"	2
15	C38163	WASHER, lock, star, #10	2
16	100021	SCREW, cap, hex hd., 1/4-20 UNC-2A x 1"	2
17	112514	FERRULE, wire, AWG 18 (not shown)	2
18	112512	FERRULE, wire, AWG 26-22 (not shown)	3
20	237569	WIRE ASSY., 25 ft. (7.6 m)	1
21	116669	OPERATOR STATION, remote	1
22	198426	HARNESS, wire	1
23	198427	HARNESS, wire	1

Part No. 244600, Fluid Panel (not ETL listed)

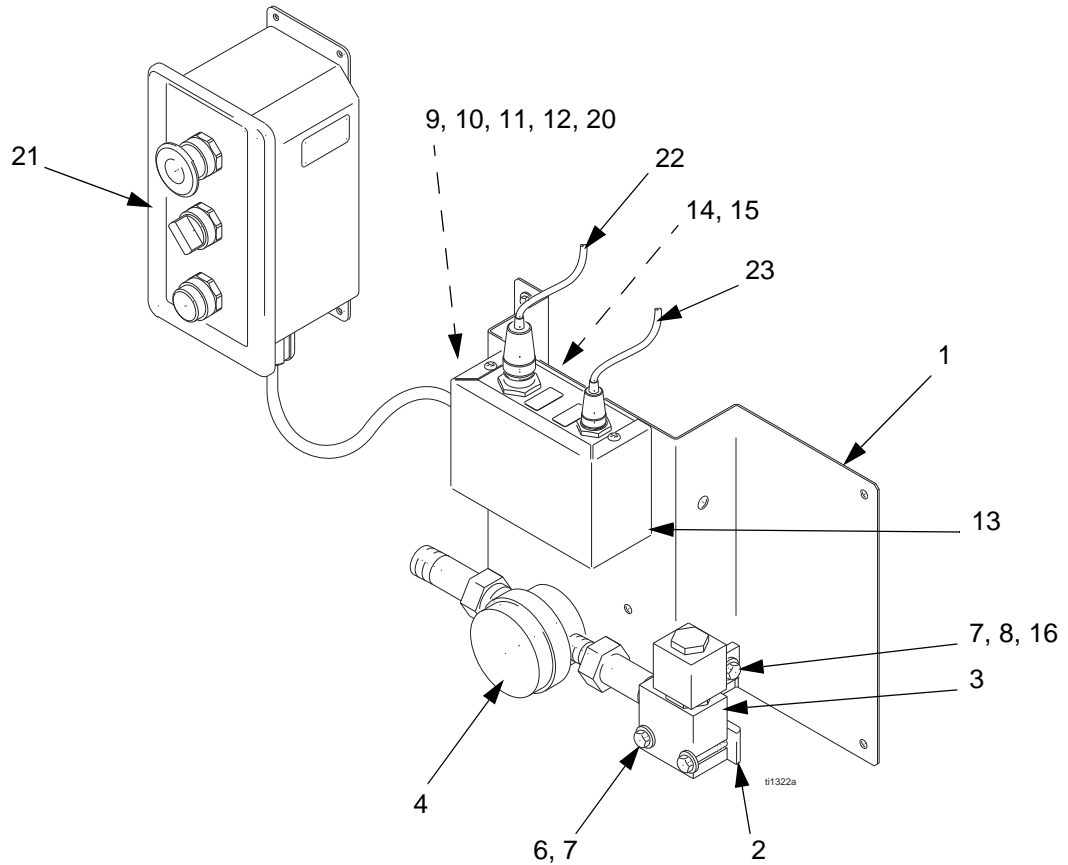

Ref. #	Part #	Description	Qty.
1	116421	PANEL, fluid dispense	1
2	197576	BLOCK, solenoid mount	1
3	110025	VALVE, solenoid	1
4	513891	METER, pulse, water	1
6	102313	SCREW, cap, 1/4-20 UNC-2A x 1.75"	2
7	110755	WASHER, plain, 0.281" ID	6
8	102040	NUT, lock, hex, 1/4-20 UNC-3B	2
9	104029	CLAMP, ground	1
10	104582	WASHER, tab, 5.3 mm ID	1
11	100718	WASHER, lock, #10	1
12	105332	NUT, lock, hex, M5 x 0.8	1
13	244660	JUNCTION BOX, electrical	1
14	101577	SCREW, cap, hex hd., 10-24 UNC-2A x 0.375"	2
15	C38163	WASHER, lock, star, #10	2
16	100021	SCREW, cap, hex hd., 1/4-20 UNC-2A x 1"	2
17	112514	FERRULE, wire, AWG 18 (not shown)	2
18	112512	FERRULE, wire, AWG 26-22 (not shown)	3
20	237569	WIRE ASSY., 25 ft. (7.6 m)	1
21	116669	OPERATOR STATION, remote	1
22	198426	HARNESS, wire	1
23	198427	HARNESS, wire	1

Part No. 244601, Fluid Panel

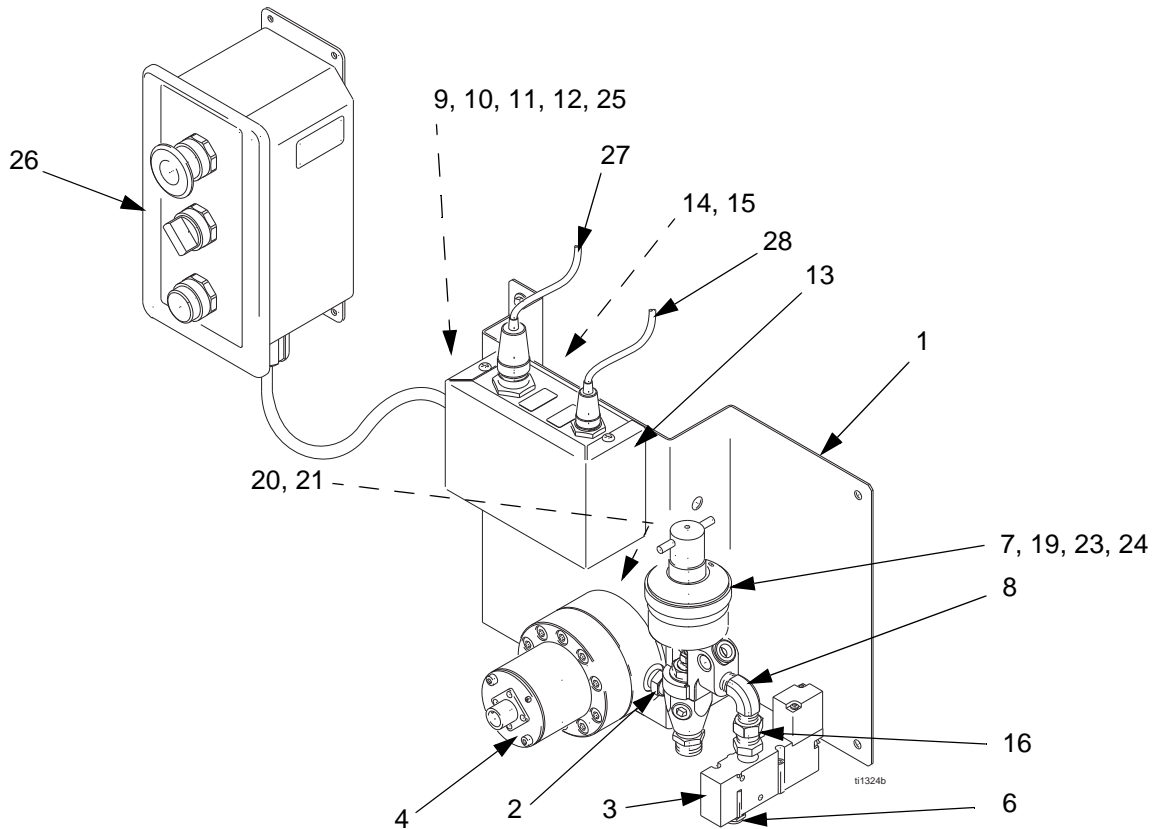

Ref. #	Part #	Description	Qty.
1	116421	PANEL, fluid dispense	1
2	156971	NIPPLE, short, 1/4-18 npt	1
3	116463	VALVE, solenoid	1
4	239716	METER, gear, G3000, see Manual 308778 for parts	1
6	112173	MUFFLER, 1/4-18 npt	1
7	181256	NEEDLE, fluid	1
8	110249	ADAPTER, male, 90° elbow, 1/4-18 npt	1
9	104029	CLAMP, ground	1
10	104582	WASHER, tab, 5.3 mm ID	1
11	100718	WASHER, lock, #10	1
12	105332	NUT, lock, hex, M5 x 0.8	1
13	244660	JUNCTION BOX, electrical	1
14	101577	SCREW, cap, hex hd., 10-24 UNC-2A x 0.375"	2
15	C38163	WASHER, lock, star, #10	2
16	156823	UNION, swivel, 1/4-18 npt	2
17	112514	FERRULE, wire, AWG 18 (not shown)	2
18	112512	FERRULE, wire, AWG 26-22 (not shown)	3
19	205612	VALVE, dispense, automatic, see Manual 306715 for parts	1
20	105468	SCREW, cap, hex hd., M6 x 12	2
21	110755	WASHER, 0.281" ID	2
22	244661	CABLE, G3000 meter (not shown)	1
23	164749	TIP, valve	1
24	164111	WASHER, 0.465" ID	1
25	237569	WIRE ASSY., 25 ft. (7.6 m)	1
26	116669	OPERATOR STATION, remote	1
27	198426	HARNESS, wire	1
28	198427	HARNESS, wire	1

Part No. 246837, Fluid Panel

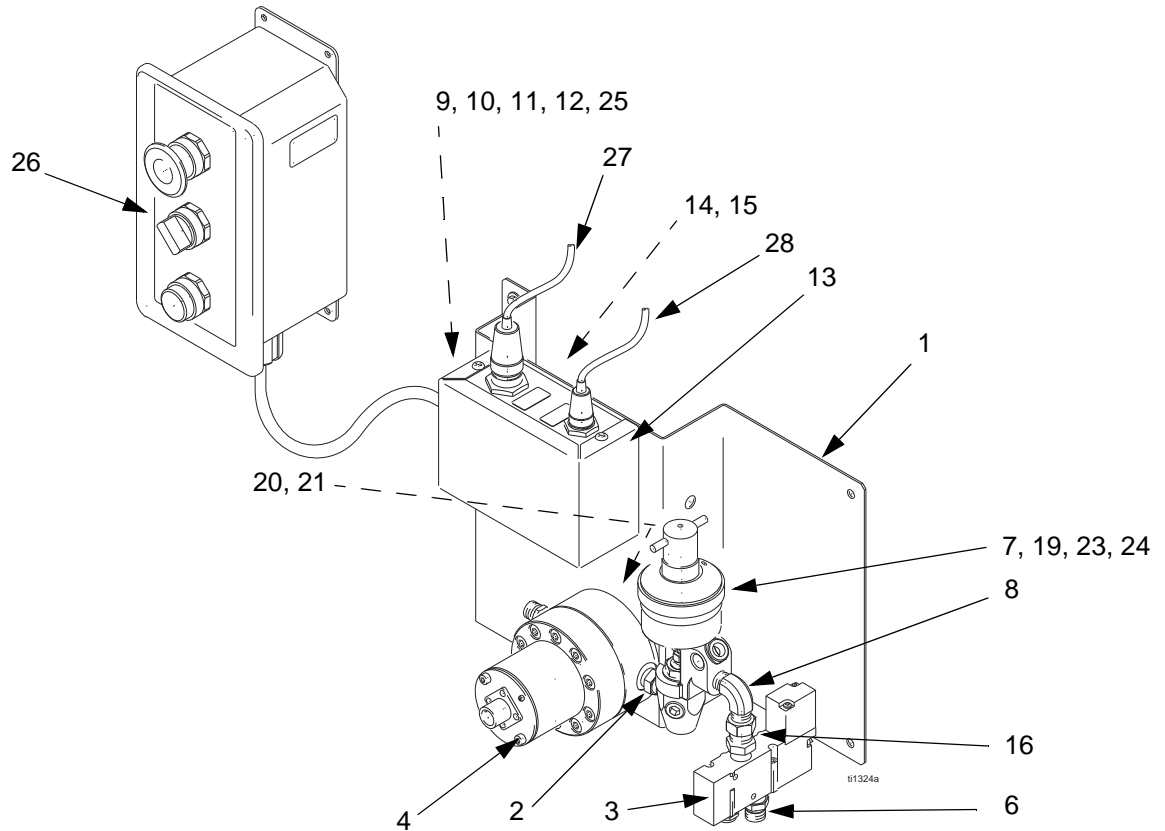

Ref. #	Part #	Description	Qty.
1	116421	PANEL, fluid dispense	1
2	156971	NIPPLE, short, 1/4-18 npt	1
3	116463	VALVE, solenoid	1
4	244292	METER, gear, G3000 HR, see Manual 308778 for parts	1
6	112173	MUFFLER, 1/4-18 npt	1
7	181256	NEEDLE, fluid	1
8	110249	ADAPTER, male, 90° elbow, 1/4-18 npt	1
9	104029	CLAMP, ground	1
10	104582	WASHER, tab, 5.3 mm ID	1
11	100718	WASHER, lock, #10	1
12	105332	NUT, lock, hex, M5 x 0.8	1
13	244660	JUNCTION BOX, electrical	1
14	101577	SCREW, cap, hex hd., 10-24 UNC-2A x 0.375"	2
15	C38163	WASHER, lock, star, #10	2
16	156823	UNION, swivel, 1/4-18 npt	2
17	112514	FERRULE, wire, AWG 18 (not shown)	2
18	112512	FERRULE, wire, AWG 26-22 (not shown)	3
19	205612	VALVE, dispense, automatic, see Manual 306715 for parts	1
20	105468	SCREW, cap, hex hd., M6 x 12	2
21	110755	WASHER, 0.281" ID	2
22	244661	CABLE, G3000 meter (not shown)	1
23	164749	TIP, valve	1
24	164111	WASHER, 0.465" ID	1
25	237569	WIRE ASSY., 25 ft. (7.6 m)	1
26	116669	OPERATOR STATION, remote	1
27	198426	HARNESS, wire	1
28	198427	HARNESS, wire	1

Part No. 246838, Fluid Panel

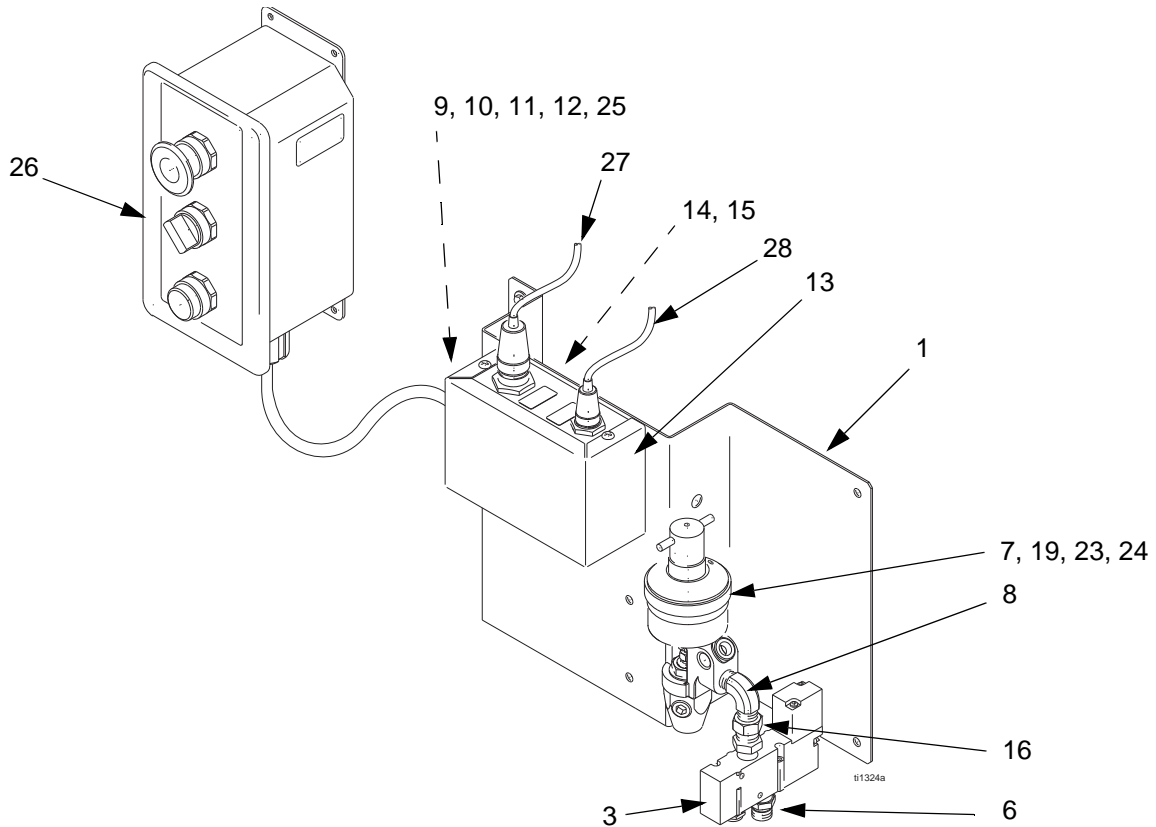

Ref. #	Part #	Description	Qty.
1	116421	PANEL, fluid dispense	1
3	116463	VALVE, solenoid	1
6	112173	MUFFLER, 1/4-18 npt	1
7	181256	NEEDLE, fluid	1
8	110249	ADAPTER, male, 90° elbow, 1/4-18 npt	1
9	104029	CLAMP, ground	1
10	104582	WASHER, tab, 5.3 mm ID	1
11	100718	WASHER, lock, #10	1
12	105332	NUT, lock, hex, M5 x 0.8	1
13	244660	JUNCTION BOX, electrical	1
14	101577	SCREW, cap, hex hd., 10-24 UNC-2A x 0.375"	2
15	C38163	WASHER, lock, star, #10	2
16	156823	UNION, swivel, 1/4-18 npt	2
17	112514	FERRULE, wire, AWG 18 (not shown)	2
18	112512	FERRULE, wire, AWG 26-22 (not shown)	3
19	205612	VALVE, dispense, automatic, see Manual 306715 for parts	1
22	244661	CABLE, G3000 meter (not shown)	1
23	164749	TIP, valve	1
24	164111	WASHER, 0.465" ID	1
25	237569	WIRE ASSY., 25 ft. (7.6 m)	1
26	116669	OPERATOR STATION, remote	1
27	198426	HARNESS, wire	1
28	198427	HARNESS, wire	1

Part No. 246839, Fluid Panel

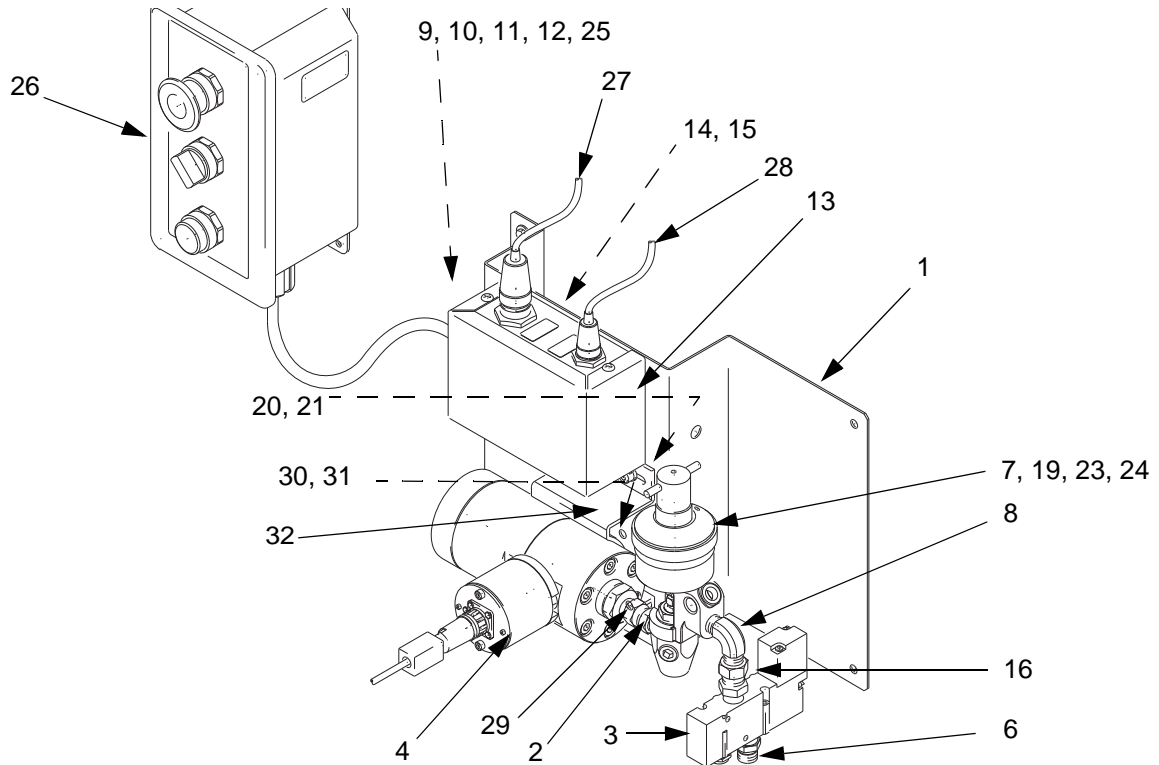

Ref. #	Part #	Description	Qty.
1	116421	PANEL, fluid dispense	1
2	15B556	NIPPLE, short, 1/4-18 npt	1
3	116463	VALVE, solenoid	1
4	246190	METER, heli gear, amb with sensor (see manual 309834 for parts)	1
6	112173	MUFFLER, 1/4-18 npt	1
7	181256	NEEDLE, fluid	1
8	110249	ADAPTER, male, 90° elbow, 1/4-18 npt	1
9	104029	CLAMP, ground	1
10	104582	WASHER, tab, 5.3 mm ID	1
11	100718	WASHER, lock, #10	1
12	105332	NUT, lock, hex, M5 x 0.8	1
13	244660	JUNCTION BOX, electrical	1
14	101577	SCREW, cap, hex hd., 10-24 UNC-2A x 0.375"	2
15	C38163	WASHER, lock, star, #10	2
16	156823	UNION, swivel, 1/4-18 npt	2
17	112514	FERRULE, wire, AWG 18 (not shown)	2
18	112512	FERRULE, wire, AWG 26-22 (not shown)	3
19	205612	VALVE, dispense, automatic, see Manual 306715 for parts	1
20	117028	SCREW, cap, hex hd., M6 x 16	2
21	115226	WASHER, M6	2
22	198578	CABLE, G3000 meter (not shown)	1
23	164749	TIP, valve	1
24	164111	WASHER, 0.465" ID	1
25	237569	WIRE ASSY., 25 ft. (7.6 m)	1
26	116669	OPERATOR STATION, remote	1
27	198426	HARNESS, wire	1
28	198427	HARNESS, wire	1
29	193715	FITTING, union, swivel	1

Technical Data

Power Requirements

Electrical	115/230 VAC, 1.6 amp maximum, 50 or 60 Hz
Pneumatic	85-120 psi (0.59-0.9 MPa, 5.9-9 bar) at 1/4 (Model 244601 only) cfm maximum (filtered to 10 micron)

Number of fluids..... 1-3 valves

Totalizers..... Last dispense
Resettable
Grand

No. of Recipes 250 maximum

Cable Lengths.....

Meter Signal	50 ft. (15.24 m)
Solenoid signal	50 ft. (15.24 m)
Operator Station	10 ft. (3.05 m) 20 ft. (6.10 m) available

Fluid Panels

244599 Oil /Lubricant

Flow rate	0.25-4 gpm (0.95-15 lpm)
Viscosity range	10 wt. oil - #2 grease
Accuracy	± 1/2% on dispenses over one gallon
Resolution	4.73 cc/pulse
Maximum Working Pressure	1500 psi (10 MPa, 103 bar)
Fluid inlet	1/2 npt(f)
Fluid outlet	1/2 npt(f)

244600 Water/Antifreeze (not ETL listed)

Flow rate	0.25-4 gpm (0.95-15 lpm)
Viscosity range	1-20 cps
Accuracy	± 3% on dispenses over one gallon
Resolution	25 cc/pulse
Maximum Working Pressure	250 psi (1.7 MPa, 17 bar)
Fluid inlet	1/2 npt(m)
Fluid outlet	1/2 npt(f)

244601 Grease/Paint

Flow rate	0.2-1 gpm (0.76-3.8 lpm)
Viscosity range	20-5000 cps
Accuracy	± 3% on dispenses over 12 cc
Resolution	0.119 cc/pulse
Maximum Working Pressure	3000 psi (21 MPa, 207 bar)
Maximum Air Pressure	120 psi (0.8 MPa, 8 bar)
Fluid inlet	1/4 npt(f)
Fluid outlet	3/8 npt(m)
Air inlet	1/4 npt(f)

246837 Grease/Paint

Flow rate	.01-.5 gpm (.038-1.9 lpm)
Viscosity range	20-3000 cps
Accuracy	± 1.5% on dispenses over 12 cc
Resolution	.061 cc/pulse
Maximum Working Pressure	3000 psi (21 MPa, 207 bar)
Maximum Air Pressure	120 psi (0.8 MPa, 8 bar)
Fluid inlet	1/4 npt(f)
Fluid outlet	3/8 npt(f)
Air inlet	1/4 npt(f)

246838 Meter-less

(flow meter supplied by user)

Flow rate	(TBD) User supplied
Viscosity range	(TBD) User supplied
Accuracy	(TBD) User supplied
Resolution	(TBD) User supplied
Maximum Working Pressure	3000 psi (21 MPa, 207bar)
Maximum Air Pressure	120 psi (0.8 MPa, 8 bar)
Fluid inlet	(TBD) User supplied
Fluid outlet	1/4 npt(f)
Air inlet	1/4 npt(f)

246839 Grease/Paint/Sealants

Flow rate	.013-6 gpm (.05-22 lpm)
Viscosity range	30-1,000,000 cps
Accuracy	± 5% on dispenses over 12 cc
Resolution	0.286 cc/pulse
Maximum Working Pressure	3000 psi (21 MPa, 207 bar)
Maximum Air Pressure	120 psi (0.8 MPa, 8 bar)
Fluid inlet	3/4 npt(f)
Fluid outlet	3/8 npt(m)
Air inlet	1/4 npt(f)

Wetted Parts

244599	aluminum, carbon steel, bronze, buna-N, stainless steel
244600	brass, stainless steel, polyimide, polypropylene, EPDM o-ring, aluminum, buna-N, carbon steel
244601	303, 400 series, and 416 stainless steel, Tungsten carbide, PTFE, carbon steel, chrome, nylon, UHMWPE, leather

ProDispense™ and EasyKey™ are trademarks of Graco Inc.

Accessories and Kits

Part Number	Description
239873	Printer kit
514037	Printer paper roll
198669	Printer cable 50 ft. (15.24 m)
197902	Paint Shield For display screen, package of 10
198456	Remote Station Extension Cable 20 ft. (6.1 m)
245248	Software Upgrade Kit for Main PCB Includes main PCB chip with software upgrade, chip extractor, and grounding strap.
244840	Software Upgrade Kit for Display PCB Includes display PCB chip, chip extractor, and grounding strap.

Graco Standard Warranty

Graco warrants all equipment manufactured by Graco and bearing its name to be free from defects in material and workmanship on the date of sale to the original purchaser for use. With the exception of any special, extended, or limited warranty published by Graco, Graco will, for a period of twelve months from the date of sale, repair or replace any part of the equipment determined by Graco to be defective. This warranty applies only when the equipment is installed, operated and maintained in accordance with Graco's written recommendations.

This warranty does not cover, and Graco shall not be liable for general wear and tear, or any malfunction, damage or wear caused by faulty installation, misapplication, abrasion, corrosion, inadequate or improper maintenance, negligence, accident, tampering, or substitution of non-Graco component parts. Nor shall Graco be liable for malfunction, damage or wear caused by the incompatibility of Graco equipment with structures, accessories, equipment or materials not supplied by Graco, or the improper design, manufacture, installation, operation or maintenance of structures, accessories, equipment or materials not supplied by Graco.

This warranty is conditioned upon the prepaid return of the equipment claimed to be defective to an authorized Graco distributor for verification of the claimed defect. If the claimed defect is verified, Graco will repair or replace free of charge any defective parts. The equipment will be returned to the original purchaser transportation prepaid. If inspection of the equipment does not disclose any defect in material or workmanship, repairs will be made at a reasonable charge, which charges may include the costs of parts, labor, and transportation.

THIS WARRANTY IS EXCLUSIVE, AND IS IN LIEU OF ANY OTHER WARRANTIES, EXPRESS OR IMPLIED, INCLUDING BUT NOT LIMITED TO WARRANTY OF MERCHANTABILITY OR WARRANTY OF FITNESS FOR A PARTICULAR PURPOSE.

Graco's sole obligation and buyer's sole remedy for any breach of warranty shall be as set forth above. The buyer agrees that no other remedy (including, but not limited to, incidental or consequential damages for lost profits, lost sales, injury to person or property, or any other incidental or consequential loss) shall be available. Any action for breach of warranty must be brought within two (2) years of the date of sale.

Graco makes no warranty, and disclaims all implied warranties of merchantability and fitness for a particular purpose in connection with accessories, equipment, materials or components sold but not manufactured by Graco. These items sold, but not manufactured by Graco (such as electric motors, switches, hose, etc.), are subject to the warranty, if any, of their manufacturer. Graco will provide purchaser with reasonable assistance in making any claim for breach of these warranties.

In no event will Graco be liable for indirect, incidental, special or consequential damages resulting from Graco supplying equipment hereunder, or the furnishing, performance, or use of any products or other goods sold hereto, whether due to a breach of contract, breach of warranty, the negligence of Graco, or otherwise.

FOR GRACO CANADA CUSTOMERS

The parties acknowledge that they have required that the present document, as well as all documents, notices and legal proceedings entered into, given or instituted pursuant hereto or relating directly or indirectly hereto, be drawn up in English. Les parties reconnaissent avoir convenu que la rédaction du présente document sera en Anglais, ainsi que tous documents, avis et procédures judiciaires exécutés, donnés ou intentés à la suite de ou en rapport, directement ou indirectement, avec les procédures concernées.

Graco Information

For the latest information about Graco products, visit www.graco.com.

TO PLACE AN ORDER, contact your Graco distributor, or call to identify the nearest distributor:
1-800-328-0211 Toll Free, 612-623-6921, 612-378-3505 Fax

*All written and visual data contained in this document reflects the latest product information available at the time of publication.
Graco reserves the right to make changes at any time without notice.*

Original instructions. This manual contains English. MM 309301

Graco Headquarters: Minneapolis

International Offices: Belgium, China, Japan, Korea

GRACO INC. AND SUBSIDIARIES • P.O. BOX 1441 • MINNEAPOLIS MN 55440-1441 • USA

Copyright 2001, Graco Inc. All Graco manufacturing locations are registered to ISO 9001.

www.graco.com

Revision K, April 2016