

# PrecisionSwirl™ Orbital Dispenser

309403M  
EN

*For sealant streaming applications. For professional use only.*

**Parts 243402, 243403, 289261, and 289262**

*3500 psi (24.1 MPa, 241 bar) Maximum Fluid Working Pressure*



**Important Safety Instructions**

Read all warnings and instructions in this manual.  
Save these instructions.

**Compact Version**

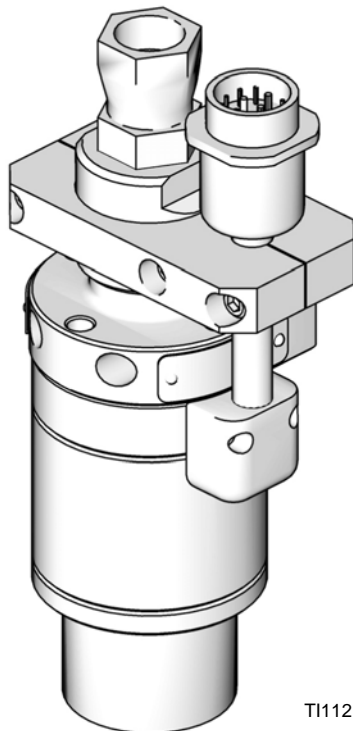

**Standard Version**

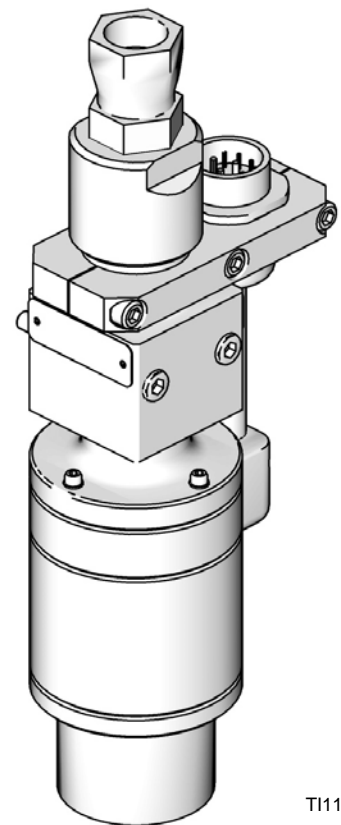

# Contents

<b>Models</b> .....	<b>2</b>	<b>Parts</b> .....	<b>17</b>
<b>Warnings</b> .....	<b>3</b>	<b>Accessories</b> .....	<b>20</b>
<b>Installation</b> .....	<b>6</b>	Motor Control Cable Assemblies .....	20
Tool Mounted Orbital Dispensers .....	6	Torsional Motor Control Cable Assemblies .....	21
Install Orbital Dispenser .....	7	<b>Dimensions</b> .....	<b>23</b>
Cable Assemblies .....	7	Standard Version (243402 and 243403) .....	23
Verify Ground Continuity .....	8	Compact Version (289261 and 289262) .....	24
<b>Operation</b> .....	<b>9</b>	<b>Technical Data</b> .....	<b>25</b>
Pressure Relief Procedure .....	9	<b>Graco Standard Warranty</b> .....	<b>26</b>
Orbital Dispenser Operation .....	10	<b>Graco Information</b> .....	<b>26</b>
<b>Maintenance</b> .....	<b>11</b>		
Preventive Maintenance Schedule .....	11		
<b>Service</b> .....	<b>12</b>		
Servicing the Orbital Dispenser .....	12		
Orbital Dispenser Disassembly .....	12		
Coupler Assembly Replacement .....	13		
Orbital Dispenser Assembly .....	15		

# Models

## Tool Mounted Dispensers

Version	Part, Series	Coupler Offset	Typical Application
Standard	243402, B	0.012 in. for narrow bead widths	hem flange and after hem
Standard	243403, B	0.028 in. for wide bead widths	seam sealing
Compact	289262, A	0.012 in. for narrow bead widths	hem flange and after hem
Compact	289261, A	0.018 in. for medium bead widths	seam sealing

## Cable Assemblies

Part	Description
233125	6 ft (1.8 m) motor extension cable assembly
233124	9 ft (2.7 m) motor extension cable assembly
233123	15 ft (4.6 m) motor extension cable assembly
617870	55 ft (16.8 m) motor extension cable assembly

# Warnings

The following warnings are for the setup, use, grounding, maintenance, and repair of this equipment. The exclamation point symbol alerts you to a general warning and the hazard symbol refers to procedure-specific risk. Refer back to these warnings. Additional, product-specific warnings may be found throughout the body of this manual where applicable.

## WARNING



### EQUIPMENT MISUSE HAZARD

Equipment misuse can cause the equipment to rupture, malfunction, or start unexpectedly and result in serious injury.

- This equipment is for professional use only.
- Read all instruction manuals, warnings, tags, and labels before operating the equipment.
- Use the equipment only for its intended purpose. If you are uncertain about usage, call your Graco distributor.
- Do not alter or modify this equipment. Use only genuine Graco parts and accessories.
- Check the equipment daily. Repair or replace worn or damaged parts immediately.
- Do not exceed the maximum fluid working pressure of 3500 psi (241 bar, 24.1 MPa) to the dispenser or manifold.
- Never exceed the recommended working pressure or the maximum air inlet pressure stated on your pump or in the Technical Data section.
- Be sure that all spray/dispensing equipment and accessories are rated to withstand the maximum working pressure of the pump. Do not exceed the maximum working pressure of any component or accessory used in the system.
- Route hoses and cables away from traffic areas, sharp edges, moving parts, and hot surfaces.
- Do not expose Graco standard hoses to temperatures above 180\_F (82\_C) or below -40\_F (-40\_C).
- Do not use the hoses to pull the equipment.
- Use only fluids and solvents that are compatible with the equipment wetted parts. See the Technical Data sections of all the equipment manuals. Read the fluid manufacturer's warnings.
- Always wear protective eyewear, gloves, clothing, and respirator as recommended by the fluid and solvent manufacturers.
- Comply with all applicable local, state, and national fire, electrical, and other safety regulations.

 **WARNING**
**SKIN INJECTION HAZARD**

Spray from the applicator, hose leaks, or ruptured components can inject fluid into your body and cause extremely serious injury, including the need for amputation. Fluid splashed in the eyes or on the skin can also cause serious injury.

- Fluid injected into the skin might look like just a cut, but it is a serious injury. **Get immediate surgical treatment.**
- Do not point the applicator at anyone or at any part of the body.
- Do not put hand or fingers over the front of the applicator.
- Do not stop or deflect fluid leaks with your hand, body, glove, or rag.
- follow the Pressure Relief Procedure whenever you are instructed to: relieve pressure; stop dispensing; clean, check, or service the equipment; or install or clean a nozzle.
- Tighten all the fluid connections before operating the equipment.
- Check the hoses, tubes, and couplings daily. Replace worn, damaged, or loose parts immediately. Permanently coupled hoses cannot be repaired; replace the entire hose.
- Always wear eye protection and protective clothing when installing, operating, or servicing this dispensing equipment.
- Do not remove or modify any part of the applicator; this can cause a malfunction and result in serious bodily injury.
- Use extreme caution when cleaning or changing nozzles. If the nozzle clogs while applying material, Always follow the Pressure Relief Procedure, then remove the nozzle to clean it.
- Never wipe off build-up around the nozzle or inlet cap until pressure is fully relieved.

**FIRE, EXPLOSION, AND ELECTRIC SHOCK HAZARD**

Improper grounding, poor air ventilation, open flames, or sparks can cause a hazardous condition and result in fire or explosion and serious injury.

- Ground the equipment and the object being dispensed. See Grounding.
- Ground the equipment and the object being sprayed, and all other electrically conductive objects in the dispense area. Proper grounding dissipates static electricity generated in the equipment. See Grounding.
- Do not use this equipment with flammable liquids.
- Keep the dispense area free of debris, including solvent, rags, and gasoline.
- If there is any static sparking or you feel an electric shock while using the equipment, stop dispensing immediately. Do not use the equipment until you have identified and corrected the problem.
- Be sure all electrical work is performed by a qualified electrician only.
- Have any checks, installation, or service to electrical equipment performed by a qualified electrician only.
- Be sure all electrical equipment is installed and operated in compliance with applicable codes.
- Be sure power is disconnected when servicing and repairing equipment.
- Before operating the equipment, extinguish all open flames or pilot lights in the dispense area.
- Do not smoke in the dispensing area.
- Keep liquids away from the electrical components
- Disconnect electrical power at the main switch before servicing the equipment.

 **WARNING****TOXIC FLUID HAZARD**

Hazardous fluids or toxic fumes can cause serious injury or death if splashed in the eyes or on the skin, swallowed, or inhaled.

- Provide fresh air ventilation to avoid the buildup of vapors from the fluid being dispensed.
- Know the specific hazards of the fluid you are using.
- Store hazardous fluid in an approved container. Dispose of hazardous fluid according to all local, state, and national guidelines.
- Always wear protective eyewear, gloves, clothing, and respirator as recommended by the fluid and solvent manufacturer.
- Avoid exposure to heated material fumes.

# Installation

## Tool Mounted Orbital Dispensers

### Compact Version

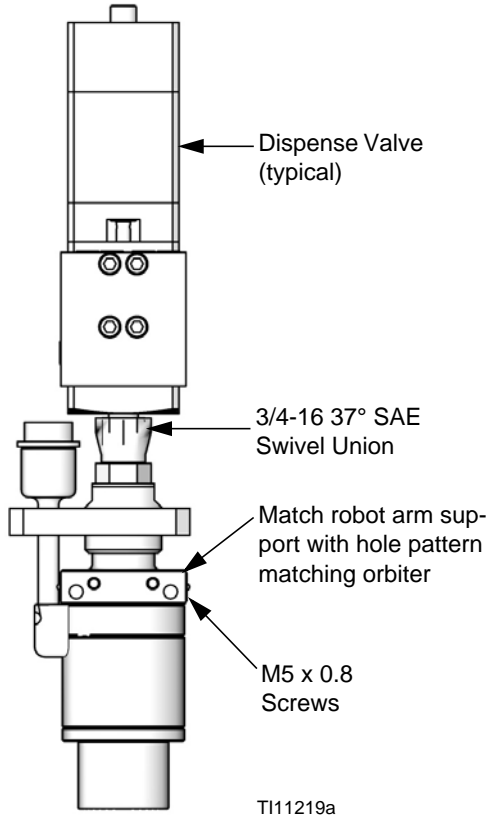

### Standard Version

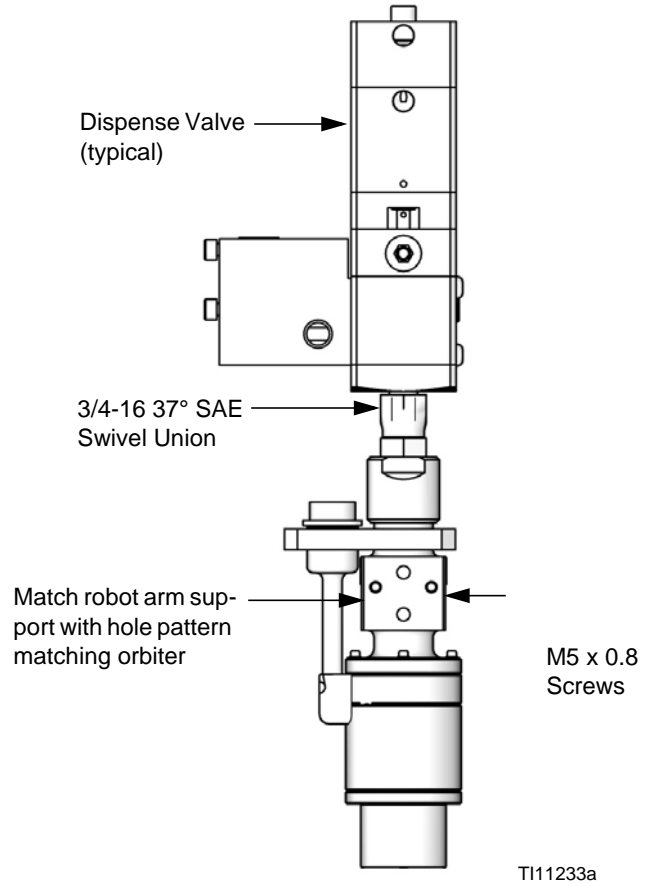

### Mounting Pattern

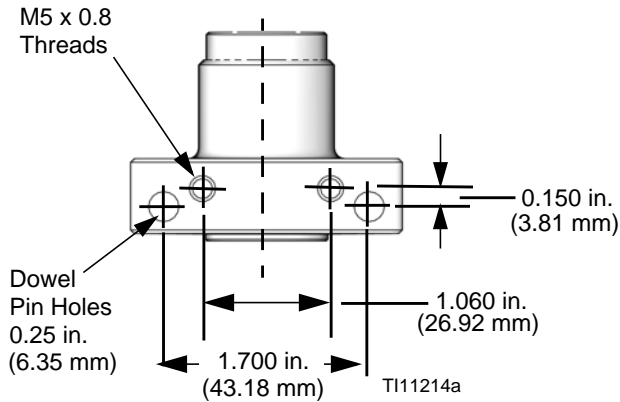

### Mounting Pattern

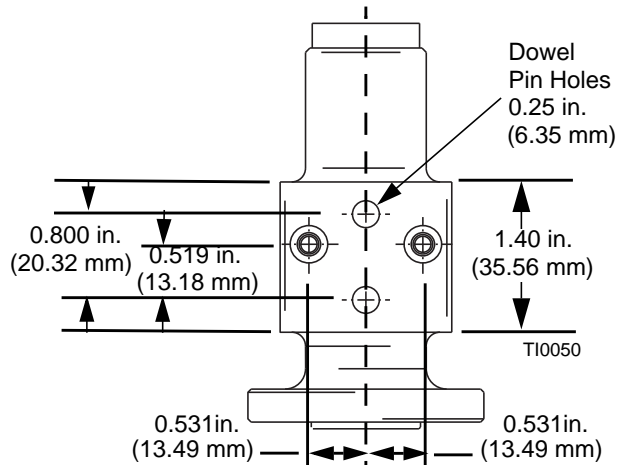

FIG. 1

## Install Orbital Dispenser

To attach the tool mounted orbital dispenser, perform the following steps:

1. Align the dispenser with the alignment pins in the robot arm.
2. Tighten the two M5 x 0.8 screws securing the dispenser to the robot arm.



The dispense valve must also be supported by additional bracketing. The swivel union is not intended to support the weight of the dispense valve.

3. Attach the dispense valve to the orbital dispenser by tightening the 3/4-16 37° SAE swivel union.
4. Make sure the coupling is tight to avoid material leakage.

For detailed specifications, refer to the information provided in **Dimensions** on page 23.

## Cable Assemblies

### CAUTION

Always make connections to the control assembly with power turned off.

### Connect Motor Control Cable

Motor control cables are supplied in four lengths, 6 ft (1.8 m), 9 ft (2.7 m), 15 ft (4.6 m), and 55 ft (16.8). The 55 ft cable may be used by itself. The 6 ft, 9 ft, and 15 ft cable must be used with the 55 ft cable.

To connect the motor cable between the control assembly and the orbital dispenser, do the following:

1. Locate the receptacle for your system:
  - *PrecisionSwirl 918616*: Use the MOTOR CABLE receptacle on the bottom of the control assembly.
  - *PrecisionFlo XL*: Use the SW-1 or SW-2 receptacle on the control box.
  - *PCF, PrecisionSwirl 16K601-16K610, or Expansion Swirl Enclosure 16M350-16M351*: Use the receptacle located on the right side of the enclosure.
2. Connect the orbital dispenser cable (55 ft) to the receptacle located in the previous step.
3. Check the connections to ensure the cable is connected correctly.
4. Route the motor control cable and conform to the following cable routing requirements:
  - Avoid a bend radius of less than 5 in. (12.7 cm).
  - Avoid pinch points.
  - Avoid cable pulling or stretching.
  - Keep cables from rubbing against other components or machinery.
  - If a lot of robot wrist motion is required, leave sufficient cable length to allow for the motion, avoiding any cable droops that may interfere with the machinery or substrate.
  - Route and secure the 7 in. motor cable to minimize any movement. The 7 in. motor cable is not intended to handle severe flexing motions.
  - Cable ties should only be used to loosely bundle hoses together. Do not tighten cable ties to the point where cable movement is restricted.

## Verify Ground Continuity

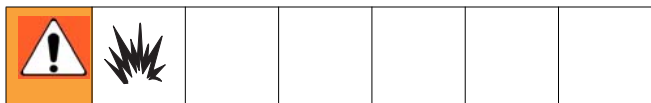

### Verify Ground Continuity

Verify ground continuity between:

- True earth ground and the control assembly ground terminal.
- The orbital dispenser and the robot.

### Adjust Orbital Dispenser

The PrecisionSwirl orbital dispenser is calibrated at the factory. No adjustment is required during initial setup.

### Inspect Orbital Dispenser

Inspect the orbital dispenser cables, material, and air hoses daily for leakage and other visible damage.

## Ground System





The following grounding instructions are minimum requirements for a basic dispensing system. Your system may include other equipment or objects that must be grounded. Check your local electrical code for detailed grounding instructions for your area and type of equipment. Your system must be connected to a true earth ground.

1. *Pump*: connect a ground wire and clamp to a true earth ground as shown in separate pump manual.
2. *Orbital Dispenser*: obtain grounding through the motor cable assembly.
3. *Fluid and air hoses*: use only electrically conductive material and air hoses.
4. *Dispense gun*: obtain grounding through the connection of the hose, or cable.
5. *Air compressor*: follow the manufacturer's recommendations.
6. *Object being sprayed*: according to local code.
7. *Fluid supply container*: according to local code.



# Operation

## Pressure Relief Procedure

						
---	---	---	---	--	--	--

**MATERIAL FLUID HAZARD**  
To reduce risk of injury, wear eye protection, gloves, and protective clothing when installing, operating, or servicing this orbital dispenser.

**SKIN INJECTION HAZARD**  
The system pressure must be manually relieved to prevent the system from starting or spraying accidentally. Fluid under high pressure can be injected through the skin and cause serious injury. To reduce the risk of an injury from injection, splashing fluid, or moving parts, follow the Pressure Relief Procedure whenever you:

- Are instructed to relieve the pressure
- Stop spraying/dispensing
- Install or clean the nozzle
- Check or service any of the system equipment

**PRESSURIZED FLUID HAZARD**  
High pressures can cause serious personal injury. Be sure to open the orbital dispenser during system start-up to alleviate pressure which might occur in the system due to material expansion.

5. Actuate the PrecisionSwirl dispense valve repeatedly until no fluid flows. Have a container ready to catch the drainage from the orbital dispenser.
6. Relieve air pressure to the dispense valve.
7. If the orbital dispenser nozzle or dispense valve fluid hose is completely clogged or if pressure has not been fully relieved after following the steps above, very slowly loosen the 3/4 in.-16 swivel union between the dispense valve and the orbital dispenser, and relieve pressure gradually, then loosen completely. Now clear the nozzle or hose.

This procedure describes how to relieve pressure from the orbital dispenser. See your supply unit or system documentation for instructions on relieving pressure for the entire system. Use this procedure whenever you shut off the orbital dispenser and before checking or adjusting any part of the system, to reduce the risk of serious injury.

1. Shut off the material supply. Follow the Pressure Relief Procedure in the material supply instruction manual.
2. Make sure that all material valves are open.
3. Make sure the pump air supply has been turned OFF.
4. Shut off the conditioning unit to the automatic dispense valve. See the conditioning unit's documentation for more information.

## Orbital Dispenser Operation

The PrecisionSwirl orbital dispenser is calibrated to run from 6600-24,000 RPM maximum, in either automatic or manual control mode.

The orbital dispenser, regardless of the nozzle size, swirls material in a continuous path, over contours, curves, and corners in a consistent bead when the control assembly and dispense valve are configured and adjusted correctly.

The nozzle does not rotate, but its orifice moves in a small circle at high speed to dispense a smooth, neat, consistent bead of concentric loops without dimples, air pockets, depressions, or protuberances. Bead shape is affected by nozzle size, material composition, material pressure, and the distance from the nozzle to the substrate.

The orbital dispenser motor must be turned on at least one second before applying a bead to ensure peak efficiency.

Whether the PrecisionSwirl orbital dispenser is controlled in either the Automatic or Manual mode, material cannot be applied from the orbital dispenser unless the dispense valve is actuated by some other interface to enable material flow.

						
Turn off the PrecisionSwirl orbital dispenser when the unit is not being used. The material inside the orbital dispenser may cure if the motor runs continuously when the orbital dispenser is not being used.						

To extend bearing life, the orbital dispenser motor must not run continuously. Shutting off the motor after each dispense cycle reduces bearing wear and minimizes temperature rise.

# Maintenance

## Preventive Maintenance Schedule

The following schedule is only a general guideline. Therefore, you must establish your own preventive maintenance schedule based on the operating conditions and application of your specific system. These criteria will determine how often maintenance, repair, and rebuild is needed.

Establish a preventive maintenance schedule by recording when and what kind of maintenance is needed. Then determine a regular schedule for checking your system.

Repair technicians must conform to the prescribed maintenance intervals to prevent malfunctions and unscheduled production interruptions.

For components or procedures that are not listed in this table, contact your Graco distributor.

**Table 1. General Guidelines for a Preventive Maintenance Schedule**

<b>Suggested Schedule</b>	<b>Component Description</b>	<b>Refer to:</b>
Daily	Clean the nozzle and deflector.	309403
	Inspect the lower housing on the applicator, especially behind the deflector. Remove the material from behind the deflector to prevent any fluid seepage into the tube bearing.	
Daily	Inspect bellows seal for damage.	309403
Daily	Clean bellows seal.	309403
Weekly	Inspect cables and hoses.	309403
Weekly	Inspect the dispense valve for signs of leakage.	308876 and 309376
Monthly	Change bellows seal***.	309403
3-6 months*	Service the dispense valve.	308876 and 309376
Determined by customer application	Rebuild the PrecisionSwirl applicator.	309403

\*Service life is dependent upon on production load factors and material characteristics.

\*\*\*Preventive maintenance schedule for the bellows seal is dependent on material and application parameters. More frequent changes may be required for difficult materials.

# Service

## Servicing the Orbital Dispenser

This section provides information about the following orbital dispenser components:

- Orbital Dispenser
- Tube Bearing
- Tube Support Bearing
- Orbital Dispenser



 Refer to tool kit 241569 for a 3/32 in. Allen wrench and 1/4 in. combination wrench to facilitate disassembly and reassembly procedures.

## Orbital Dispenser Disassembly



Disassemble the orbital dispenser as follows:

 Tool kit (241569) is required for replacement of the tube support bearing.

Refer to the Parts information on pages 16-17 while performing orbital dispenser disassembly and reassembly procedures.

						
<p><b>ELECTROCUTION HAZARD</b>                      Installing and servicing this equipment requires access to parts which could cause an electric shock or other serious injury. Have only qualified electricians access the control assembly.</p> <p>To reduce the risk of serious injury whenever you are instructed to relieve pressure, always follow the <b>Pressure Relief Procedure</b> on page 9.</p>						

1. Shut off material supply to the orbital dispenser.
2. Relieve material pressure in the system.
3. To ensure that power is removed from the orbital dispenser, perform the following steps:
  - a. At the control assembly, move the MAIN power switch to the OFF position.
  - b. Disconnect the motor control cable from the control assembly.

						
<p><b>HOT MATERIAL AND EQUIPMENT HAZARD</b>                      To prevent personal injury, make sure the orbital dispenser has cooled to ambient temperature before service is performed.</p>						

4. Disconnect the motor control cable from the orbital dispenser.
5. Separate the orbital dispenser from the dispense valve at the 3/4-16 swivel fitting. Carry the orbital dispenser to a work bench to do the following procedures.
6. Remove nozzle (15).
7. Remove the nozzle guard (80) and bellows seal (140).
8. Remove four screws (7) and lockwashers (5). Separate lower housing (150) from motor assembly (6).
9. Remove inlet cap (2) from upper housing (3), exposing top end of tube assembly (13).

 Swivel fitting (1) may remain assembled to inlet cap.

10. Reassemble nozzle (15) loosely onto tube assembly (13). Press nozzle to force tube free of coupler assembly (24).
11. Remove nozzle (15) from tube assembly (13) and remove tube assembly from motor assembly (6) and upper housing (3).
12. If not using coupler repair kit (246292, 246293, 289311, or 289312), remove o-ring (12) from tube assembly (13) and save for later use.
13. Remove four screws (4) and lockwashers (5), and clamp assembly (160). Separate motor assembly (6) from the upper housing (3).

 Do not remove male pin cable connector from motor (6).

# Coupler Assembly Replacement

There are three ball bearing assemblies in the PrecisionSwirl orbital dispenser - two in the motor and one in the motor coupling for tube support.

Only the motor coupling and its bearing may be removed and replaced. The tube support coupler (24) should not be removed unless a new replacement coupler assembly is available. Replace the complete coupler assembly, do not attempt to replace the bearing only.

<p>The repair technician must use the proper tools to avoid damaging the bearings. Tools are provided in bearing repair tool kit 241569.</p>					

## Coupler Assembly Removal

Before removing the coupler assembly (24), you must remove the bearing from the coupler.

1. Place motor assembly onto the coupling support tool. Refer to FIG. 2.
2. Use the push rod tool to press the bearing out of the coupler. The push rod tool is the 4-in. piece of bar stock included in Kit 241569. Discard the bearing.

Do not use the coupler removal tool to remove the bearing.

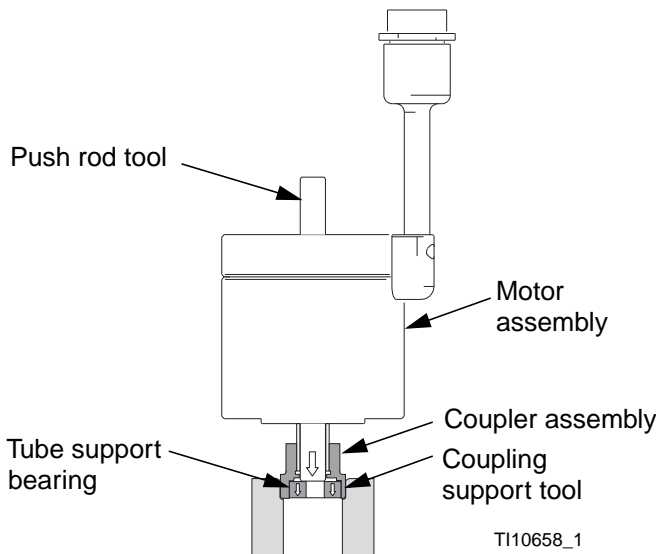

**FIG. 2: Coupler Assembly Removal**

3. Use the gear puller and coupler removal tool included in Kit 241569 to separate the coupler from the motor shaft. Discard the coupler. Refer to FIG. 3.

Align pin in the coupler removal tool with slots in coupler.

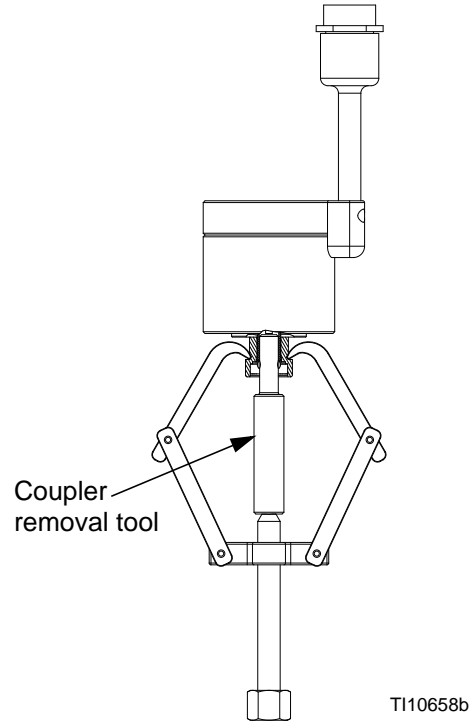

**FIG. 3: Remove Coupler**

## Coupler Assembly

Assemble coupler assembly (24) as follows:

1. Place the motor assembly onto the motor support tool. Refer to FIG. 4.
2. Press a new coupler assembly (24) onto the motor shaft until the assembly bottoms out on the motor shaft. Be extremely careful to ensure the bearing does not bottom out on the coupler. Refer to FIG. 5 for nominal press dimensions.

<b>CAUTION</b>
Do not assemble the 0.028 in. coupler assembly (241466) to the compact orbital dispensers 289261 or 289262. Premature fluid tube failure can result.

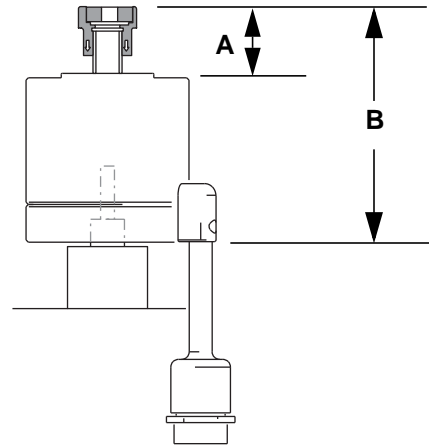

**Dimensions:**  
A = 0.74 in. (18.8 mm)  
B = 2.96 in. (75.2 mm)

**FIG. 5: Nominal Press Dimensions**

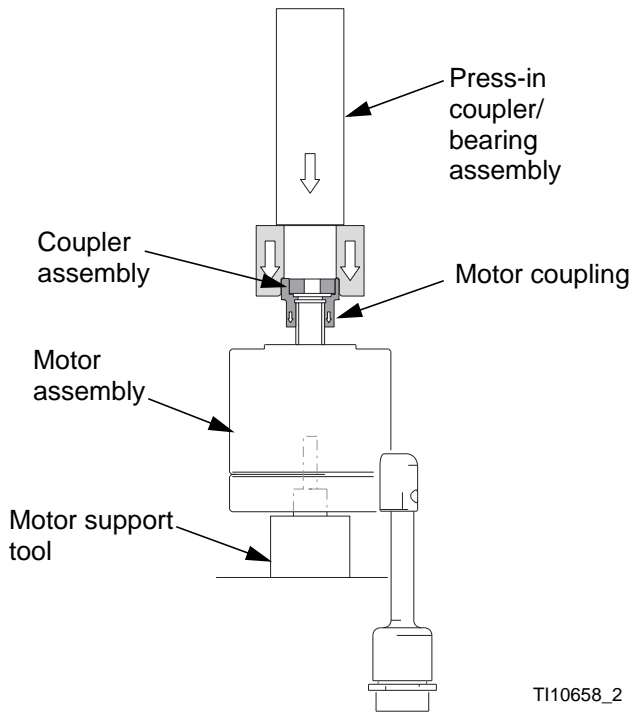

**FIG. 4: Coupler Assembly**

TI10658\_2

## Orbital Dispenser Assembly

Reassemble the orbital dispenser performing the following procedure:

1. Assemble upper housing (3) to motor assembly (6) with four screws (4) and lockwashers (5). Torque the screws to 16-18 in-lb (1.81-2.03 N•m).
2. If you are not using a coupler repair kit, install o-ring (12) onto the tube assembly (13).
3. Apply a small amount of removable Loctite® 641 anaerobic sealant to the inner diameter of the coupler assembly bearing (24). Refer to FIG. 6. Loctite sealant is provided in bearing repair tool kit 241569.

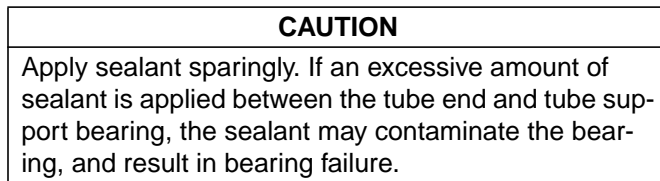

4. Wipe off any excess sealant after tube assembly.

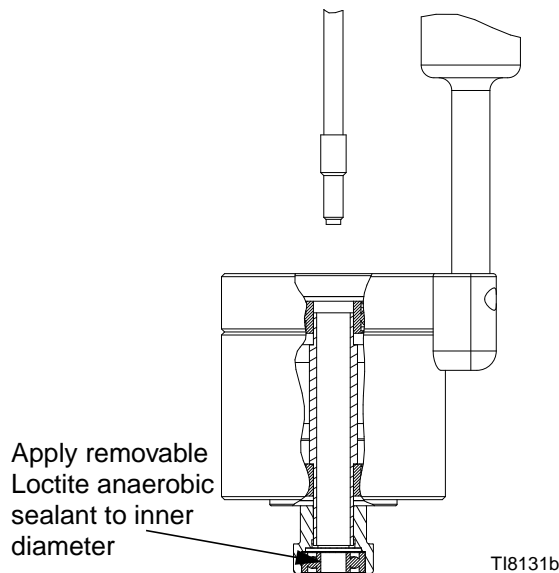

**FIG. 6: Tube Assembly - End Detail**

5. Insert tube assembly (13) into upper housing (3) and through the tube support bearing in motor assembly (6). Push the tube assembly into the counterbore at the top of the upper housing.
6. Prior to installation, lubricate o-ring (12) with PARKER-O-LUBE™ or an equivalent seal lubricant.

7. If the 3/4-16 swivel fitting (1) on the orbital dispenser has been separated from the inlet cap (2), apply Loctite 272 Threadlocker or an equivalent to the 3/4-16 male threads on the fitting and assemble the fitting to the inlet cap.
8. Install the inlet cap/swivel fitting assembly over the tube assembly (13). Screw the fitting onto the upper housing (3) until the tube assembly is firmly clamped against the upper housing.
9. Assemble lower housing (150) to the motor assembly (6) with four screws (7) and lockwashers (5). Torque the screws to 16-18 in-lb (1.81-2.03 N•m).
10. Install the bellows seal (140) and nozzle guard (80).

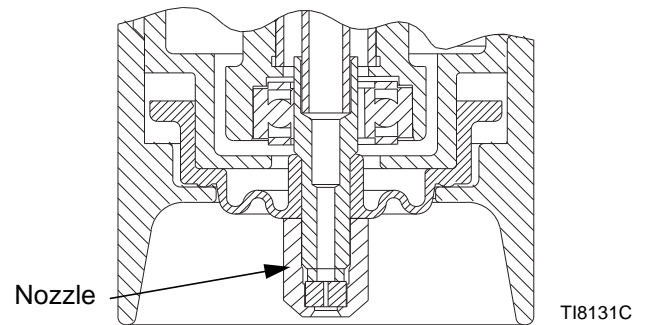

**FIG. 7: Deflector and Nozzle Detail**

11. Assemble nozzle (15) to the tube assembly (13). Torque the nozzle to 12-15 in-lb (1.36-1.69 N•m).

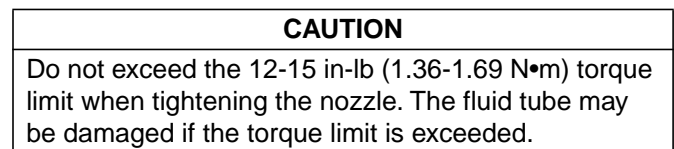

12. Install nozzle guard (80).
13. Allow Loctite anaerobic sealant to cure for 24 hours.
14. Reassemble orbital dispenser to dispense valve. Be sure the 3/4-16 (37° SAE male) fitting on dispense valve is free of fluid material residue.
15. Connect orbital dispenser cable to motor control cable.

16. To reconnect power to the orbital dispenser, perform steps a and b as follows:
  - a. Reconnect the motor control cable to the control assembly.
  - b. At the control assembly, move the MAIN power switch to the ON position.
17. Turn on the material supply to the orbital dispenser.
18. Verify that the orbital dispenser operates correctly.

 The new bearing may require a short break-in period before startup. Run the swirl applicator for 15 minutes at 6600 rpm (no dispensing required). This will ensure the orbiter reaches normal operation status sooner.

19. Return the orbital dispenser to normal operating condition.

## **Bellows Seal Replacement**

1. Clean excess material from the bellows seal (140) and nozzle guard (80).
2. Remove the nozzle guard (80).
3. Remove the nozzle (15).
4. Lift the bellows seal (140) and pull it over the threads on the fluid tube (13).
5. Inspect the surface of the tube bearing. If there are any signs of material contamination, replace the tube bearing and increase the frequency of the seal replacement.



# Parts

## Standard Version (243402 and 243403)

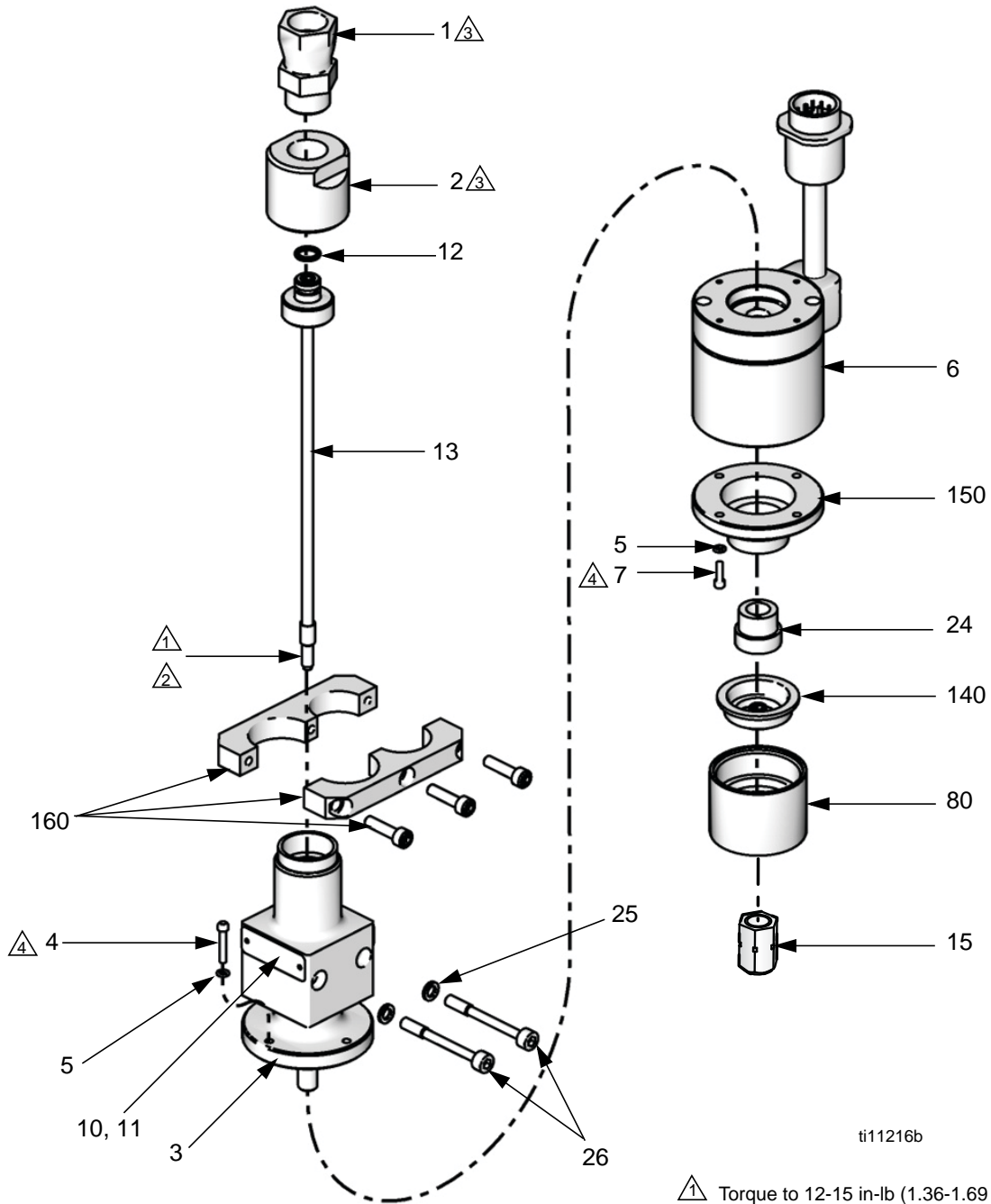

ti11216b

- △ Torque to 12-15 in-lb (1.36-1.69 N•m) maximum.
- △ See Table 4 on page 22.
- △ Torque to 17-20 ft-lb (22.95-27.0 N•m) maximum.
- △ Torque to 10-12 ft-lb (27.0-33.75 N•m) maximum.

**Compact Version (289261 and 289262)**

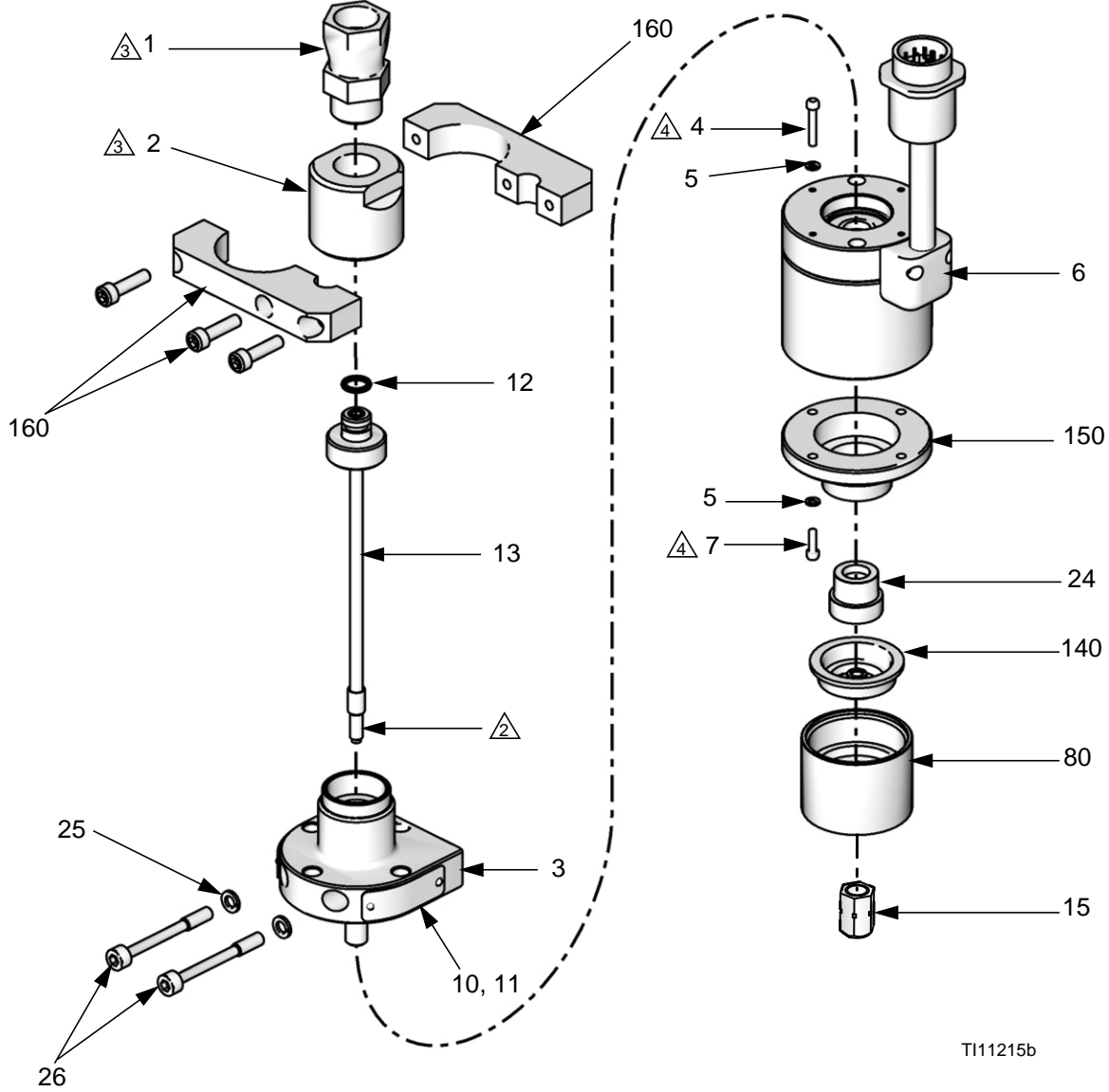

T111215b

- ⚠️ 1 Torque to 12-15 in-lb (1.36-1.69 N•m) maximum.
- ⚠️ 2 See Table 4 on page 22.
- ⚠️ 3 Torque to 17-20 ft-lb (22.95-27.0 N•m) maximum.
- ⚠️ 4 Torque to 16-18 ft-lb (21.6-24.3 N•m) maximum.

**Standard Version (243402 and 243403)**

Ref.	Part	Description	Qty.
1	617567	FITTING, union, swivel	1
2	617561	CAP, inlet	1
3	24X848	KIT, housing, upper, mount	1
4	C19953	SCREW, SHC; #4-40 x 0.75	4
5	C19208	WASHER, lock; #4	8
6	241479	MOTOR, assy	1
7	C19950	SCREW, SHC; #4-40 x 0.375	4
10	617626	PLATE, identification	1
11	617712	LABEL	1
12†✿	C20084	O-RING; -001; EPDM	1
13†✿	241465	TUBE, fluid	1
15**		NOZZLE	1
24a✿	243256	COUPLER, motor, assy 0.012 offset (includes tube bearing); 243402 only	1
24b†	241466	COUPLER, motor, assy 0.028 offset (includes tube bearing); 243403 only	1
25	100020	WASHER, lock	2
26	114135	SCREW, mounting, manifold	2
80	196038	GUARD, nozzle	1
117	101369	KIT, tool, allen wrench; not shown	2
140†✿	15B619	GUARD, coupler, sealant; fluoroelastomer	1
150	196037	HOUSING, lower	1
160	15D259	CLAMP, assy	1

† Also included in Kit 246292 (Wide Pattern Coupler Repair Kit).

✿ Also included in Kit 246293 (Narrow Pattern Coupler Repair Kit).

\*\* See Table 4 on page 22 for nozzle sizes and part numbers.

**Compact Version (289261 and 289262)**

Ref.	Part	Description	Qty.
1	617567	FITTING, union, swivel	1
2	617561	CAP, inlet	1
3	24X847	KIT, housing, upper, mount	1
4	C19953	SCREW, SHC; #4-40 x 0.75	4
5	C19208	WASHER, lock; #4	8
6	241479	MOTOR, assy	1
7	C19950	SCREW, SHC; #4-40 x 0.375	4
10	617626	PLATE, identification	1
11	617712	LABEL	1
12★◆	C20084	O-RING; -001; EPDM	1
13★◆	289263	TUBE, fluid	1
15**		NOZZLE	1
24a◆	243256	COUPLER, motor, assembly 0.012 offset (includes tube bearing); 289262 only	1
24b★	289531	COUPLER, motor, assembly 0.018 offset (includes tube bearing); 289261 only	1
25	100020	WASHER, lock	2
26	114135	SCREW, mounting, manifold	2
80	196038	GUARD, nozzle	1
117	101369	KIT, tool, allen wrench; not shown	2
140★◆	15B619	GUARD, coupler, sealant; fluoroelastomer	1
150	196037	HOUSING, lower	1
160	289519	CLAMP, assembly	1

★ Also included in Kit 289311 (Medium Pattern Coupler Repair Kit).

◆ Also included in Kit 289312 (Narrow Pattern Coupler Repair Kit).

\*\* See Table 4 on page 22 for nozzle sizes and part numbers.

# Accessories

## Motor Control Cable Assemblies

Table 2. Motor Control Cables

The motor control cables that are provided with the module are OLFLEX® brand cables. The 55 ft (16.8) motor cable (617870) can be used alone.

Part Number	Length	Description
617870	55 ft (16.8 m)	Motor cable assembly

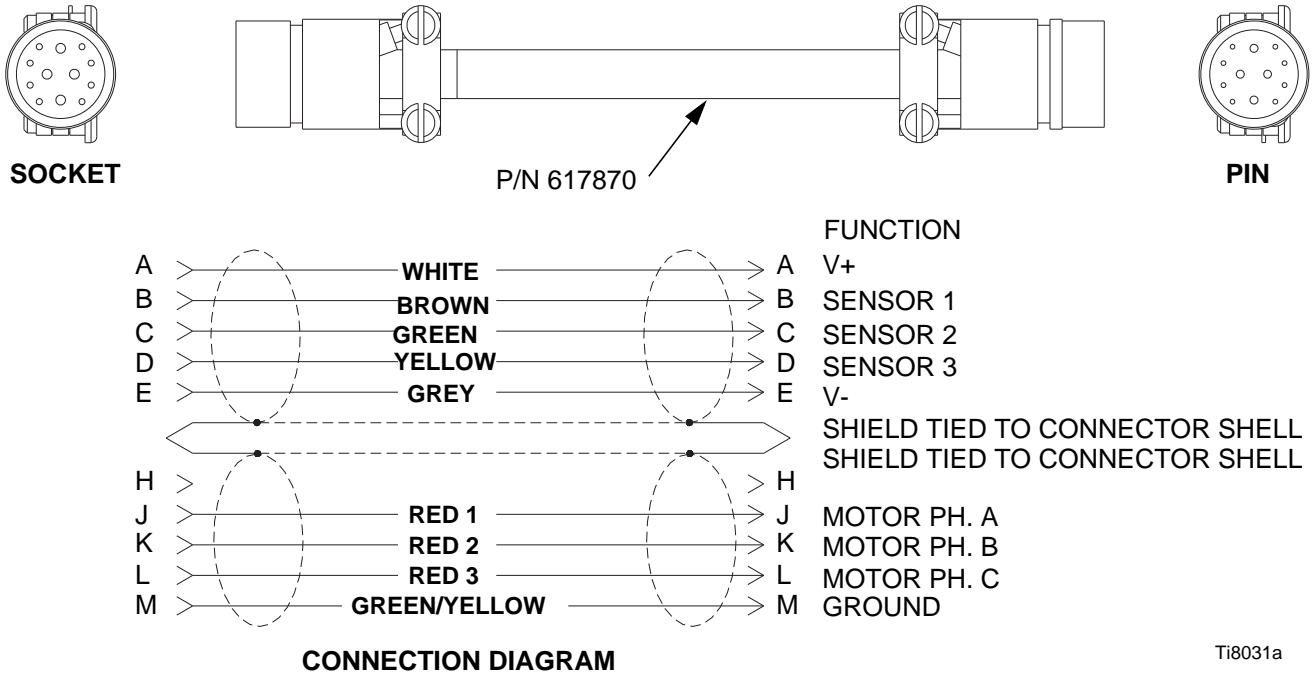

Fig. 8

## Torsional Motor Control Cable Assemblies

For robot applications that have a lot of torsional motion to the cable in addition to bending. These cables are made from Olflex 900 series robot cable that are designed to handle more torsional loads. The cables must be used in conjunction with the 55 ft motor cable.

Table 3. Motor Control Cables

Part Number	Length	Description
233125	6 ft (1.8 m)	Motor cable assembly
233124	9 ft (2.7 m)	Motor cable assembly
233123	15 ft (4.6 m)	Motor cable assembly

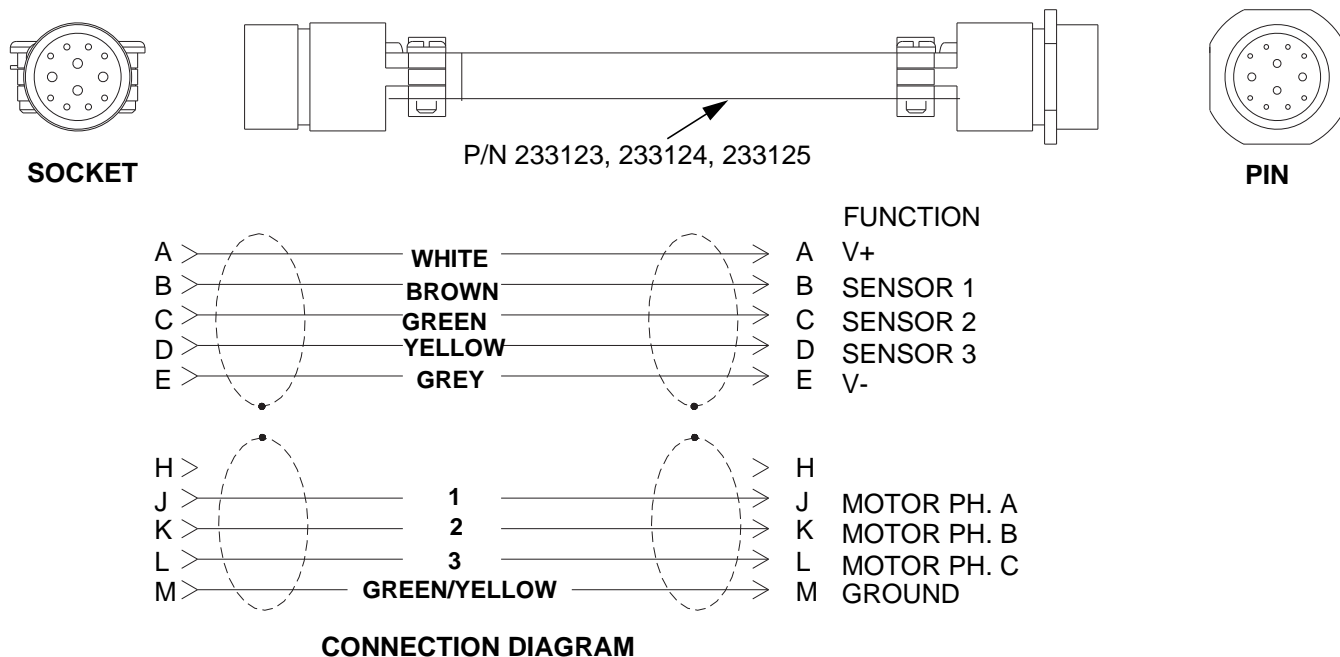

Fig. 9

## Orbital Dispenser Nozzles (15)

Table 4. Orbital Dispenser Nozzles

Nozzle Housing	Orifice Diameter
918610	0.012 in. (0.305 mm)
918601	0.015 in. (0.381 mm)
918603	0.019 in. (0.423 mm)
918605	0.023 in. (0.584mm)
918607	0.027 in. (0.686 mm)
918608	0.030 in. (0.762 mm)
918611	0.035 in. (0.889 mm)
918612	0.039 in. (0.991 mm)
918613	0.043 in. (1.092 mm)
918614	0.047 in. (1.194 mm)
241813	0.051 in. (1.295 mm)
241814	0.055 in. (1.397 mm)

## Bearing Repair Tool Kit 241569

Ref.	Part	Description	Qty.
1	617825	TOOL, push rod	1
2	617826	TOOL, coupling support	1
3	617828	TOOL, motor support	1
4	241517	TOOL, coupler puller	1
5	115740	TOOL, bearing puller	1
6	115741	ADHESIVE	1

## Bellows Seal Kits

### Kit 246290

Ref.	Part	Description	Qty.
1	15B619	SEAL; fluoroelastomer	12

## Recommended Dispense Valves

Dispense Valve	Part	Manual
1K Ultra-Lite™	243482	308876
EnDure® (Ambient or Water Conditioned)	244910	309376
EnDure® (120 Volt, Electric Heat)	244961	
EnDure® (230 Volt, Electric Heat)	244962	

## Dispense Valve Adapter Fittings

Ref.	Part	Description	Qty.
1	197504	ADAPTER, flange, straight, EnDure	1
2	197842	NOSEPIECE, 45 degree	1
3	198323	NUT, orbiter, alternative	1
4	198324	FITTING, nosepiece to orbiter	1

 The 45 degree orbiter mount uses reference numbers 2-4.

## Small Profile Retainer, 196039

Replaces the standard nozzle guard. This retainer has a smaller profile allowing easier access into tight locations.

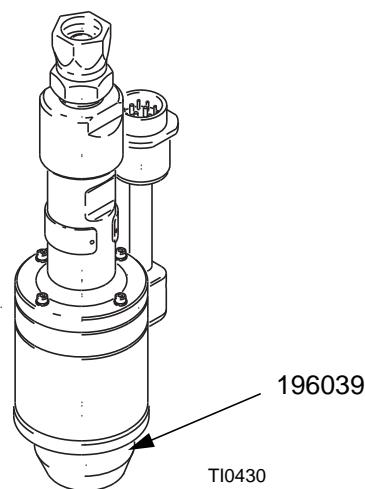

FIG. 10

# Dimensions

## Standard Version (243402 and 243403)

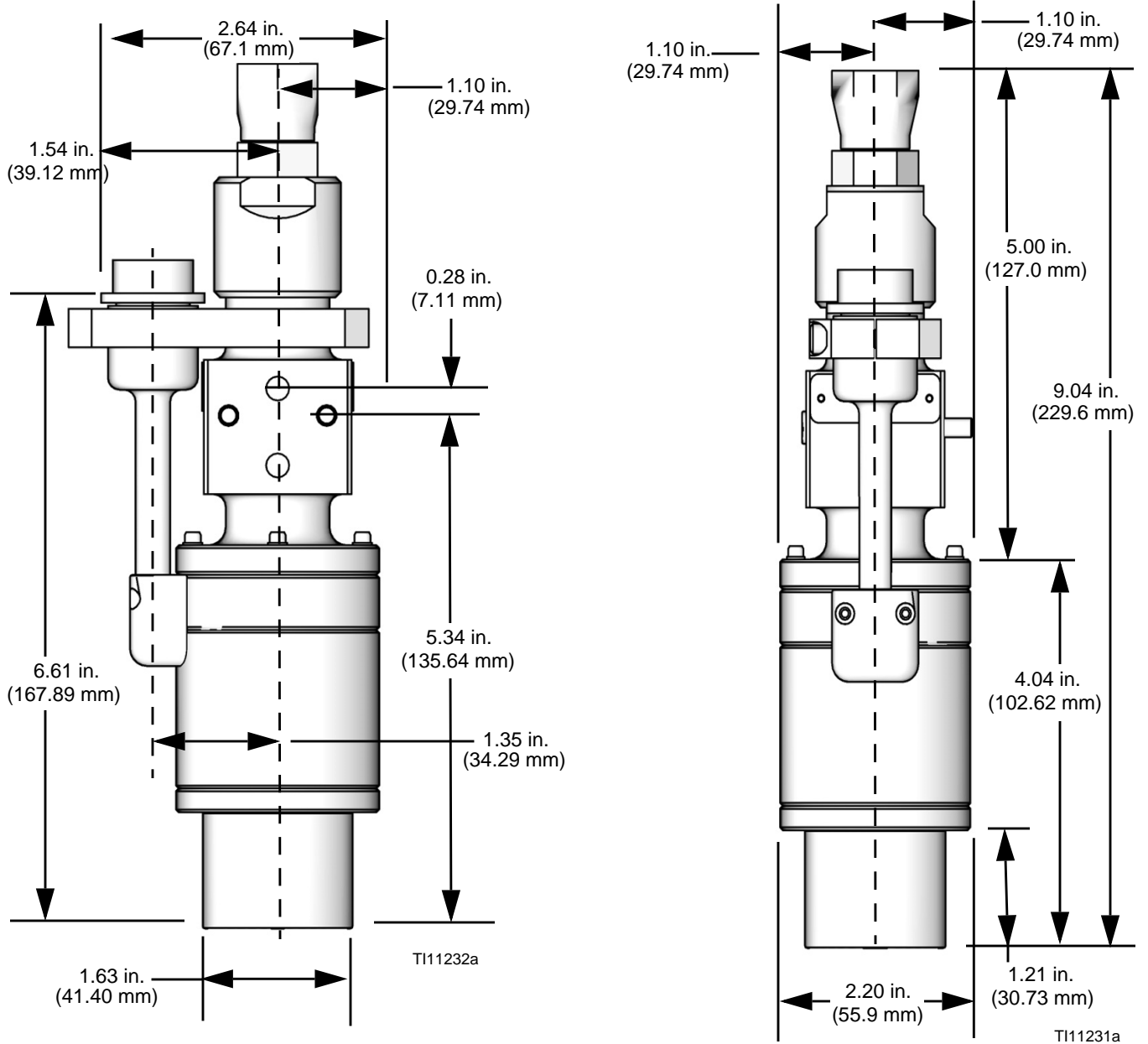

FIG. 11

### Compact Version (289261 and 289262)

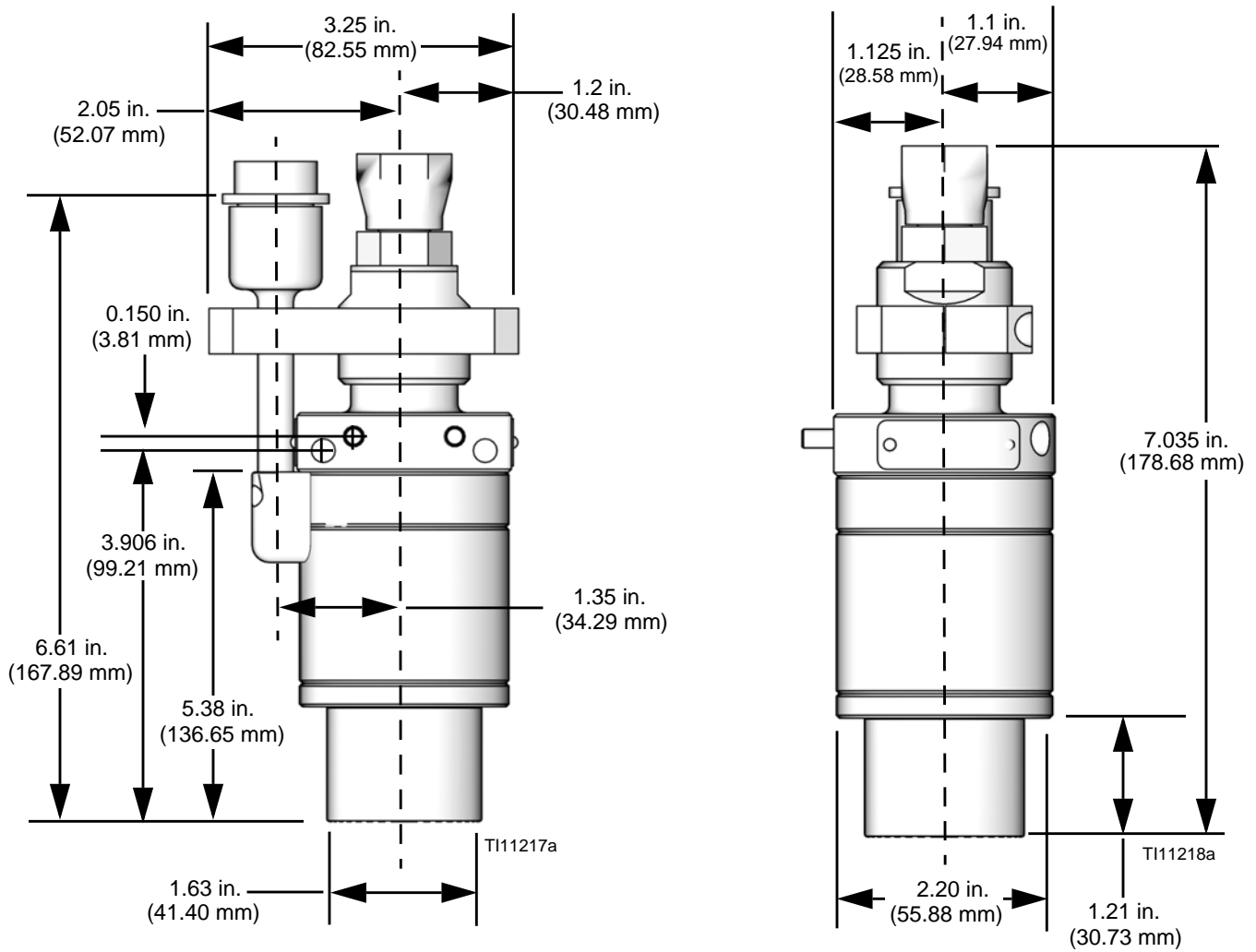

FIG. 12



# Technical Data

Input power . . . . .	Proprietary PWM voltage to motor, less than 24V
Motor torque . . . . .	1.5 oz-in.
Maximum motor speed . . . . .	24,000 RPM
Maximum operating pressure . . . . .	3500 psi (24.1 MPa, 241 bar)
Fluid inlet . . . . .	3/4-16 37° JIC female swivel
Nozzle attachment . . . . .	#10-32 proprietary connection
Wetted components . . . . .	Stainless steel, nickel alloy, brazing alloy, epoxy, EPDM rubber
Noise levels . . . . .	Sound pressure level - 67 dBa
Weight . . . . .	1.6 lb (0.7 kg)

*PrecisionSwirl™ is a trademark of Graco, Inc.*

*PARKER O LUBE™ is a trademark of Parker Hannifin Corp.*

*Loctite® is a registered trademark of the Loctite Corporation.*

# Graco Standard Warranty

Graco warrants all equipment referenced in this document which is manufactured by Graco and bearing its name to be free from defects in material and workmanship on the date of sale to the original purchaser for use. With the exception of any special, extended, or limited warranty published by Graco, Graco will, for a period of twelve months from the date of sale, repair or replace any part of the equipment determined by Graco to be defective. This warranty applies only when the equipment is installed, operated and maintained in accordance with Graco's written recommendations.

This warranty does not cover, and Graco shall not be liable for general wear and tear, or any malfunction, damage or wear caused by faulty installation, misapplication, abrasion, corrosion, inadequate or improper maintenance, negligence, accident, tampering, or substitution of non-Graco component parts. Nor shall Graco be liable for malfunction, damage or wear caused by the incompatibility of Graco equipment with structures, accessories, equipment or materials not supplied by Graco, or the improper design, manufacture, installation, operation or maintenance of structures, accessories, equipment or materials not supplied by Graco.

This warranty is conditioned upon the prepaid return of the equipment claimed to be defective to an authorized Graco distributor for verification of the claimed defect. If the claimed defect is verified, Graco will repair or replace free of charge any defective parts. The equipment will be returned to the original purchaser transportation prepaid. If inspection of the equipment does not disclose any defect in material or workmanship, repairs will be made at a reasonable charge, which charges may include the costs of parts, labor, and transportation.

**THIS WARRANTY IS EXCLUSIVE, AND IS IN LIEU OF ANY OTHER WARRANTIES, EXPRESS OR IMPLIED, INCLUDING BUT NOT LIMITED TO WARRANTY OF MERCHANTABILITY OR WARRANTY OF FITNESS FOR A PARTICULAR PURPOSE.**

Graco's sole obligation and buyer's sole remedy for any breach of warranty shall be as set forth above. The buyer agrees that no other remedy (including, but not limited to, incidental or consequential damages for lost profits, lost sales, injury to person or property, or any other incidental or consequential loss) shall be available. Any action for breach of warranty must be brought within two (2) years of the date of sale.

**GRACO MAKES NO WARRANTY, AND DISCLAIMS ALL IMPLIED WARRANTIES OF MERCHANTABILITY AND FITNESS FOR A PARTICULAR PURPOSE, IN CONNECTION WITH ACCESSORIES, EQUIPMENT, MATERIALS OR COMPONENTS SOLD BUT NOT MANUFACTURED BY GRACO.** These items sold, but not manufactured by Graco (such as electric motors, switches, hose, etc.), are subject to the warranty, if any, of their manufacturer. Graco will provide purchaser with reasonable assistance in making any claim for breach of these warranties.

In no event will Graco be liable for indirect, incidental, special or consequential damages resulting from Graco supplying equipment hereunder, or the furnishing, performance, or use of any products or other goods sold hereto, whether due to a breach of contract, breach of warranty, the negligence of Graco, or otherwise.

## **FOR GRACO CANADA CUSTOMERS**

The Parties acknowledge that they have required that the present document, as well as all documents, notices and legal proceedings entered into, given or instituted pursuant hereto or relating directly or indirectly hereto, be drawn up in English. Les parties reconnaissent avoir convenu que la rédaction du présente document sera en Anglais, ainsi que tous documents, avis et procédures judiciaires exécutés, donnés ou intentés, à la suite de ou en rapport, directement ou indirectement, avec les procédures concernées.

# Graco Information

For the latest information about Graco products, visit [www.graco.com](http://www.graco.com).

For patent information, see [www.graco.com/patents](http://www.graco.com/patents).

**TO PLACE AN ORDER**, contact your Graco distributor or call to identify the nearest distributor.

**Phone:** 612-623-6921 **or Toll Free:** 1-800-328-0211, **Fax:** 612-378-3505

*All written and visual data contained in this document reflects the latest product information available at the time of publication. Graco reserves the right to make changes at any time without notice.*

Original instructions. *This manual contains English. MM 309403*

**Graco Headquarters:** Minneapolis

**International Offices:** Belgium, China, Japan, Korea

**GRACO INC. AND SUBSIDIARIES • P.O. BOX 1441 • MINNEAPOLIS MN 55440-1441 • USA**

Copyright 2001, Graco Inc. All Graco manufacturing locations are registered to ISO 9001.

[www.graco.com](http://www.graco.com)

Revision M, March 2016