

EnDure™ Automatic Dispense Valves

309376J

EN

Air-operated dispense valves used for sealant and adhesive materials.

3500 psi (24.10 MPa, 241 bar) Maximum Dynamic Discharge Fluid Working Outlet Pressure

5000 psi (34.5 MPa, 345 bar) Maximum Static Working Pressure

120 psi (.83 MPa, 8.3 bar) Maximum Air Pressure



Important Safety Instructions

Read all warnings and instructions in this manual.
Save these instructions.

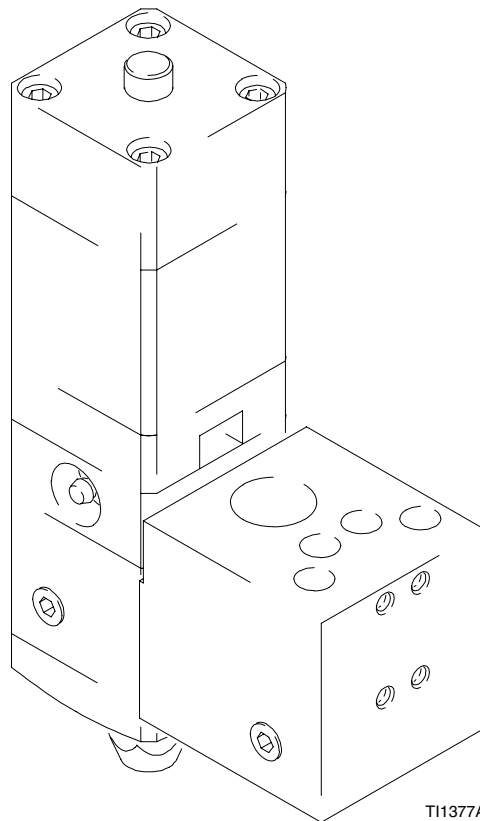

TI1377A

06540A

Table of Contents

List of Models	3	Parts	20
Warnings	4	Accessories	30
Installation	7	Dimensions	32
Maintenance	11	Technical Data	34
Troubleshooting	13	Wiring Diagram	35
Service	14	Graco Standard Warranty	36
		Graco Information	36

Models

Basic Valve Part No.	Complete Valve Part No.	Description (Replaces ...)	Maximum Fluid Temperature Rating C (F)	Heater Voltage Pin Connector	Wattage	Valve Outlet Connection	Parts Page
244535	244910	Valve, ambient or water conditioned. Replaces C27340 hard seat and 918512 soft seat snuff-back, if application is under 95 C (200 F).	95 C (200 F)	Nonpowered ambient or water circulation for temperature conditioning	0	5/8–18 male thread. Retainer nut with 1/8 npt(f)	29
	244961	Valve, 120 Volt E-Heat Replaces valve 194485. Any heated PrecisionFlo before XL (July 2001) if application is under 95 C (200 F).	95 C (200 F)	120 VAC 6 Pin round	150	5/8-18 male thread. Retainer nut with 1/8 npt(f)	27
	244962	Valve, 230 Volt E-Heat Replaces 243694 hard seat and 243696 soft seat snuff-back valves. Any Therm-O-Flow Plus (after July 2000) if application is under 95 C (200 F).	95 C (200 F)	230 VAC 8 Pin square	200	5/8-18 male thread. Retainer nut with 1/8 npt(f)	23
244907	244908	Valve, 120 Volt E-Heat Replaces C34068 hard seat, 918483 soft seat snuff-back, any Therm-O-Flow before Therm-O-Flow Plus (July 2000) if application is 95 C (200 F) to 204 C (400 F).	204 C (400 F)	120 VAC 6 Pin round	150	5/8-18 male thread. Retainer nut with 1/8 npt(f)	27
	244909	Valve, 230 Volt E-Heat Replaces 243694 hard seat and 243696 soft seat snuff-back valves. Any Therm-O-Flow Plus (after July 2000) if application is 95 C (200 F) to 204 C (400 F).	204 C (400 F)	230 VAC 8 Pin square	200	5/8-18 male thread. Retainer nut with 1/8 npt(f)	23
	297261	Complete Valve, 240 Volt E-Heat; Swirl Equipped	204 C (400 F)	240 VAC 8 Pin square	200	5/8-18 male thread with swirl adapter	
244937	244951	Valve, 230 Volt E-Heat Replaces valve 243695 hard seat with 1/2" npt (m) outlet. Any Therm-O-Flow before Therm-O-Flow Plus (July 2000) if application is 95 C (200 F) to 204 C (400 F).	204 C (400 F)	230 VAC 8 Pin square	150	1/2 npt (m)	23
	245184	Valve, 120 Volt E-Heat Replaces C34079 hard seat with 1/2" npt (m) outlet. Any Therm-O-Flow Plus (after July 2000) if application is 95 C (200 F) to 204 C (400 F).	204 C (400 F)	120 VAC 6 Pin round	200	1/2 npt (m)	27

Warnings

The following warnings are for the safe setup, use, grounding, maintenance, and repair of this equipment. The exclamation point symbol alerts you to a general warning and the hazard symbols refer to procedure-specific risks. Refer back to these warnings. Additional, product-specific warnings may be found throughout the body of this manual where applicable.

WARNING



INSTRUCTIONS



EQUIPMENT MISUSE HAZARD

Equipment misuse can cause the equipment to rupture, malfunction, or start unexpectedly and result in serious injury.

- This equipment is for professional use only.
- Read all instruction manuals, warnings, tags, and labels before operating the equipment.
- Use the equipment only for its intended purpose. If you are uncertain, call your Graco distributor.
- Do not alter or modify this equipment. Use only genuine Graco parts and accessories.
- Check the equipment daily. Repair or replace worn or damaged parts immediately.
- Do not exceed the maximum air working pressure of 1 MPa (8.3 bar, 120 psi) to the applicator.
- Do not exceed the maximum fluid working pressure of 24 MPa (241 bar, 3500 psi) to the applicator or manifold.
- Never exceed the recommended working pressure or the maximum air inlet pressure stated on your pump or in the **Technical Data** on page 34.
- Be sure that all spray/dispensing equipment and accessories are rated to withstand the maximum working pressure of the pump. Do not exceed the maximum working pressure of any component or accessory used in the system.
- Route hoses away from traffic areas, sharp edges, moving parts, and hot surfaces.
- Do not expose Graco standard hoses to temperatures above 180°F (82°C) or below -40°F (-40°C). Do not expose Graco electrically heated hoses to temperatures above 400°F (222°C) or below -40°F (-40°C).
- Do not use the hoses to pull the equipment.
- Use only fluids and solvents that are compatible with the equipment wetted parts. See the **Technical Data** sections of all the equipment manuals. Read the fluid manufacturer's warnings.
- Always wear protective eyewear, gloves, clothing, and respirator as recommended by the fluid and solvent manufacturers.
- Wear hearing protection when operating this equipment.
- Comply with all applicable local, state and national fire, electrical and other safety regulations.

WARNING



HOT SURFACE AND FLUID HAZARD

Heated fluid can cause severe burns and can cause equipment surfaces to become very hot.

- Wear protective gloves and clothing when operating this equipment in a heated system.
- Do not touch the metal heat sink when the surface is hot.
- Allow the equipment to cool thoroughly before servicing.

Some heated systems are designed to dispense Polyurethane (PUR) heated materials. PUR systems are supplied with ventilation hoods, and require proper ventilation and specially designed system components.

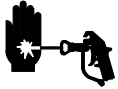

SKIN INJECTION HAZARD

Spray from the applicator, hose leaks, or ruptured components can inject fluid into your body and cause extremely serious injury, including the need for amputation. Fluid splashed in the eyes or on the skin can also cause serious injury.

- Fluid injected into the skin might look like just a cut, but it is a serious injury. **Get immediate surgical treatment.**
- Do not point the applicator at anyone or at any part of the body.
- Do not put hand or fingers over the front of the applicator.
- Do not stop or deflect fluid leaks with your hand, body, glove, or rag.
- Follow the **Pressure Relief Procedure** on page 14 whenever you are instructed to: relieve pressure; stop dispensing; clean, check, or service the equipment; or install or clean a tip or nozzle.
- Tighten all the fluid connections before operating the equipment.
- Check the hoses, tubes, and couplings daily. Replace worn, damaged, or loose parts immediately. Permanently coupled hoses cannot be repaired; replace the entire hose.
- ALWAYS wear eye protection and protective clothing when installing, operating, or servicing this dispensing equipment.
- Do not remove or modify any part of the applicator; this can cause a malfunction and result in serious bodily injury.
- Use extreme caution when cleaning or changing tips. If the tip clogs while applying material, ALWAYS follow the **Pressure Relief Procedure** on page 14, then remove the tip to clean it.
- NEVER wipe off build-up around the tip or air cap until pressure is fully relieved.

WARNING



FIRE, EXPLOSION, AND ELECTRIC SHOCK HAZARD

Improper grounding, poor air ventilation, open flames, or sparks can cause a hazardous condition and result in fire or explosion and serious injury.

- Ground the equipment and the object being sprayed. The Heated Automatic Dispense Valve is grounded to true earth ground inside the electrical control panel. See **Grounding** on page 9.
- Ground the equipment and the object being sprayed, and all other electrically conductive objects in the dispense area. Proper grounding dissipates static electricity generated in the equipment. See **Grounding** on page 9.
- Do not use this equipment with flammable liquids.
- Keep the dispense area free of debris, including solvent, rags, and gasoline.
- If there is any static sparking or you feel an electric shock while using the equipment, **stop dispensing immediately**. Do not use the equipment until you have identified and corrected the problem.
- Make sure all electrical work is performed by a qualified electrician only.
- Have any checks, installation, or service to electrical equipment performed by a qualified electrician only.
- Make sure all electrical equipment is installed and operated in compliance with applicable codes.
- Make sure power is disconnected when servicing and repairing equipment.
- Before operating the equipment, extinguish all open flames or pilot lights in the dispense area.
- Do not smoke in the dispensing area.
- Keep liquids away from the electrical components
- Disconnect electrical power at the main switch before servicing the equipment.
- Never exceed maximum wattage of the supply unit.



TOXIC FLUID HAZARD

Hazardous fluids or toxic fumes can cause serious injury or death if splashed in the eyes or on the skin, swallowed, or inhaled.

- Provide fresh air ventilation to avoid the buildup of vapors from the fluid being dispensed.
- Know the specific hazards of the fluid you are using.
- Store hazardous fluid in an approved container. Dispose of hazardous fluid according to all local, state and national guidelines.
- Always wear protective eyewear, gloves, clothing and respirator as recommended by the fluid and solvent manufacturer.
- Avoid exposure to heated material fumes.

Installation

Install the automatic applicator as follows:

- mount the automatic dispense valve
- attach dispense tip or nozzle
- connect the air lines
- connect material hose
- if heated, connect the electrical cable
- if temperature conditioned, connect the water circulation
- make sure the automatic dispense valve is grounded

Mount the Automatic Dispense Valve

Mount the automatic dispense valve to the mounting bracket on a stationary support or robotic arm (Fig. 1), using two M6x1.0 socket head screws and two flat washers. If your application is heated, be sure to position the insulation block between the dispense valve and the mounting bracket, (Fig. 2). Refer to the dimensions on page 32.

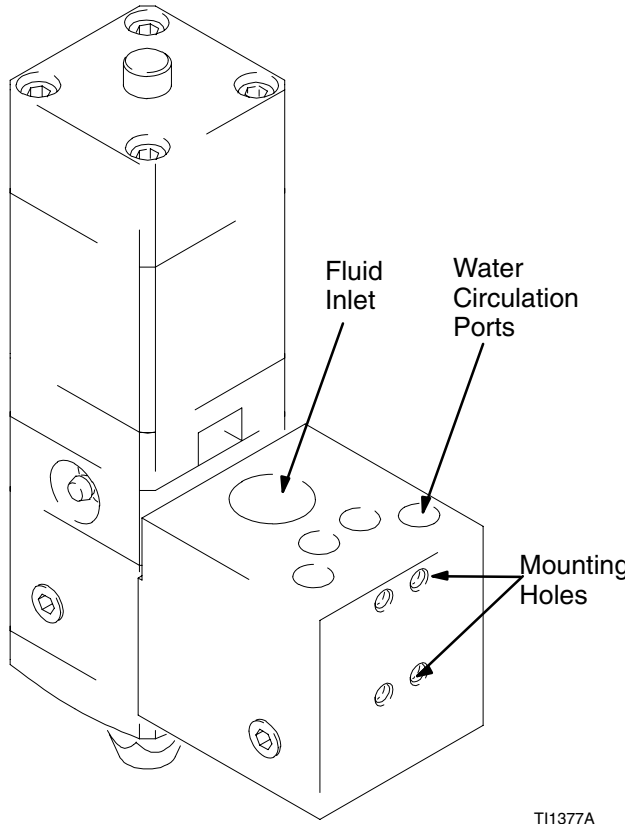

Ambient or temperature conditioned model shown

Fig. 1

Installation

Connect Air Lines to Dispense Valve

⚠ CAUTION

Only use air fittings that are rated at a temperature equal to or higher than the operating temperature of your fluid dispensing system. Lower rated air fittings could melt and cause damage to the automatic dispense valve.

These valves are air to open and air to close with a spring to bias them closed. Use a 4-way exhausting solenoid to operate these valves.

Be sure to connect the appropriate air lines to the appropriate ports (Fig. 2), and securely connect air lines to dispense valve air ports. See page 32.

Connect Material Hose to Dispense Valve

Securely connect the material hose to the dispense valve material inlet port. See Fig. 2.

Connect Electrical Cable to Electrically Heated Dispense Valves

Connect electrical cable plug from your Therm-O-Flow, Therm-O-Flow Plus, or PrecisionFlo hose or control. A six-pin round connector is used on 120 volt valves and an eight-pin square connector is used on 240 volt valves.

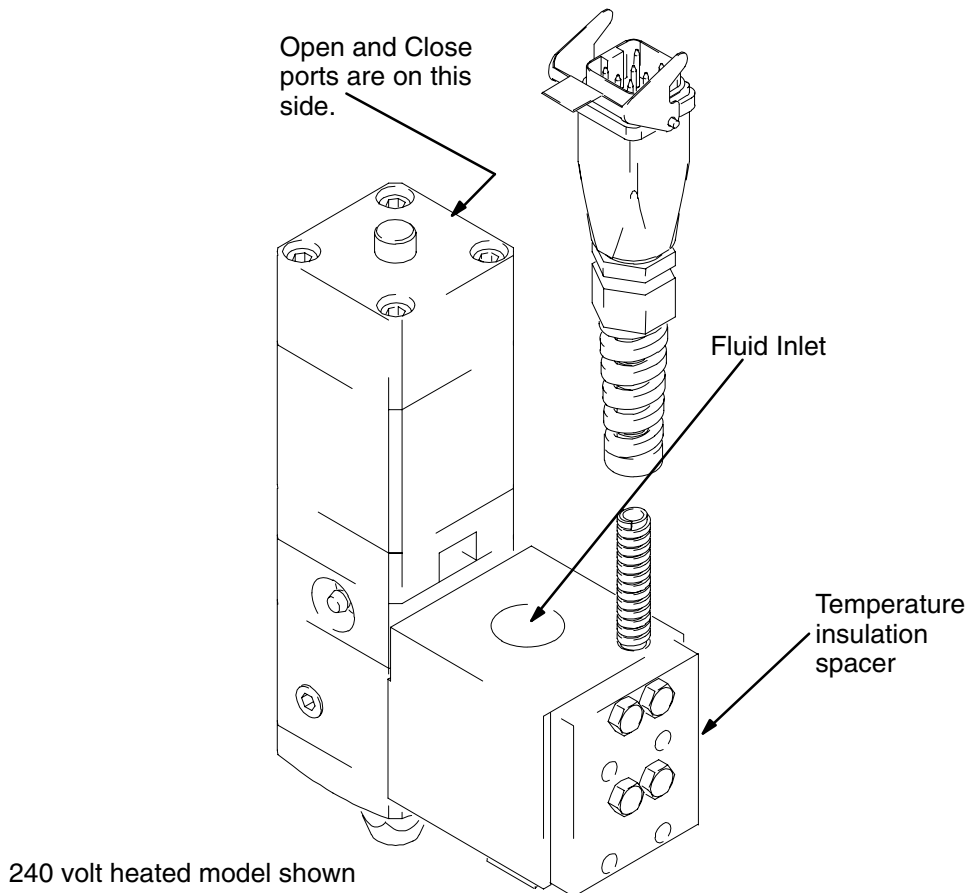



Fig. 2

Installation

Grounding

⚠ WARNING



FIRE, EXPLOSION, AND ELECTRIC SHOCK HAZARD

To reduce the risk of fire, explosion, or electric shock:

- The power source conduit is not an adequate ground for the system. The unit must be grounded to either the building ground or a true earth ground.
- A qualified electrician must complete all grounding and wiring connections and check the resistance.

- Refer to your local code for the requirements for a “true earth ground” in your area.
- Also read and follow the warnings on page 6.

Electrically Heated Models.

Ground the automatic dispense valve:

1. Connect the connector from a heated hose to the receptacle on the dispense valve.

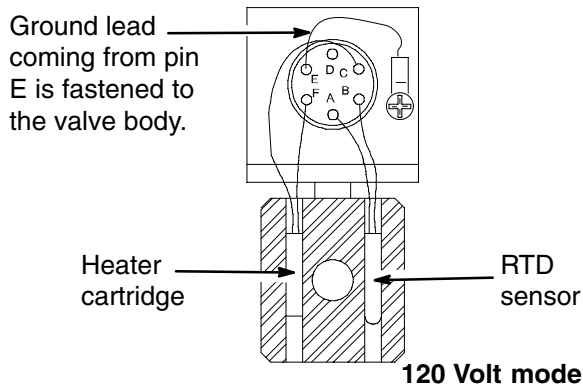

Fig. 3

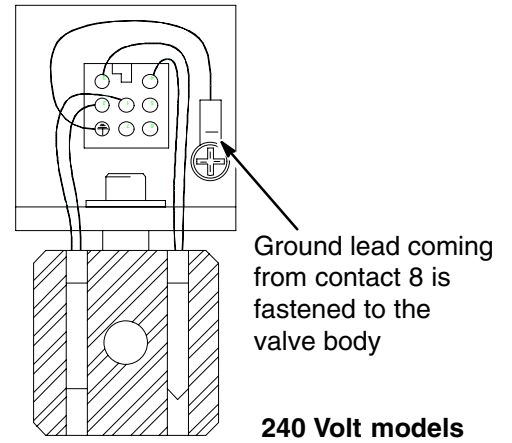

Fig. 4

T10305

2. Connect the electrical cable to the electrical control panel.
3. Verify that socket contact E on six pin models (see Fig. 5) or contact eight on eight pin models (see Fig. 4) , inside control panel receptacle, is connected to true earth ground.

See page 35 for schematics.

Snuff-Back

Snuff-back is created when the needle is pulled back through a restrictive ring before it closes against the carbide seat.

For maximum snuff-back, leave the ring in place. For maximum flow with less snuff-back, remove the ring. For additional snuff-back, use a quick exhaust valve (104661) on the “open” air port.

Nozzle selection and gun movement also effect fluid cut-off characteristics.

Installation

Connecting the Electrical Cable from a Therm-O-Flow Plus Heated Hose

1. Wrap the hose cable around the hose one time. Connect the electrical cable from the hose to the valve cable; lock the metal clip on the top of the connector. See Fig. 5.
2. Place the flat side of the cable connection against the hose, making sure the metal clip faces away from the hose. This will prevent damage to the hose from the clip rubbing against it. See Fig. 6.
3. Secure the cable connector to the hose with heavy tape or Velcro straps. For installations where the dispense valve is moving, it is recommended that the connector be wrapped with the Graco accessory Velcro wrap (198422) and 2 Velcro straps (198442) as shown in Fig. 7.



Fig. 5

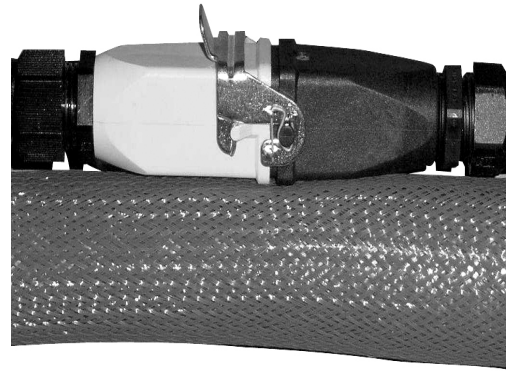

Fig. 6



Fig. 7

Maintenance

The following tables list recommended maintenance procedures and frequencies. The maintenance is divided between mechanical and electrical tasks. A typical application is a valve mounted on a robot dispensing a moderately abrasive sealant.

Mechanical

Task	Daily	Weekly	Monthly or 30,000 cycles	3-6 months or 125,000 cycles	6-12 months or 250,000 cycles	18-24 months or 500,000 cycles	36-48 months or 1,000,000 cycles	6-8 years or 2,000,000 cycles
Inspect for leaks		✓						
Check hoses for wear*		✓						
Check/tighten fluid connections*		✓						
Check/tighten air connections*		✓						
Lube packings			✓					
Rebuild dispense valve					✓			
Replace valve								✓
* Assumes movement from automation.								

Electrical

Task	Daily	Weekly	Monthly	6 Months	12 Months
Check cables for wear		✓			
Verify cable connections		✓			
Verify resistance of electric heaters			✓		
Verify resistance of RTD sensors			✓		

Packing Lubrication

This valve has a primary seal, a pressurized grease area, and a secondary seal. The key to long seal life is that the secondary seal only has to seal grease.

When dispensing filled materials this grease should be refreshed once a month.

1. Remove one of the zerk grease fittings (23).
2. Using the grease gun supplied, pump a high quality grease like #115982 (high temperature moisture free) into the remaining zerk fitting until fresh grease comes out the other side.
3. Replace the grease fittings and give the valve one more shot of grease to pressurize the cavity.

Maintenance

Factors affecting valve life

The maintenance tables should be used as a guideline for frequency of maintenance tasks. Additional factors that affect valve life include the following:

- **Process fluid** – Abrasive or fiber filled fluids are much harder on seals, shafts, and seats than non-abrasive fluids such as oil.
- **Pressure drop across the valve seat** – As the valve opens or closes, the fluid is accelerated to a high velocity at the needle/seat contact area. The rate of wear at the valve will be much greater at 3000 psi than at 1000 psi. Changing nozzle or tip size can have a substantial affect on wear.
- **Number of cycles** – This has a much greater affect on valve wear than number of gallons. If you can do the same job with fewer on/off cycles, the valve will last longer.
- **Speed of actuation** – Snapping the valve open and closed quickly will give longer needle and seat life. Avoid long air tube runs after the solenoid, or use quick exhaust valves (104661) on the dispense valve.
- **Air pressure** – This is what provides the force to hold the hardened SST needle against the carbide seat to seal against fluid pressure. Any leakage on these hard parts, at high pressure, will quickly “worm-hole” the parts and cause the valve to fail. This valve has been designed with two air pistons to give it an exceptionally high, 68:1 advantage of air pressure to fluid pressure. This means that you can reliably operate at 60 psi of air, even with 4000 psi of downstream pressure.

Troubleshooting

Some solutions require disassembling the automatic dispense valve. Always relieve system pressure before performing these procedures.

⚠ WARNING



To reduce the risk of serious injury whenever you are instructed to relieve pressure, always follow the **Pressure Relief Procedure** (page 14).

See PARTS section for the parts that need to be serviced.

Problem	Cause(s)	Solution(s)
Air leaks from automatic dispense valve	Loose air connections	Check air connections.
	Worn o-rings	Replace o-rings in cylinder.
Material leaks from front of automatic dispense valve	Seal, needle, or seat is worn	Replace seat seals (12 & 26), needle (7), and seat (13).
	Obstruction inside dispense valve	Remove nose piece (6). Check and replace if necessary, seals (12 & 26), needle (7), and seat (13).
	Worn needle	Check and replace needle (7), if necessary. If replacing needle, you must reverse or replace seat (13).
	Worn seat (Base seal models)	Check and replace or reverse seat (13) if necessary. Replace needle (7) with seat (13).
Material leaks from automatic dispense valve body	Seal not installed correctly	Check seals (15 & 16) and replace if necessary.
	Seal is worn	
Automatic dispense valve does not shut off	Loose air connections	Check air connections.
	Worn needle-seal interface	Replace rod seal (12 & 26), needle (7), and seat (13).
Automatic dispense valve does not shut off	Broken retaining ring (10) or debris in air cylinder.	Disassemble dispense valve. Check and replace, if necessary, retaining ring (10) and o-rings (17, 18, 19 and 21).
Automatic dispense valve does not shut off	Spring broken or not installed correctly	Disassemble dispense valve. Check spring (24) and replace, if necessary.
Automatic dispense valve does not heat material	Loose heater wires	Check and reconnect wire connections.
	Loose sensor wires	Check and reconnect wire connections.
	Heater unit failed	Replace heater.
	Sensor failed	Replace sensor.
	Temperature controller failed	Replace temperature controller.
	No power to heating circuitry	Apply power to heating circuitry.
Automatic dispense valve will not open	Fluid pressure in outlet line greater than 24.1 MPa (241 bar, 3500psi)	Reduce outlet restrictions
		Reduce fluid pressure
	Air cylinder pressure too low	Increase air pressure

Service

Pressure Relief Procedure

WARNING



HOT SURFACE AND FLUID HAZARD

The material and equipment will be hot! To reduce risk of injury, wear eye protection, gloves and protective clothing when installing, operating, or servicing this dispensing system.



SKIN INJECTION HAZARD

The system pressure must be manually relieved to prevent the system from starting or spraying accidentally. Fluid under high pressure can be injected through the skin and cause serious injury. To reduce the risk of an injury from injection, splashing fluid, or moving parts, follow the **Pressure Relief Procedure** whenever you:

- are instructed to relieve the pressure
- stop spraying/dispensing
- install or clean the nozzle
- check or service any of the system equipment



PRESSURIZED FLUID HAZARD

High pressures can cause serious personal injury. Be sure to **open the dispense valve during system heat-up** to alleviate pressure which might occur in the system due to material expansion.

This procedure describes how to relieve pressure from the automatic dispense valve. See your supply unit or system documentation for instructions on relieving pressure for the entire dispensing system. Use this procedure whenever you shut off the dispense valve and before checking or adjusting any part of the system, to reduce the risk of serious injury.

1. Shut off the material supply.
2. If heated, shut off electrical power to the automatic dispense valve.
3. Close all self bleeding air supply valves for supply unit.
4. Have a container ready to catch the drainage, then bleed off material pressure by actuating the dispense valve.
5. Shut off air supply to valve.

NOTE: *If you suspect that the nozzle or hose is completely clogged, or that pressure has not been fully relieved after following the steps above, **very slowly** loosen the tip retaining nut or hose end coupling to relieve pressure gradually, then loosen completely. Then clear the tip/nozzle or hose.*

Service

Prepare to Service Automatic Dispense Valve

If the unit is hot, determine whether or not you can service the unit after it has cooled down. Some materials, like polyurethanes, may cure permanently when cooled and exposed to air, preventing you from disassembling the dispense valve. If you are working with such a material, service the unit while the material is at a temperature where the material is soft enough to work with. If the material can be reheated at a later time, you can service the unit after it has cooled, reheating the material as necessary.

Perform this procedure before servicing the automatic dispense valve.

1. **Relieve the system pressure.**

WARNING

To reduce the risk of serious injury, whenever you are instructed to relieve pressure, always follow the **Pressure Relief Procedure** (page 14).

2. Make sure material flow has been shut off.
3. Make sure system air has been shut off.

4. Remove power from the automatic dispense valve.

WARNING



HOT SURFACE AND FLUID HAZARD
The material and equipment will be hot! To reduce risk of injury, wear eye protection, gloves and protective clothing when servicing this dispensing system component.

5. If the material in the dispense valve can be reheated, wait for the dispense valve to cool thoroughly before servicing it.

If the material in the dispense valve cures permanently when cooled and/or exposed to air, service the unit while the material is at a temperature where the material is soft enough to work with.

Service

Service the Automatic Dispense Valve

The dispense valves can be serviced or replaced without disconnecting the fluid hose or temperature control cables or tubes.

Disconnect Automatic Dispense Valve from its Inlet Manifold

Remove the automatic dispense valve from its mounting bracket.

1. Perform the procedures in **Prepare to Service Automatic Dispense Valve** on page 15.

⚠ WARNING

HOT SURFACE AND FLUID HAZARD
The material and equipment may be hot! To reduce risk of injury, wear eye protection, gloves and protective clothing when servicing this dispensing system component.

2. Disconnect air lines from dispense valve air ports.
3. Remove 4 M-6 socket head screws that connect the valve body to the inlet manifold. (see Fig. 8.)
4. Pull the valve body straight away from the inlet manifold.

Reconnect Automatic Dispense Valve to Mounting Bracket

1. Install new o-ring on fluid passage and water passages if used.
2. Line up valve body with locating pins and heater and sensor if used.
3. Push valve straight on to pins. Torque retaining screws evenly to 50-60 in/lb.
4. Reconnect air lines to dispense valve air ports.

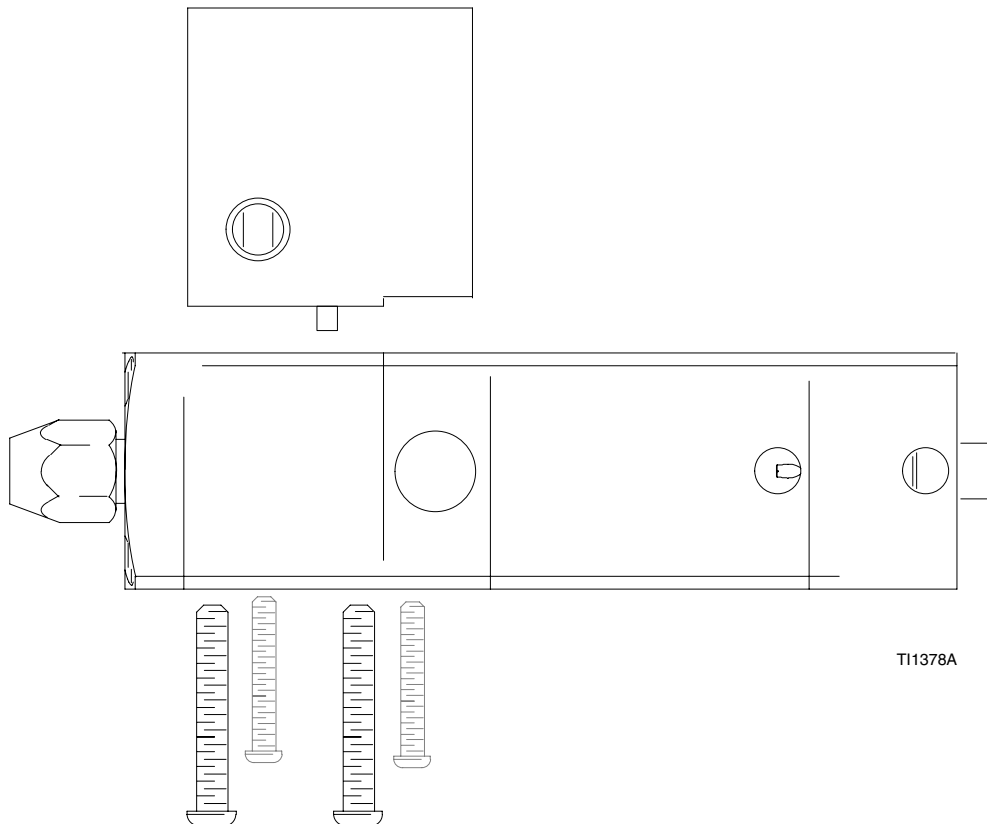

Fig. 8

Service

Valve models 244535, 244907, and 244937

NOTE: See parts drawing on page 20 for parts referenced in parentheses ().

Disassemble Automatic Dispense Valve

NOTE: The fluid section and the air section can be serviced independently.

Fluid Section

1. Remove 4 screws (22) and pull the nose piece (6) straight off.
2. Insert a 3/32 punch or an allen wrench through the hole in the head of the needle (7) and unscrew from shaft (8). Another punch can be used through the hole in shaft (8) to keep it from turning.
3. Remove seat (13) and gasket (12).

4. Pull fluid housing (5) and grease bearing housing (4) from the shaft.

Air Section

1. Remove 4 screws (22) from top of valve. Pull top air cylinder housing (1) straight off.
2. Remove the first retaining ring (10), piston (9), and second retaining ring (10).

NOTE: Use only the new retaining rings provided in repair kit when reassembling air section of valve.

3. Pull lower air cylinder housing (2) straight away from housing (3)
4. Remove shaft (8) if fluid section has been disassembled.

Service

Assembly of Automatic Dispense Valve Valve models 244535, 244907, and 244937

NOTE: See parts drawing on page 20 for parts referenced in parentheses (). See service drawing on page 19 for references to steps in this procedure [x].

Air Section

1. Lubricate all seals and sliding parts with a high temperature, moisture free grease such as the #115982 grease cartridge provided with the valve.
2. Assemble o-rings (17), (19), and (21) into or onto their respective parts as shown. Install o-ring (18) only to housing (3).
3. Insert shaft (8), (small end first) into housing (3).

NOTE:

- Do not overextend retaining ring (10) during installation and repair.
- Make sure to assemble retaining ring longitudinally down the shaft diameter.
- Do not stretch the ring around the diameter.
- Use only the new retaining rings provided in repair kit when reassembling air section of valve.

4. Assemble the lowest retaining ring (10) on the shaft. Add o-ring (18) onto the shaft, then add spring (24), a piston (9), and the next retaining ring (10).
5. Slide housing (3) straight down over shaft (8) with pieces aligned as shown.
6. Add next retaining ring (10), o-ring (18), piston (9), and last retaining ring (10).
7. Insert button (33) into housing (1) and push assembly down over the piston and shaft.
8. Align the open/close air ports as shown.
9. Insert four screws (22) and torque evenly to 40-50 lb-in.

Fluid Section

10. Lubricate all seals and sliding parts with a high temperature, moisture free grease such as the #115982 grease cartridge provided with the valve.
11. Carefully insert "U" cup (15) into bearing (11) with the open end of the seal facing into the bearing. Install o-ring (21) on the outside groove of the bearing.
12. Insert the bearing, "U" cup end first, into the grease housing (4). Push this assembly onto shaft (8) while holding bearing (11) into housing (4).
13. Carefully insert "U" cup (16), lips first, into the appropriate end of housing (5). Push this assembly onto shaft (8), up against housings (3) and (4).
14. Place the valve in a vice such that it is pushing button (33) to compress the spring.
15. Place the clear plastic gasket (12) and seat (13) into their groove on housing (5). The seat is reversible and can go in either way.
16. Insert needle (7) through seat (13). While holding shaft (8), screw the needle (7) into shaft (8) using Loctite blue thread locker. Tighten with a 3/32 pin or punch to approximately 15-20 lb-in.
17. Place snuff-back ring (14) in nose piece (6) and white o-ring (26) in its groove on housing (5). Align nose piece (6) and push straight into place. If higher flow and less snuff-back is desired, do not use the snuff-back ring (14).
18. Insert four screws (22) with Loctite blue thread locker and tighten evenly, compressing bearing (11) to 40-45 lb-in.
19. Cycle valve 25 times at full air pressure to set hardened needles to carbide seat.
20. Install one fitting (23). Pump grease (27) across bearing (11) and out other side. Install second fitting (23) and apply another shot of grease.
21. Use pipe thread sealant on plugs (36 and 35).

Service

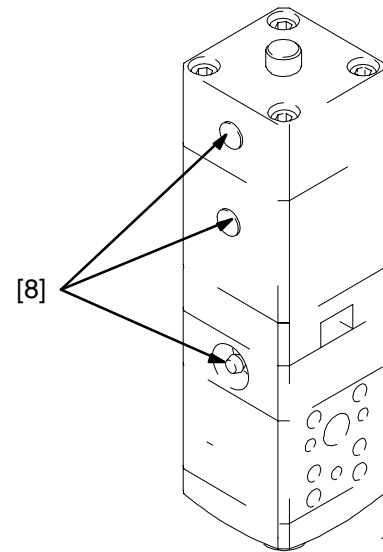
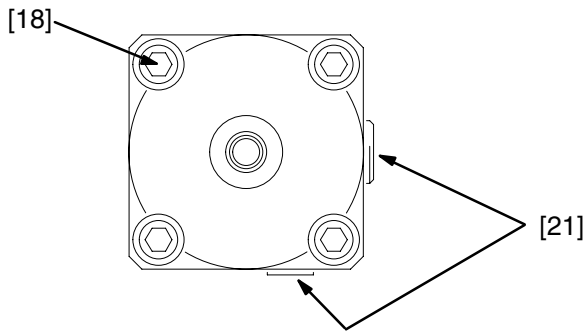
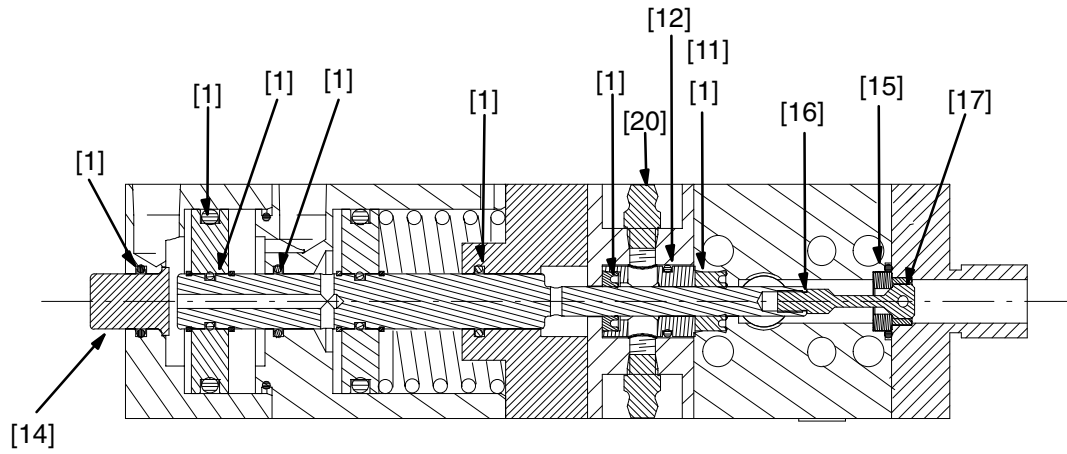

[x] Refers to instruction steps from procedure on page 18.

T11379A

Fig. 9

Parts

Model numbers 244535, 244907, and 244937

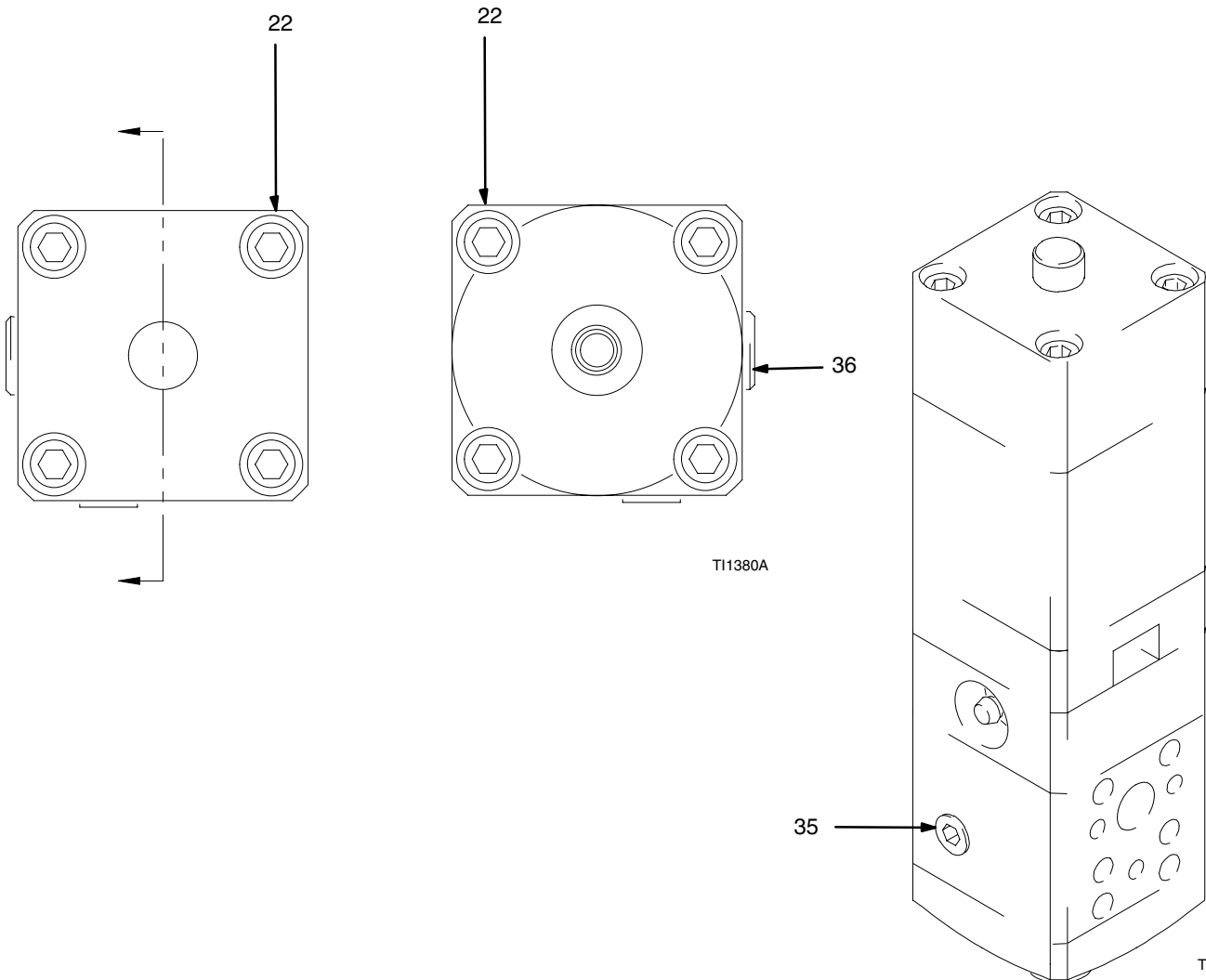
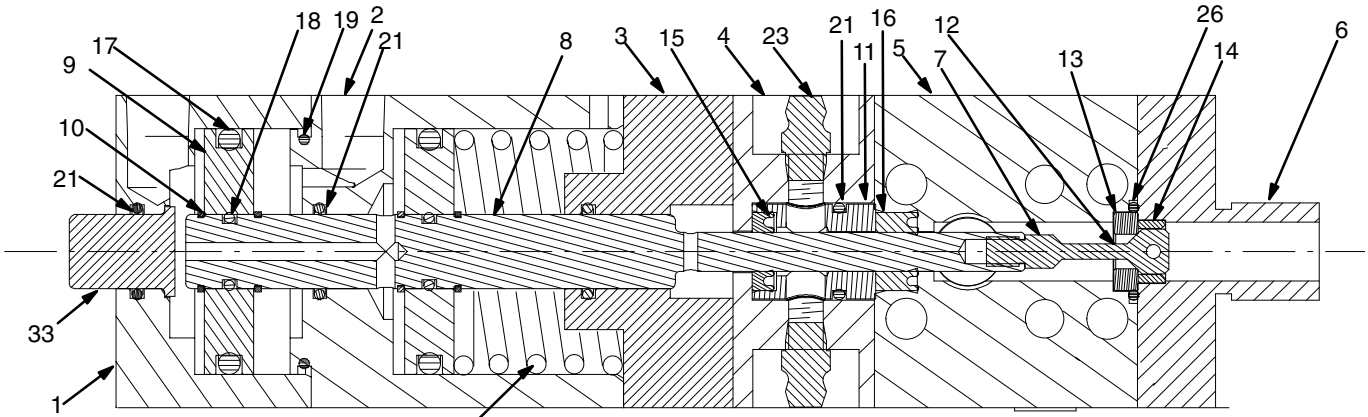

Parts

Model numbers 244535, 244907, and 244937

Ref No.	Part No.	Description	Qty.	Ref No.	Part No.	Description	Qty.
1	197506	CYLINDER, valve	1	16**	551190	SEAL, u-cup polymt 1/4, 1/2, 1/4 (model 244535)	1
2	197509	CYLINDER, air, top	1	16**	551193	SEAL, u-cup PTFE 1/4, 1/2, 1/4 (models 244907 and 244937)	1
3	197508	HOUSING, cylinder, air	1	17**	116978	PACKING, o-ring, fluoroelastomer	2
4	197503	HOUSING, lubrication	1	18**	106555	PACKING, o-ring, fluoroelastomer	2
5	197505	HOUSING, material	1	19**	102895	PACKING, o-ring, cylinder, fluoroelastomer	1
6	198280	FLANGE, nose piece (models 244535 and 244907)	1	21**	103610	PACKING, o-ring, fluoroelastomer	4
6	198443	FLANGE, nose piece (model 244937)	1	22	111112	SCREW, cap, socket head	8
7**	626062	NEEDLE, sst hardened	1	23**	100846	FITTING, lubtn, st	2
8	15E014	SHAFT, valve	1	24	111092	SPRING, valve	1
9	111094	PISTON	2	26**	104319	PACKING, o-ring	1
10**	15E017	RING, retaining, external	4	27*	115982	LUBRICANT, synthetic, grease	1
11**	626064	BEARING, lube	1	28*	551189	GUN, grease, 3 oz. cartridge	1
12**	171860	GASKET, seat	1	33	198234	BUTTON, valve	1
13**	185467	SEAT, valve	1	35	101970	PLUG, pipe, headless	1
14**	626060	INSERT, snuff-back	1	36	110208	PLUG, pipe, headless	1
15**	551191	PACKING, u-cup Fluoroelastomer 1/4, 1/2, 1/8 (model 244535)	1				
15**	617491	PACKING, u-cup urt 1/4, 1/2, 1/8 (models 244907 and 244937)	1				

* not shown
 ** Included in repair kits. Kits also include manifold o-rings for all models.

NOTE: Do not overextend retaining rings (10) during installation and repair.

Repair Kits

Part No.	Description
15E012	Standard seals
15E011	High temperature seals

Parts

Models 244962, 244909, and 244951 (240 V. Models)

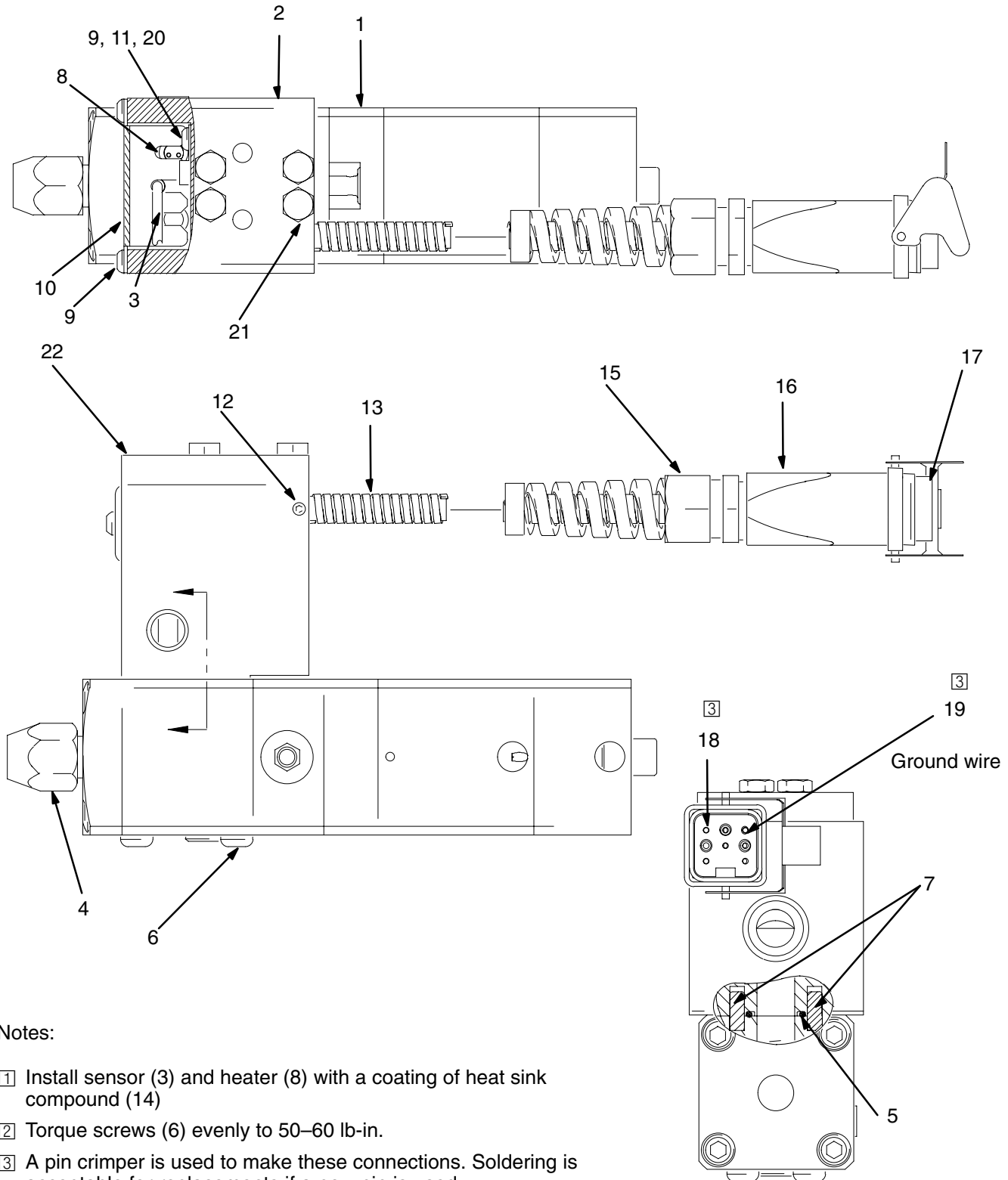

Notes:

- ① Install sensor (3) and heater (8) with a coating of heat sink compound (14)
- ② Torque screws (6) evenly to 50–60 lb-in.
- ③ A pin crimper is used to make these connections. Soldering is acceptable for replacements if a new pin is used.

T11382A

Parts

Models 244962, 244909, and 244951 (240 V. Models)

Ref No.	Part No.	Description	Qty.	Ref No.	Part No.	Description	Qty.
1	244535	VALVE, ext, dispense, 200 deg. F (model 244962)	1	11	101674	TERMINAL, ring, ground	1
1	244907	VALVE, ext, dispense, 400 deg. F (model 244909)	1	12	105672	SCREW, set, sch.	1
1	244937	VALVE, (model 244951)	1	13	116675	CORD, flex,	1
2	198236	MANIFOLD, electrical	1	14*	073019	LUBRICANT, thermal	1
3	C32255	SENSOR, temperature	1	15	116673	BUSHING, strain relief	1
4	C32089	RETAINER, nozzle	1	16	116637	CONNECTOR, cable coupler hood	1
5**	109576	PACKING, o-ring, fluoroelastomer	1	17	115860	INSERT, male	1
6	116412	SCREW, cap, button head, M6 x 60	4	18	116640	CONTACT, connector	4
7	114618	PIN, dowel, dia. 3/16 x 1/2 lg	2	19	115862	CONNECTOR, male, crimp	1
8	116614	HEATER, cartridge, 240 V	1	20	065345	WIRE, copper, electrical (16 AWG)	2 ft.
9	114185	SCREW, cap, button head	3	21	513035	SCREW, cap, shcs	4
10	198232	GUARD, manifold,	1	22	197843	Block, mounting	1

* not shown

** Included in repair kits. Kits also include manifold o-rings for all models.

Repair Kits

Part No.	Description
15E012	Standard seals
15E011	High temperature seals

Parts

Model 297261 (240 V Model)

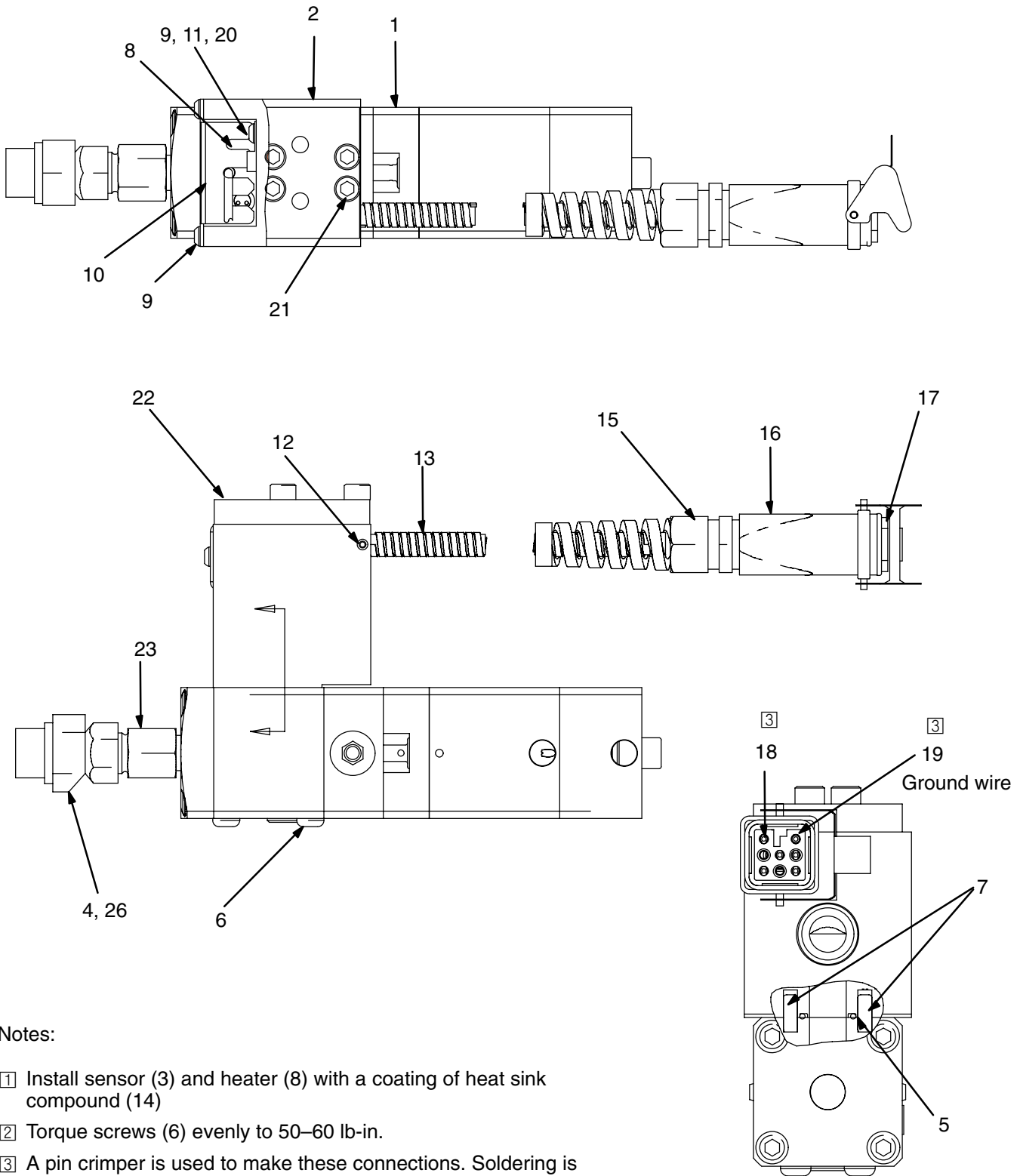

Notes:

- ① Install sensor (3) and heater (8) with a coating of heat sink compound (14)
- ② Torque screws (6) evenly to 50–60 lb-in.
- ③ A pin crimper is used to make these connections. Soldering is acceptable for replacements if a new pin is used.

Parts

Model 297261 (240 V Model)

Ref No.	Part No.	Description	Qty.	Ref No.	Part No.	Description	Qty.
1	244907	VALVE, ext, dispense, 400 deg. F	1	11	101674	TERMINAL, ring, ground	1
2	198236	MANIFOLD, electrical	1	12	105672	SCREW, set, sch.	1
4	118072	HEAD, applicator, swirl	1	13	116675	CORD, flex,	1
5**	109576	PACKING, o-ring, fluroelastomer	1	14*	073019	LUBRICANT, thermal	1
6	116412	SCREW, cap, button head, M6 x 60	4	15	116673	BUSHING, strain relief	1
7	114618	PIN, dowel, dia. 3/16 x 1/2 lg	2	16	116637	CONNECTOR, cable coupler hood	1
8	116614	HEATER, cartridge, 240 V	1	17	115860	INSERT, male	1
9	114185	SCREW, cap, button head	3	18	116640	CONTACT, connector	4
10	198232	GUARD, manifold,	1	19	115862	CONNECTOR, male, crimp	1
				20	065345	WIRE, copper, electrical (16 AWG)	2 ft.
				21	513035	SCREW, cap, shcs	4
				22	197843	Block, mounting	1
				23	15H098	ADAPTER, swirl	1
				26	117950	NOZZLE, swirl, .030	1

* not shown

** Included in repair kits. Kits also include manifold o-rings for all models.

Repair Kits

Part No.	Description
15E012	Standard seals
15E011	High temperature seals

Parts

Models 244961, 244908, and 245184 (120 V. Models)

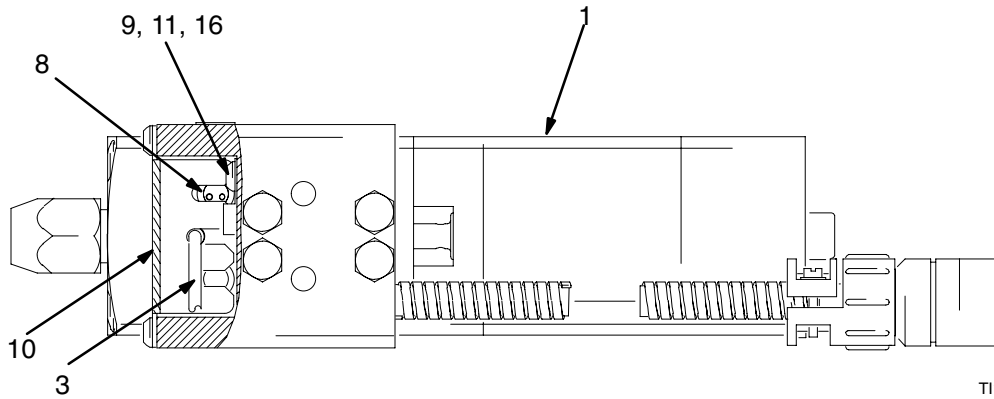

TI1384A

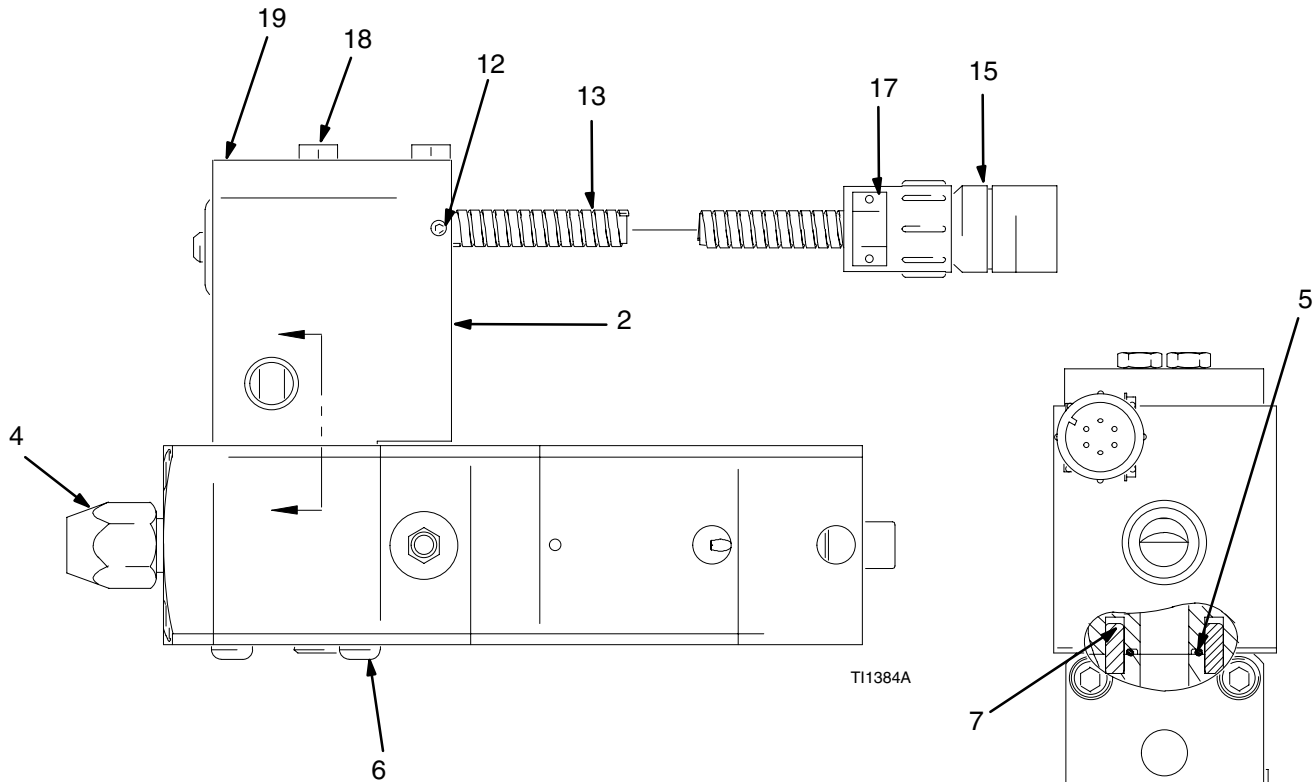

TI1384A

TI1384A

Notes:

- 1 Install sensor (3) and heater (8) with a coating of heat sink compound (14)
- 2 Torque screws (6) evenly to 50–60 in/lbs.

Parts

Models 244961, 244908, and 245184 (120 V. Models)

Ref No.	Part No.	Description	Qty.	Ref No.	Part No.	Description	Qty.
1	244535	VALVE, ext, dispense, 200 deg. F (model 244961)	1	8	116613	HEATER, cartridge, 120 V	1
1	244907	VALVE, ext, dispense, 400 deg. F (model 244908)	1	9	114185	SCREW, cap, button head	3
1	244937	VALVE, ext, dispense, 1/2 npt (model 245184)	1	10	198232	GUARD, manifold,	1
2	198236	MANIFOLD, electrical	1	11	101674	TERMINAL, ring, ground	1
3	C32255	SENSOR, temperature	1	12	105672	SCREW, set, sch.	1
4	C32089	RETAINER, nozzle	1	13	116675	CORD, flex,	1
5**	109576	PACKING, o-ring, fluoroelastomer	1	14*	073019	LUBRICANT, thermal	1
6	116412	SCREW, cap, button head, M6 x 60	4	15	116639	CONNECTOR, receptacle, male	1
7	114618	PIN, dowel, dia. 3/16 x 1/2 lg	2	16	065345	WIRE, copper, electrical (16 AWG)	2 ft.
				17	116688	CLAMP, cable	1
				18	513035	SCREW, cap, shcs	4
				19	197843	Block, mounting	1

* not shown

** Included in repair kits. Kits also include manifold o-rings for all models.

Repair Kits

Part No.	Description
15E012	Standard seals
15E011	High temperature seals

Parts

Model 244910 (ambient or temperature conditioned)

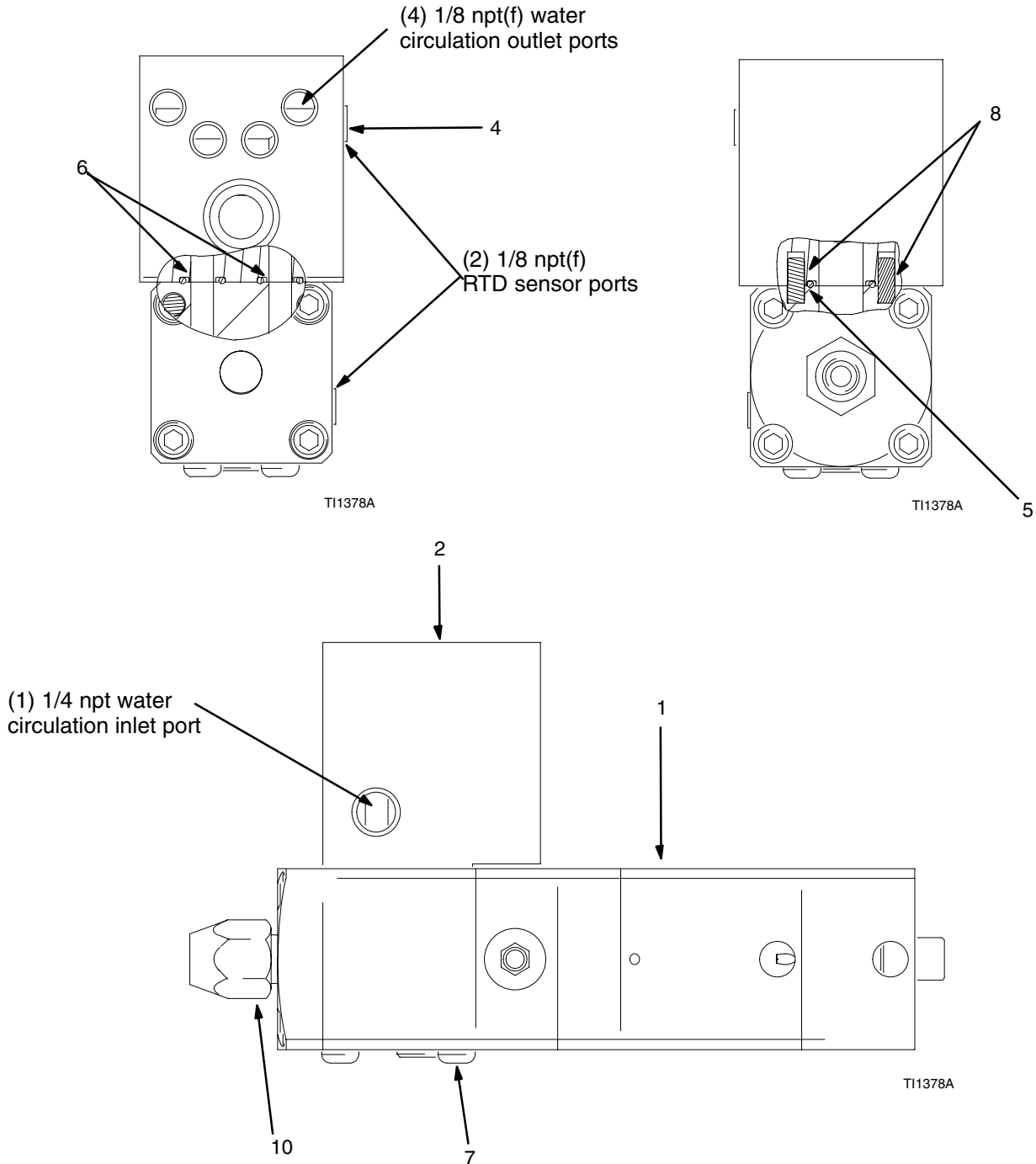

Notes:

- 1 Apply pipe sealant to threads per G standard 4.0520
- 2 Torque screws (7) evenly to 50–60 lb-in.
- 3 Mounting screws (9) loose with valve

Parts

Model 244910 (ambient or temperature conditioned)

Ref No.	Part No.	Description	Qty.	Ref No.	Part No.	Description	Qty.
1	244535	VALVE, ext, dispense, 200 deg. F	1	7	116412	SCREW, cap, button head	4
2	198235	MANIFOLD, water	1	8	114618	PIN, dowel dia 3/16 x 1/2 lg	2
3*	070408	SEALANT, pipe, sst	1	9	513035	SCREW, cap, shcs	4
4	110208	PLUG, pipe, headless	5	10	C32089	RETAINER, seat	1
5**	109576	PACKING, o-ring, fluroelastomer	1	*	not shown		
6**	106555	PACKING, o-ring	2	**	Included in repair kits. Kits also include manifold o-rings for all models.		

Repair Kits

Part No.	Description
15E012	Standard seals
15E011	High temperature seals

Accessories

Use Only Genuine Graco Parts and Accessories

Description **Part No.**

Tube Fittings for Air or Water

Suggested air fittings for automatic dispense valve air inlet ports. Do not use fittings with temperature ratings that are lower than the operating temperature of your system. Contact your Graco Service Representative for more information. These fittings are rated for at least 150 psi at 140° F.

	NPT	Tube	
90° elbow, push-in tube	1/8" male	1/4" O.D.	597151
90° elbow, push-in tube	1/8" male	5/32" (4mm)	198171
Straight push-in tube	1/8" male	1/4" O.D.	104172
Straight push-in tube	1/8" male	5/32" (4mm)	114263

For heated hoses reference 309160.

Solenoid Valve Kits for High Temperature Valves

For heated double acting air actuated valves. Includes solenoid, 24" high temperature air tubes, air fittings, and muffler.

Coil Voltage	
120 Volt AC	C58942
230 Volt AC	243703
24 Volt DC	C59038

Hose and Cable Kit

8 pin square female connector and 10 ft. of cable to mate with 240 VAC valves **244021**

Quick Exhaust Valve

1/8 npt(f) **104661**

Temperature Conditioning Accessories (Water Circulation)

RTD Sensor. 1/8 npt(m) x .81" (21mm) insertion length **198457**

3 pin Picofast connector fits the cable below

Sensor cable. 6 ft. (1.8 m) **198458**

3-pin Picofast 90° connector for RTD above (198457)

3-pin Omega connector on control end. Fits St. Clair temperature conditioning cable.

NOTE: The following accessories are not applicable to Model 297261.

Swirl Orbiter Adapters

Alternate nosepiece for valve outlet. 3/4-16 JIC(m). Fits inlet swivel on orbiter **197504**

45° orbiter mount uses the following parts:

45° Nosepiece **197842**

Alternate orbiter nut **198323**

Fitting nosepiece to orbiter **198324**

Streaming Adapter

Alternate outlet nut to retain 270xxx streaming tips or 182xxx fan tips (See Manual 308813) **617585**

Steel Dispense Nozzles

1/8 npt (m)

Length	Orifice Size	
2"	.125	607665
2"	.094	161505
2.12"	.055	164799
1.22"	.125	C17009
2.43"	.09 x.37 ribbon hardened tip	C01025

Repair Kits

Standard seals **15E012**

High temperature seals **15E011**

30 309376

Accessories

Description	Part No.
Cable Wrap 10" x 10" nylon fabric pad with Velcro strip. Used to secure the valve cable connector to the heated hose. Protects the electrical connectors in applications where the valve is being moved.	198422
Velcro Straps 1" x 12" strap used to secure ends of wrap 198422 above.	198442
Fluid Inlet Adapters	
1/2" NPT(m) x No. 8 JIC(m) (3/4 –16 with 37° flare)	C20700
1/2" NPT(m) x No. 10 JIC(m) (7/8 –14 with 37° flare)	C20703
1/2" NPT(m) x No. 12 JIC(m) (1-1/16 –12 with 37° flare)	C20642

Dimensions

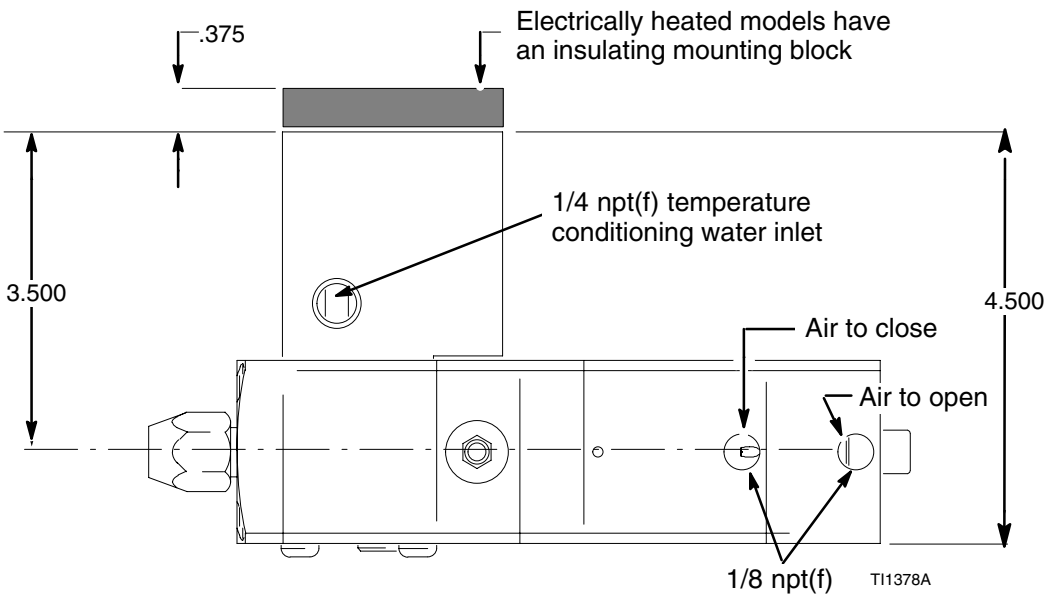
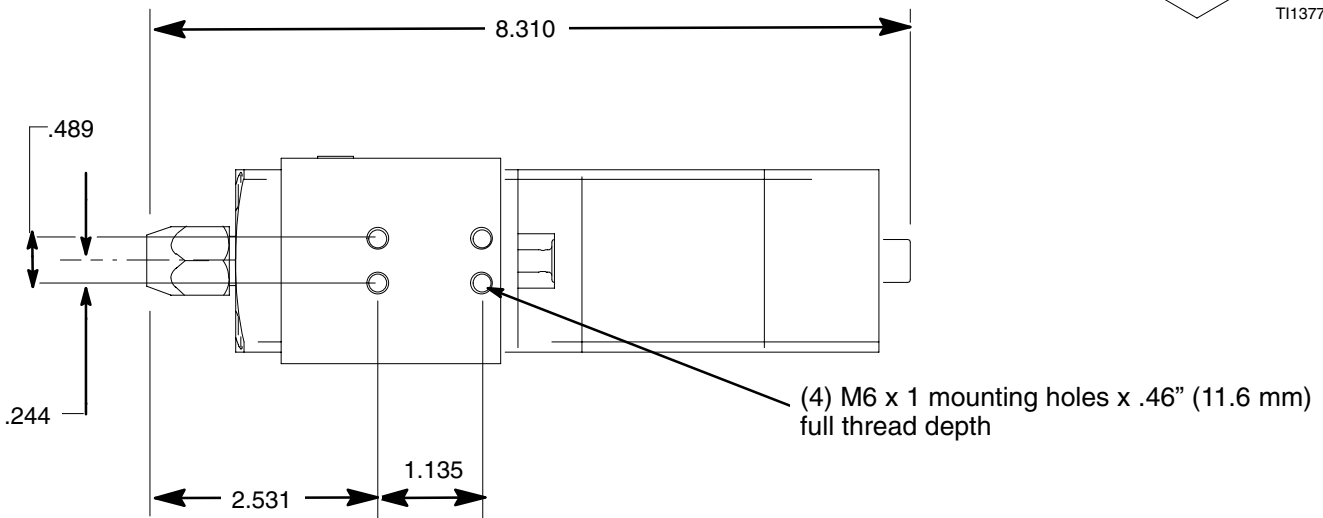
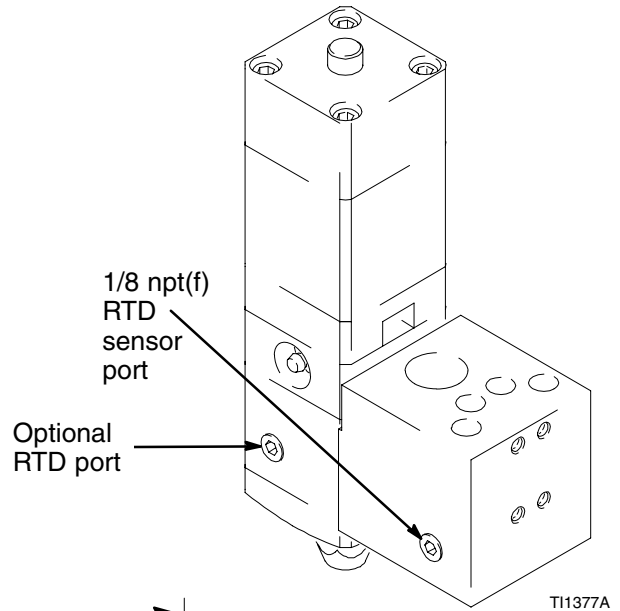
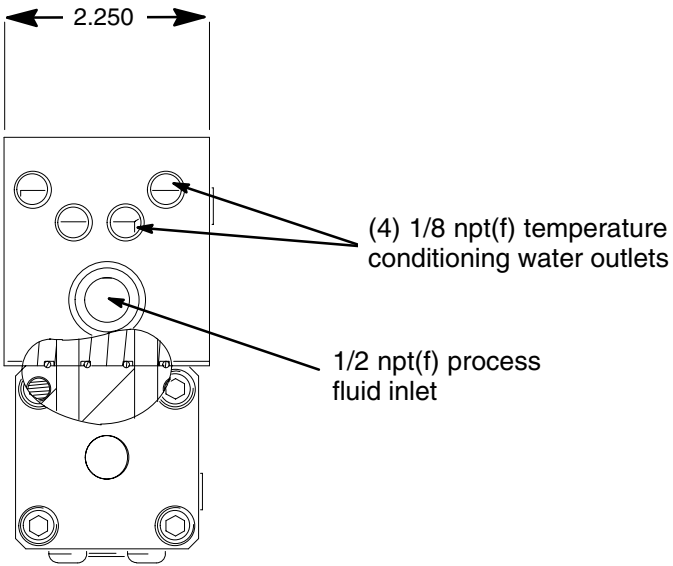

Dimensions

Model 297261 Only

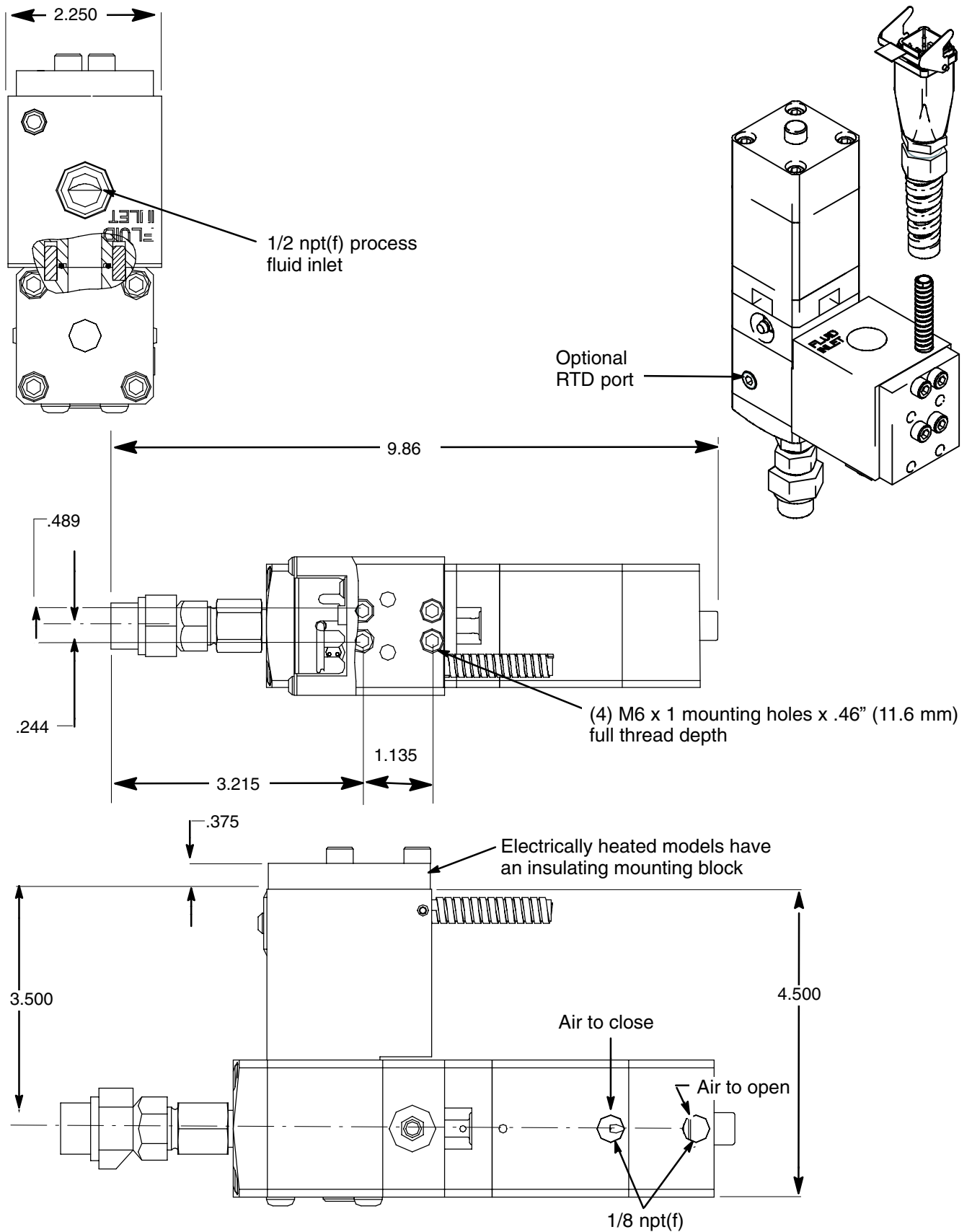

Technical Data

Maximum working fluid pressure	24.1 MPa (241 bar, 3500psi)
Maximum static fluid pressure	34.5 MPa (345 bar, 5000 psi)
Maximum working dry air pressure	.83 MPa (8.3 bar, 120 psi)
Maximum working temperature	
Standard seals in models 244535, 244910, 244961, 244962	95° C (200°)
High temperature seals in models 244907, 244908, 244909, 244937, 244951, 245184	204° C (400°)
Material Inlet on inlet manifold (all models)	1/2" npt(f)
Air Inlets (open and close)	1/8" npt
120 Volt Heater	150w @ 120 Vac, 96 ohms +/-10 pins C and F
240 Volt Heater	200w @ 240 VAC, 288 ohms +30/-40 pins 1 and 2
RTD Sensor (120 Volt models – pins A and B) (240 Volt models – pins 3 and 4)	100 Ohm platinum RTD, 0.00385 ohm/ohm/deg C (108.2 ohms @ 21° C (70° F))
Weight (automatic dispense valve + manifold)	approx. 1.8 kg (4 lbs)

Model 244910 can be temperature conditioned with circulating water. The valve/manifold is equipped with:

- (1) 1/4 npt(f) water inlet
- (4) 1/8 npt(f) water outlets
- (2) 1/8 npt(f) ports that can be used for a temperature sensor (see page 30).

WETTED PARTS (all valves)

Aluminum, Stainless Steel, chrome, carbide, acetal plastic, PTFE, fluoroelastomer

PRIMARY SEAL MATERIALS

Model 244535 – Polymyte® (orange) standard temperature

Models 244907 and 244937 – graphite fiber reinforced PTFE (black) high temperature

Material Outlet	
244951 and 245184	1/2 npt(m)
244910, 244961, 244962, 244908, 244909	5/8-18 with nut to accept 1/8 npt nozzles

Polymyte is a trademark of Parker Seal.

Wiring Diagram

120 Volt Models

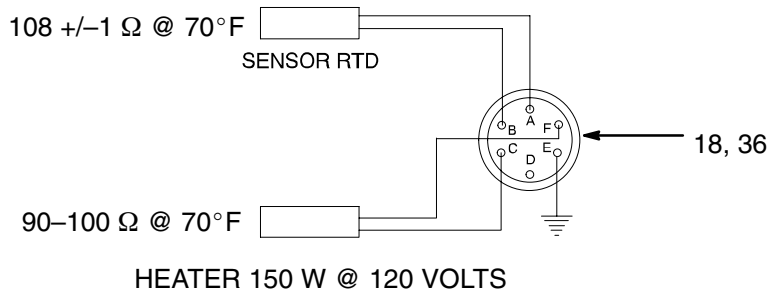

NOTE: ALLOW SUFFICIENT LEAD WIRE LENGTH TO BE ABLE TO ROTATE CONNECTOR BRACKET \pm 180°.

Past Therm-O-Flow™ accessories

240 Volt Models

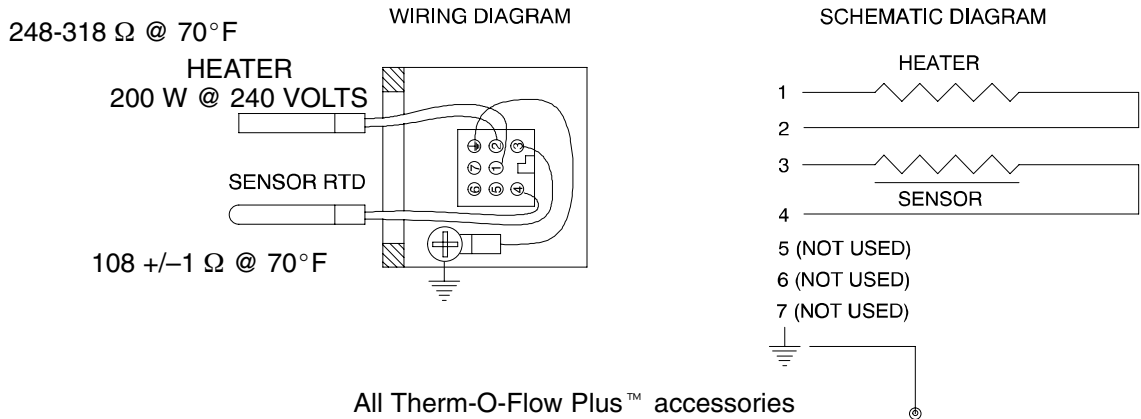

Graco Standard Warranty

Graco warrants all equipment referenced in this document which is manufactured by Graco and bearing its name to be free from defects in material and workmanship on the date of sale to the original purchaser for use. With the exception of any special, extended, or limited warranty published by Graco, Graco will, for a period of twelve months from the date of sale, repair or replace any part of the equipment determined by Graco to be defective. This warranty applies only when the equipment is installed, operated and maintained in accordance with Graco's written recommendations.

This warranty does not cover, and Graco shall not be liable for general wear and tear, or any malfunction, damage or wear caused by faulty installation, misapplication, abrasion, corrosion, inadequate or improper maintenance, negligence, accident, tampering, or substitution of non-Graco component parts. Nor shall Graco be liable for malfunction, damage or wear caused by the incompatibility of Graco equipment with structures, accessories, equipment or materials not supplied by Graco, or the improper design, manufacture, installation, operation or maintenance of structures, accessories, equipment or materials not supplied by Graco.

This warranty is conditioned upon the prepaid return of the equipment claimed to be defective to an authorized Graco distributor for verification of the claimed defect. If the claimed defect is verified, Graco will repair or replace free of charge any defective parts. The equipment will be returned to the original purchaser transportation prepaid. If inspection of the equipment does not disclose any defect in material or workmanship, repairs will be made at a reasonable charge, which charges may include the costs of parts, labor, and transportation.

THIS WARRANTY IS EXCLUSIVE, AND IS IN LIEU OF ANY OTHER WARRANTIES, EXPRESS OR IMPLIED, INCLUDING BUT NOT LIMITED TO WARRANTY OF MERCHANTABILITY OR WARRANTY OF FITNESS FOR A PARTICULAR PURPOSE.

Graco's sole obligation and buyer's sole remedy for any breach of warranty shall be as set forth above. The buyer agrees that no other remedy (including, but not limited to, incidental or consequential damages for lost profits, lost sales, injury to person or property, or any other incidental or consequential loss) shall be available. Any action for breach of warranty must be brought within two (2) years of the date of sale.

GRACO MAKES NO WARRANTY, AND DISCLAIMS ALL IMPLIED WARRANTIES OF MERCHANTABILITY AND FITNESS FOR A PARTICULAR PURPOSE, IN CONNECTION WITH ACCESSORIES, EQUIPMENT, MATERIALS OR COMPONENTS SOLD BUT NOT MANUFACTURED BY GRACO. These items sold, but not manufactured by Graco (such as electric motors, switches, hose, etc.), are subject to the warranty, if any, of their manufacturer. Graco will provide purchaser with reasonable assistance in making any claim for breach of these warranties.

In no event will Graco be liable for indirect, incidental, special or consequential damages resulting from Graco supplying equipment hereunder, or the furnishing, performance, or use of any products or other goods sold hereto, whether due to a breach of contract, breach of warranty, the negligence of Graco, or otherwise.

FOR GRACO CANADA CUSTOMERS

The parties acknowledge that they have required that the present document, as well as all documents, notices and legal proceedings entered into, given or instituted pursuant hereto or relating directly or indirectly hereto, be drawn up in English. Les parties reconnaissent avoir convenu que la rédaction du présente document sera en Anglais, ainsi que tous documents, avis et procédures judiciaires exécutés, donnés ou intentés à la suite de ou en rapport, directement ou indirectement, avec les procédures concernées.

Graco Information

For the latest information about Graco products, visit www.graco.com.

TO PLACE AN ORDER, contact your Graco distributor, or call one of the following numbers to identify the distributor closest to you:

1-800-328-0211 Toll Free
612-623-6921
612-378-3505 Fax

All written and visual data contained in this document reflects the latest product information available at the time of publication. Graco reserves the right to make changes at any time without notice.

Original instructions. This manual contains English. MM 309376

Graco Headquarters: Minneapolis
International Offices: Belgium, China, Japan, Korea

GRACO INC. AND SUBSIDIARIES • P.O. BOX 1441 • MINNEAPOLIS MN 55440-1441 • USA
Copyright 2004, Graco Inc. All Graco manufacturing locations are registered to ISO 9001.

www.graco.com
Revised 01/2012