

# Dispensit 1053-10C

3A0874D

EN

***Patented meter and dispense system for precise one-component micro-dispensing. Not for use in explosive atmospheres.***

*2000 psi (14 MPa, 138 bar) Maximum Outlet Fluid Working Pressure*

*100 psi (0.7 MPa, 7 bar) Maximum Air Working Pressure*

*110°F (43°C) Maximum Ambient Temperature*

*300°F (149°C) Maximum Operating Temperature*



### **Important Safety Instructions**

Read all warnings and instructions in this manual. Save these instructions.

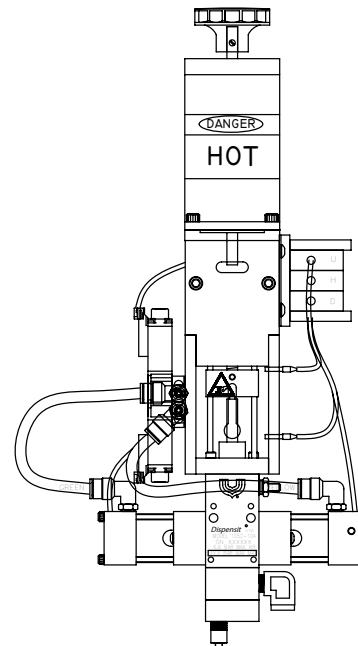

*Valve shown is with controls/motor integrated*

# Contents

- Related Manuals** ..... 2
- Warnings** ..... 3
- Isocyanate Conditions** ..... 5
- Material Self-ignition** ..... 5
- Moisture Sensitivity of Isocyanates** ..... 5
- Changing Materials** ..... 5
- Grounding** ..... 6
- Overview** ..... 6
- Cycle Detection Spool Sensors** ..... 6
- Component Identification** ..... 7
  - Typical System Configurations ..... 7
  - Typical Feed System Components ..... 8
  - Typical Feed System Components (continued) . . 9
  - Metering Valve ..... 10
- Setup** ..... 11
  - Typical Installation ..... 11
  - Valve Mounting Diagram ..... 12
  - Motor Mounting Diagram ..... 13
- Startup** ..... 14
- Operation** ..... 15
  - Sequence of Operation ..... 15
- Pressure Relief Procedure** ..... 16
- Shutdown** ..... 16
- Maintenance** ..... 16
- Troubleshooting** ..... 17
- Schematics** ..... 17
- Rebuild** ..... 18
  - Disassembly ..... 18
  - Model 1053-10C General Illustration ..... 19
  - Assembly ..... 20
  - Motor and Motor Coupling Assembly ..... 22
- Motor and Motor Coupling Illustration** ..... 23
- Electrical Requirements** ..... 24
- Technical Data** ..... 25
  - Motor Specifications ..... 25
- Graco Standard Warranty** ..... 26
- Graco Information** ..... 26





# Related Manuals

Component manuals in U.S. English.



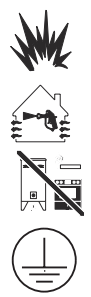

Part	Description
3A0261	1053/1093 Control Box

# Warnings





The following warnings are for the setup, use, grounding, maintenance, and repair of this equipment. The exclamation point symbol alerts you to a general warning and the hazard symbol refers to procedure-specific risk. Refer back to these warnings. Additional, product-specific warnings may be found throughout the body of this manual where applicable.

 <b>WARNING</b>	
	<p><b>SKIN INJECTION HAZARD</b></p> <p>High-pressure fluid from gun, hose leaks, or ruptured components will pierce skin. This may look like just a cut, but it is a serious injury that can result in amputation. <b>Get immediate surgical treatment.</b></p> <ul style="list-style-type: none"> <li>• Do not point gun at anyone or at any part of the body.</li> <li>• Do not put your hand over the dispense outlet.</li> <li>• Do not stop or deflect leaks with your hand, body, glove, or rag.</li> <li>• Follow <b>Pressure Relief Procedure</b> in this manual, when you stop dispensing and before cleaning, checking, or servicing equipment.</li> </ul>
	<p><b>TOXIC FLUID OR FUMES HAZARD</b></p> <p>Toxic fluids or fumes can cause serious injury or death if splashed in the eyes or on skin, inhaled, or swallowed.</p> <ul style="list-style-type: none"> <li>• Read MSDS's to know the specific hazards of the fluids you are using.</li> <li>• Store hazardous fluid in approved containers, and dispose of it according to applicable guidelines.</li> <li>• Always wear impervious gloves when spraying or cleaning equipment.</li> <li>• If this equipment is used with isocyanate material, see additional information on isocyanates in Iso-cyanate Conditions Section of this manual.</li> </ul>
	<p><b>PERSONAL PROTECTIVE EQUIPMENT</b></p> <p>You must wear appropriate protective equipment when operating, servicing, or when in the operating area of the equipment to help protect you from serious injury, including eye injury, inhalation of toxic fumes, burns, and hearing loss. This equipment includes but is not limited to:</p> <ul style="list-style-type: none"> <li>• Protective eyewear</li> <li>• Clothing and respirator as recommended by the fluid and solvent manufacturer</li> <li>• Gloves</li> <li>• Hearing protection</li> </ul>
	<p><b>FIRE AND EXPLOSION HAZARD</b></p> <p>Flammable fumes, such as solvent and paint fumes, in <b>work area</b> can ignite or explode. To help prevent fire and explosion:</p> <ul style="list-style-type: none"> <li>• Use equipment only in well ventilated area.</li> <li>• Eliminate all ignition sources; such as pilot lights, cigarettes, portable electric lamps, and plastic drop cloths (potential static arc).</li> <li>• Keep work area free of debris, including solvent, rags and gasoline.</li> <li>• Do not plug or unplug power cords, or turn power or light switches on or off when flammable fumes are present.</li> <li>• Ground all equipment in the work area. See <b>Grounding</b> instructions.</li> <li>• Use only grounded hoses.</li> <li>• If there is static sparking or you feel a shock, <b>stop operation immediately</b>. Do not use equipment until you identify and correct the problem.</li> <li>• Keep a working fire extinguisher in the work area.</li> </ul>

**WARNING**

	<p><b>ELECTRIC SHOCK HAZARD</b></p> <p>This equipment must be grounded. Improper grounding, setup, or usage of the system can cause electric shock.</p> <ul style="list-style-type: none"> <li>• Turn off and disconnect power cord before servicing equipment.</li> <li>• Use only grounded electrical outlets.</li> <li>• Use only 3-wire extension cords.</li> <li>• Ensure ground prongs are intact on power and extension cords.</li> <li>• Do not expose to rain. Store indoors.</li> </ul>
	<p><b>EQUIPMENT MISUSE HAZARD</b></p> <p>Misuse can cause death or serious injury.</p> <ul style="list-style-type: none"> <li>• Do not operate the unit when fatigued or under the influence of drugs or alcohol.</li> <li>• Do not exceed the maximum working pressure or temperature rating of the lowest rated system component. See <b>Technical Data</b> in all equipment manuals.</li> <li>• Do not leave the work area while equipment is energized or under pressure. Turn off all equipment and follow the <b>Pressure Relief Procedure</b> in this manual when equipment is not in use.</li> <li>• Check equipment daily. Repair or replace worn or damaged parts immediately with genuine manufacturer's replacement parts only.</li> <li>• Do not alter or modify equipment.</li> <li>• Use equipment only for its intended purpose. Call your distributor for information.</li> <li>• Route hoses and cables away from traffic areas, sharp edges, moving parts, and hot surfaces.</li> <li>• Do not kink or over bend hoses or use hoses to pull equipment.</li> <li>• Keep children and animals away from work area.</li> <li>• Comply with all applicable safety regulations.</li> </ul>
	<p><b>MOVING PARTS HAZARD</b></p> <p>Moving parts can pinch or amputate fingers and other body parts.</p> <ul style="list-style-type: none"> <li>• Keep clear of moving parts.</li> <li>• Do not operate equipment with protective guards or covers removed.</li> <li>• Pressurized equipment can start without warning. Before checking, moving, or servicing equipment, follow the <b>Pressure Relief Procedure</b> in this manual. Disconnect power or air supply.</li> </ul>
	<p><b>PLASTIC PARTS CLEANING SOLVENT HAZARD</b></p> <p>Use only compatible water-based solvents to clean plastic structural or pressure-containing parts. Many solvents can degrade plastic parts and cause them to fail, which could cause serious injury or property damage. See <b>Technical Data</b> in this and all other equipment instruction manuals. Read fluid and solvent manufacturer's warnings.</p>
	<p><b>BURN HAZARD</b></p> <p>Equipment surfaces and fluid that's heated can become very hot during operation. To avoid severe burns, do not touch hot fluid or equipment. Wait until equipment/fluid has cooled completely.</p>

# Isocyanate Conditions



						
<p>Spraying or dispensing materials containing isocyanates creates potentially harmful mists, vapors, and atomized particulates.</p> <p>Read material manufacturer's warnings and material MSDS to know specific hazards and precautions related to isocyanates.</p> <p>Prevent inhalation of isocyanate mists, vapors, and atomized particulates by providing sufficient ventilation in the work area. If sufficient ventilation is not available, a supplied-air respirator is required for everyone in the work area.</p> <p>To prevent contact with isocyanates, appropriate personal protective equipment, including chemically impermeable gloves, boots, aprons, and goggles, is also required for everyone in the work area.</p>						

- Keep the ISO lube pump reservoir (if installed) filled with Graco Throat Seal Liquid (TSL), Part 206995. The lubricant creates a barrier between the ISO and the atmosphere.
- Use moisture-proof hoses specifically designed for ISO, such as those supplied with your system.
- Never use reclaimed solvents, which may contain moisture. Always keep solvent containers closed when not in use.
- Always lubricate threaded parts with ISO pump oil or grease when reassembling.

## Changing Materials

- When changing materials, flush the equipment multiple times to ensure it is thoroughly clean.
- Always clean the fluid inlet strainers after flushing.
- Check with your material manufacturer for chemical compatibility.

## Material Self-ignition

						
<p>Some materials may become self-igniting if applied too thickly. Read material manufacturer's warnings and material MSDS.</p>						

## Moisture Sensitivity of Isocyanates

ISO will react with moisture (such as humidity) to form small, hard, abrasive crystals, which become suspended in the fluid. Eventually a film will form on the surface and the ISO will begin to gel, increasing in viscosity. If used, this partially cured ISO will reduce performance and the life of all wetted parts.

**NOTE:** The amount of film formation and rate of crystallization varies depending on the blend of ISO, the humidity, and the temperature.

To prevent exposing ISO to moisture:

- Always use a sealed container with a desiccant dryer in the vent, or a nitrogen atmosphere. **Never** store ISO in an open container.

## Grounding

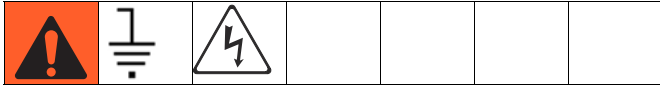

This product must be grounded. In the event of an electrical short circuit, grounding reduces the risk of electric shock by providing an escape wire for the electric current.

**Metering valve:** attach ground wire from grounding lug to true earth ground. See **Component Identification** starting on page 7.

**Fluid hoses:** use only electrically conductive hoses.

**Feed system components:** attach ground wire from grounding lug to true earth ground. See feed system manual for grounding points.

**Fluid supply container:** follow local code.

**Solvent pails used when flushing:** follow local code. Use only conductive metal pails, placed on a grounded surface. Do not place the pail on a nonconductive surface, such as paper or cardboard, which interrupts grounding continuity.

## Overview

This single-component meter and dispense device accurately meters liquid and semi-paste materials.

The machine is designed for application that require very small and precisely dispensed beads and/or dots of material at a wide range of material inlet pressures.

The ratio of the flow rate/stroke length to pump shaft area provides the adjustable pressure intensification needed to move the separate liquids through the needle with a flow rate suitable for production requirements.

The complete system is enclosed. See **Sequence of Operation** on page 15.

## Cycle Detection Spool Sensors

The spool sensors are magnetic reed switches and must be connected to an electrical control. An LED on the switch illuminates to indicate the shifting of the spool.

# Component Identification

## Typical System Configurations

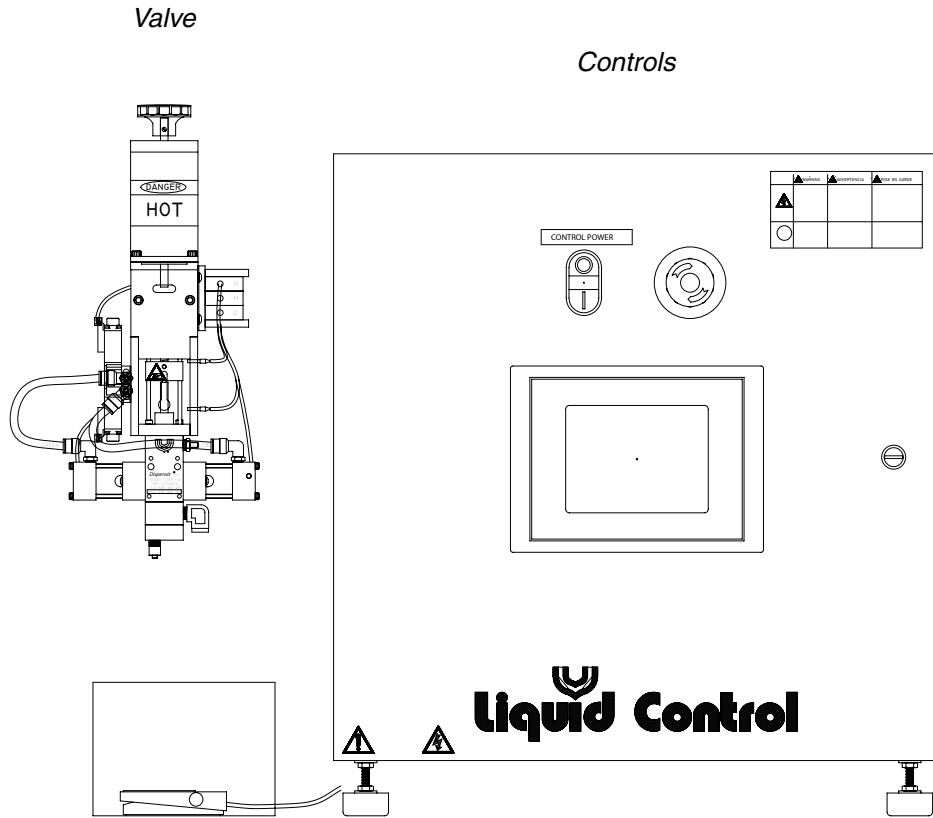

*System shown with optional controls*

**FIG. 1**

# Typical Feed System Components

20 oz Cartridge Feed  
with Mounting Post

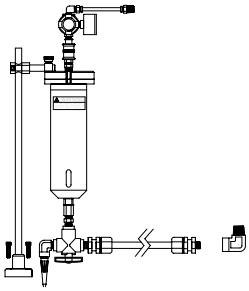

1 Gallon Ram  
and Pump

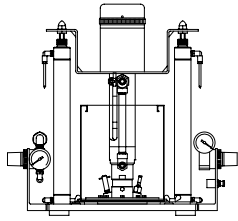

5 Gallon Pail Cover  
with Diaphragm Pump

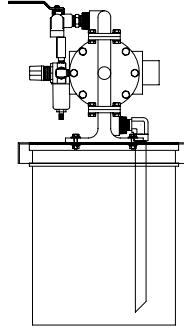

5 Gallon Pail Cover  
with Diaphragm  
Pump and Agitator

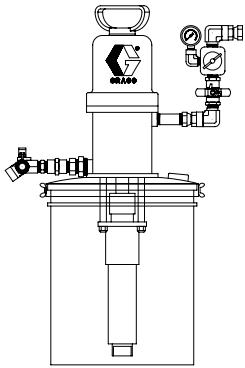
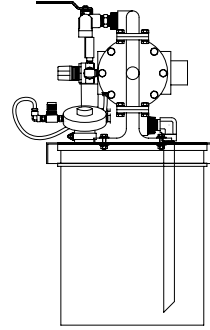

5 Gallon Pail Cover  
with 5:1 Transfer  
Pump

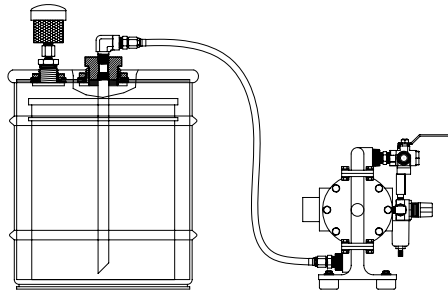

5 Gallon Pail Cover  
with Diaphragm  
Pump

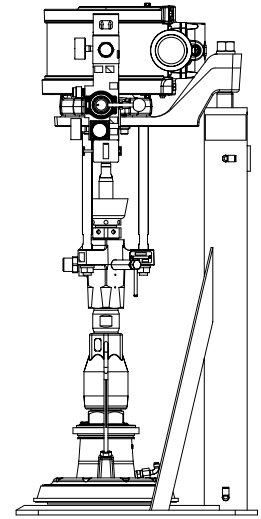

5 Gallon Ram and  
11:1 Transfer Pump

FIG. 2



## Typical Feed System Components (continued)

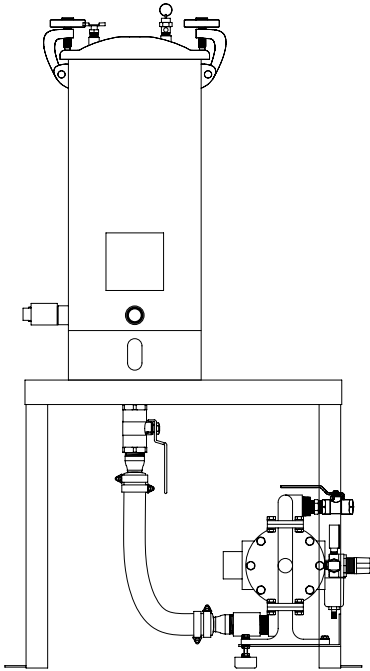

5 Gallon Tank with Diaphragm Pump and Stand

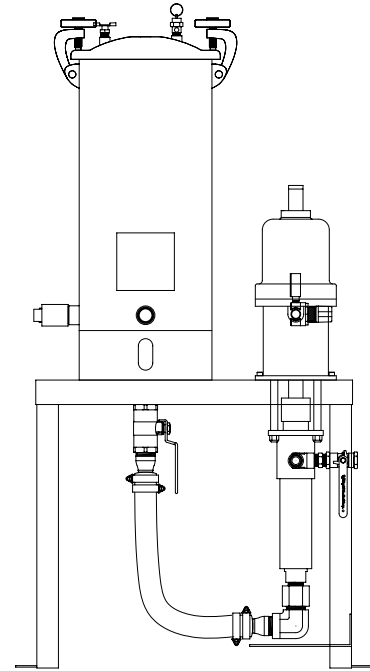

5 Gallon Tank with 5:1 Pump and Stand

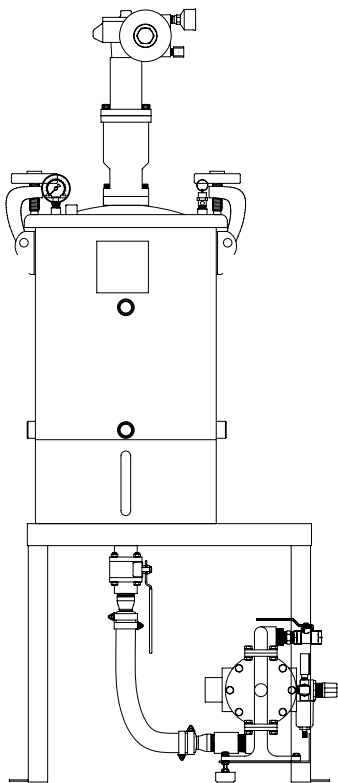

10 Gallon Tank with Diaphragm Pump, Agitator, Vacuum, and Stand

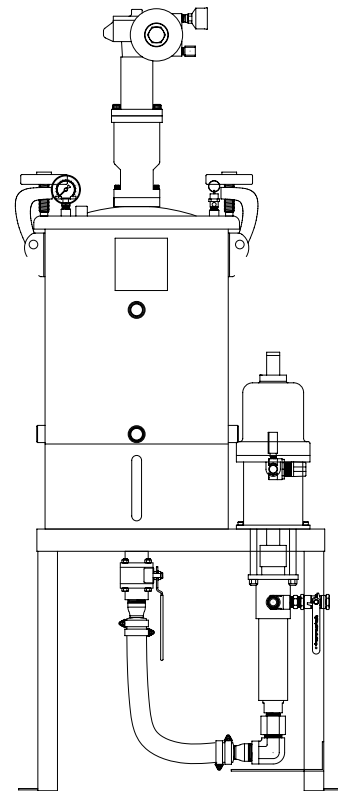

10 Gallon Tank with 5:1 Pump, Agitator, Vacuum, and Stand

FIG. 3

# Metering Valve

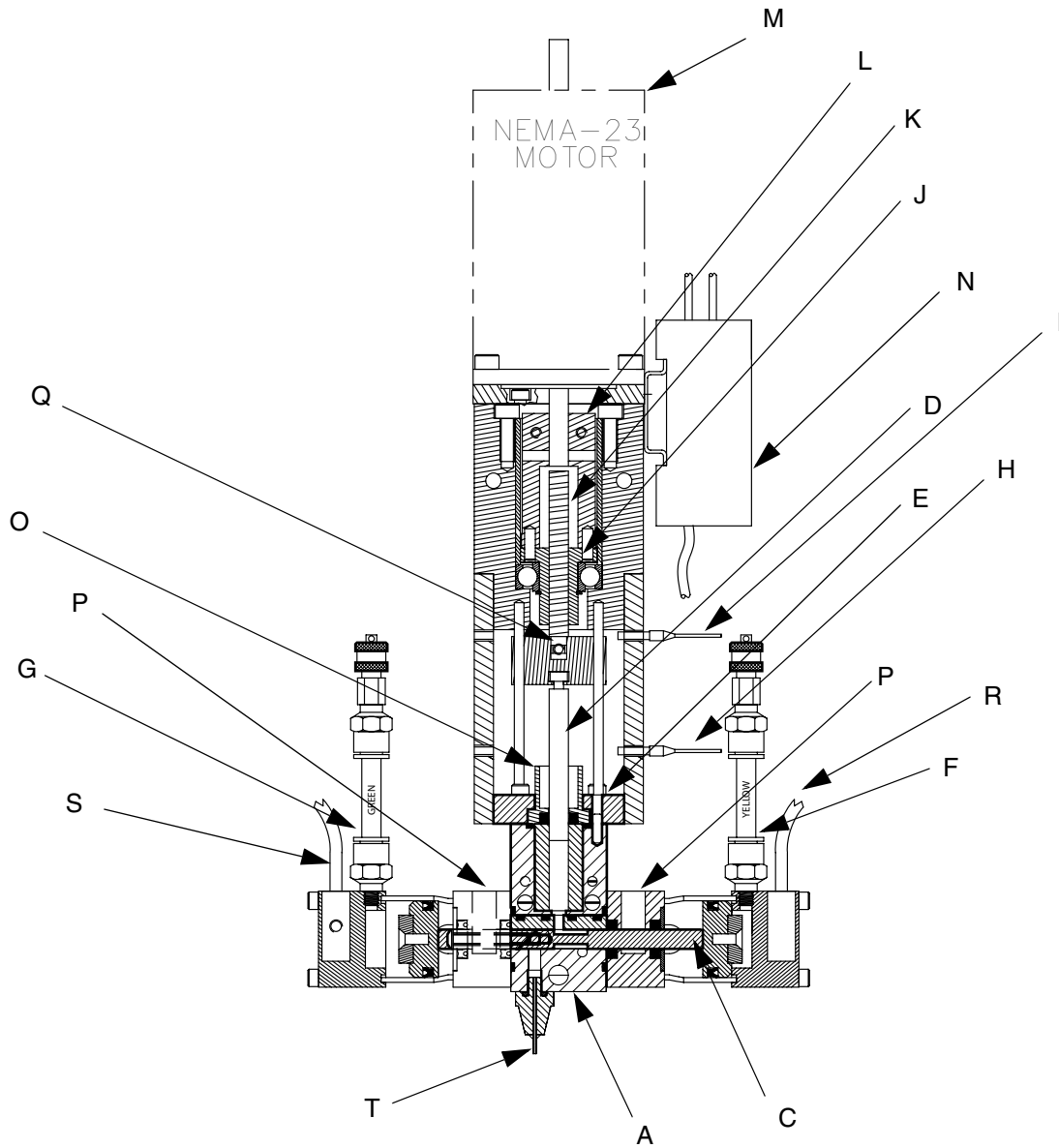

**Key:**

- |   |                         |   |                    |   |                     |   |                     |
|---|-------------------------|---|--------------------|---|---------------------|---|---------------------|
| A | Material Inlet          | F | Dispense Air Inlet | L | Drive Coupling      | R | Spool Sensor Close  |
| B | Grounding Lug           | G | Reload Air Inlet   | M | Motor               | S | Spool Sensor Open   |
| C | Spool                   | H | Lower Sensor       | N | Sensor Amplifiers   | T | Needle with Adapter |
| D | Metering Rod            | I | Upper Sensor       | O | Oil Cup             |   |                     |
| E | Oil Cup Retaining Block | J | Drive Nut          | P | Wet Cups            |   |                     |
|   |                         | K | Drive Screw        | Q | Drive Locking Screw |   |                     |

FIG. 4

# Setup

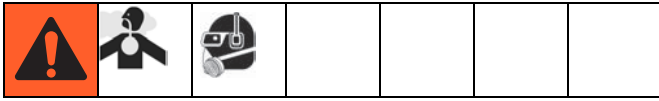

**NOTE:** See **Typical Installation** diagram.

1. Perform Setup procedure for feed system components. See feed system manual(s).
2. Place an in-line air pressure regulator, air-water separator/filter, and shut-off/bleed valve between the air supply and the control solenoids.
3. Connect each 1/4 in. outside diameter supplied air line to the corresponding control solenoid. See **Component Identification** starting on page 7.
4. Connect chemical lines from feed system to metering valve material inlets. See **Component Identification** starting on page 7.

## Typical Installation

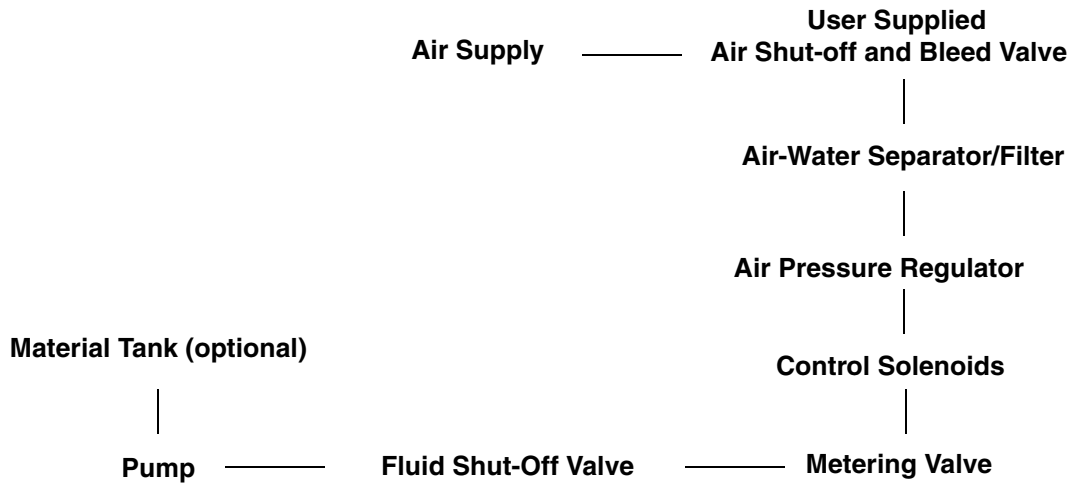

FIG. 5

## Valve Mounting Diagram

As desired, use the following diagram to mount the metering valve.

**NOTE: Valve shown is for controls/motor integrated. For valve without controls/motor integrated, mounting pattern is the same just less LS-Home, solenoid open/close and all the wires terminated at a plug.**

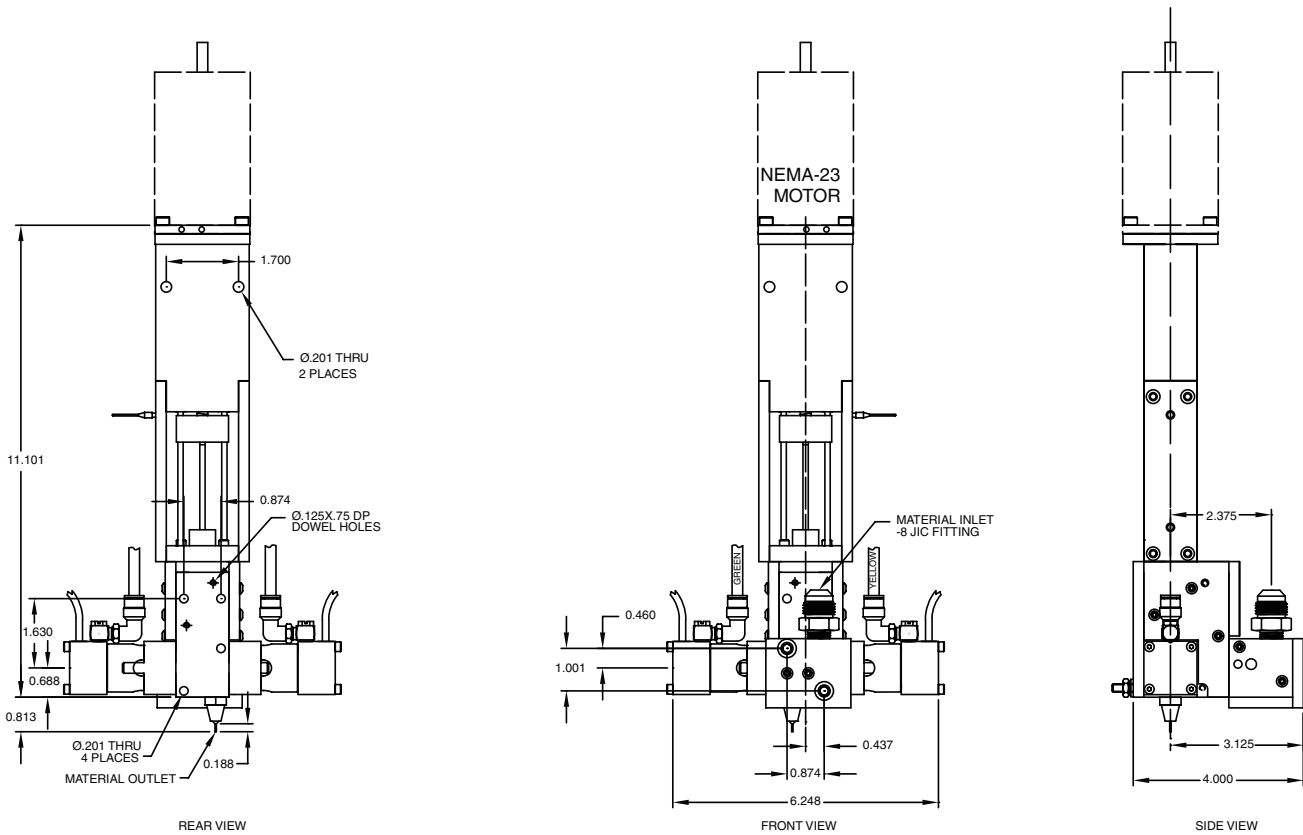
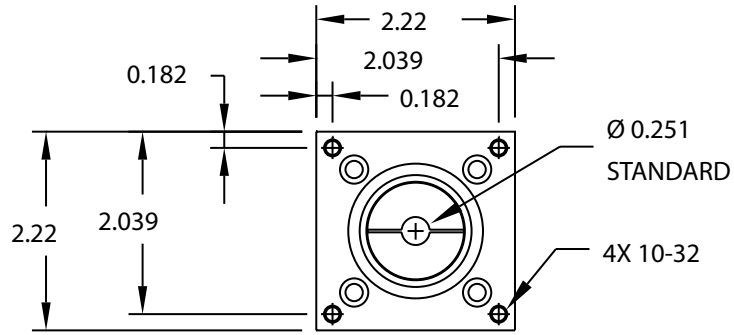

FIG. 6

# Motor Mounting Diagram

If using a non-Graco motor with the dispense valve, use the following diagram to install the non-Graco motor onto the valve. See **Motor Specifications** on page 25.



# Startup



1. Lubricate the metering rod port in the oil cup retaining block and fill the spool valve ports with compatible lubricant such as mesamoll or silicone oil.

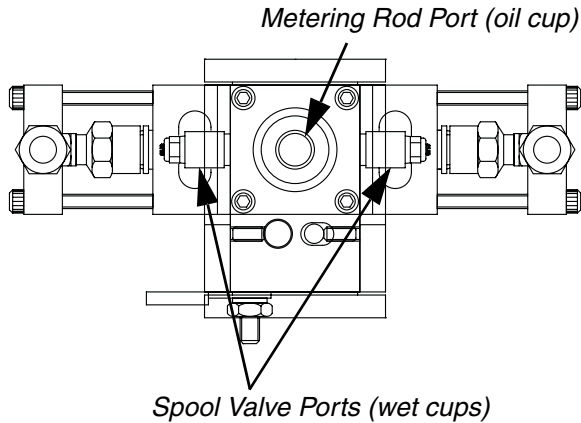

**FIG. 7: Top View of Metering Valve with Top Section Removed**

2. Pressurize the feed systems connected to the metering valve to prime the system. See **Technical Data** on page 25 for maximum inlet feed pressure.
3. Dispense several full stroke shots until material is air-free and has good shut-off at the nose.

**NOTE:** Very viscous, compressible materials may continue to droll after system is primed. Reduce flow rate as required to produce air-free dispense.

**NOTE:** Very thin materials may require tilting the valve greater than 45 degrees and dispensing shots until material is air-free. Remove oil from cups before proceeding.

# Operation

The operation of the 1053 metering valve is controlled by an external source. If a Control Box was purchased, see the Control Box manual for operation instructions. See **Related Manuals** on page 2.

## Sequence of Operation

### Step 1: Reload

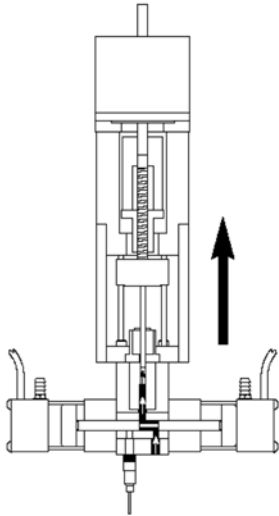

- Spool shifts to the right
- Material feed inlet is opened
- Material is transferred into the metering chambers by a pressurized feed system
- Outlet port is blocked
- Metering rod is retracted to a precise position determining the volume of each material

### Step 2: Shift

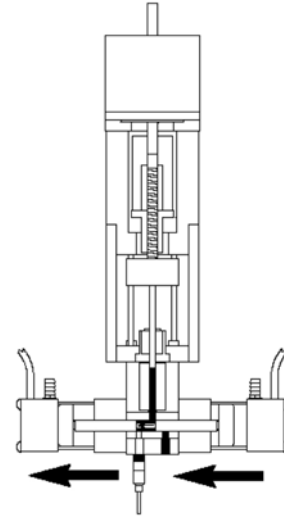

- The balanced spool shifts to the dispense position
- Material path to the needle is opened
- Material feed inlet port is blocked
- Metering rod remains in the retracted position

### Step 3: Dispense

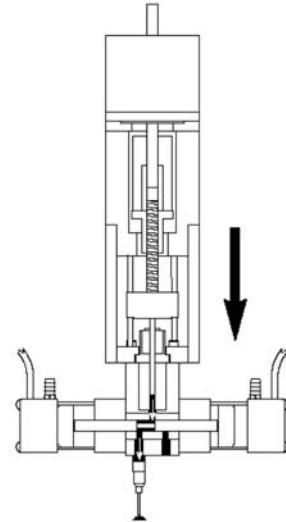

- Metering rod extends
- Material is dispensed from the metering chamber into the needle

Upon completion of the dispense stroke, the metering rod and spool shifts back to the reload position.

# Pressure Relief Procedure

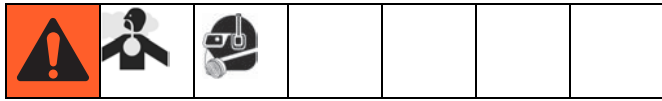

1. Retract the metering rods. See the Control Box manual. See **Related Manuals** on page 2.
2. Close the fluid shut-off valve.
3. Remove needle.
4. Dispense 5 shots. Shots should be at least 75% of the full stroke.
5. Extend the metering rod into the tubes. If Graco controls are provided with the system, see the Controls manual. See **Related Manuals** on page 2.
6. Close the incoming air shut-off/bleed valve that supplies air to the metering valve.
7. Close the incoming air shut-off/bleed valve that supplies the feed system. Refer to feed system manual for pressure relief procedure.

# Shutdown



1. Perform **Pressure Relief Procedure**.
2. Inspect the metering rod for material buildup. Clean as necessary.
3. Lubricate the metering rod with compatible lubricant such as mesamoll or silicone oil.
4. Remove needle adapter and replace with 10-32 set screw.

# Maintenance



Perform the following procedures once a shift.

**NOTE:** If material is leaking, see **Troubleshooting** on page 17.

## Material Reservoirs

Check material levels and refill as necessary. Ensure that the material reservoirs are properly vented.

## Air Dryer

Check the condition of the desiccant air dryer. Replace as necessary.

## Metering Rod Port (oil cup)



Lubricate with compatible lubricant such as mesamoll or silicone oil. See FIG. 7 on page 14.

## Spool Valve Port (wet cups)

Fill with compatible lubricant such as mesamoll or silicone oil. See FIG. 7 on page 14.



# Troubleshooting

						
Perform <b>Pressure Relief Procedure</b> before performing any troubleshooting procedure.						

Problem	Cause	Solution
Metering valve stalling and no material being dispensed despite adequate input pressure	Blocked needle	Check needle for cured material, replace as required
Metering valve not discharging normal or full volume	Low material level in reservoirs	Fill material reservoirs and prime the machine
	Air in material tank	Fill reservoir and prime machine
Material leaks past spool valve	Spool valve worn or damaged	Replace the spool valve
The 1053 valve will not cycle	Cycle detection sensors not working	Check connections or replace as needed
The 1053 valve cycles slowly	Oil cup/wet cups are not supplied with lubrication	Add lubrication. Note: Lubrication must be compatible with all seals.
The 1053 valve drools or leaks	Air is trapped in the valve	Prime the valve until air/free material is visible
	Seals are worn	Replace seals
Spool will not actuate	Low air pressure	Increase air pressure to approximately 20-30 psi
	Cured material on spool	Check spool for cured material, replace as required
	Seals are worn	Replace seals

## Schematics

**For standard machines**, the schematics will be included in the Controls Parts manual. See **Related Manuals** on page 2.

**For custom machines**, the schematics will be included in the assembly drawings manual.

# Rebuild

Before proceeding, remove material feed line and pump material out of the valve. Shut power off from control panel and disconnect main power. Disconnect the motor wire harness from the system. Loosen the home and spool sensor set screws. Note the position of the sensors and slide them out of the valve. Disconnect the air lines.

## Disassembly

Refer to the illustration below and the drawings in the back of this manual for your exact model.

### Disassembly Of 1053 Valve Section

1. Remove motor from Mounting Plate (23).
2. Remove mounting screws to remove valve from its support.
3. On the right side of the valve, remove Valve End Cap (25). The Valve Piston (24) will be inside the end cap.  
**Note: If necessary, remove Valve Piston (24) from Valve End Cap (25) by applying low air pressure through valve to push out the Valve Piston (24).**
4. Remove Seal Plate (14).
5. Repeat steps 3 and 4 with the left side of the valve.
6. Push the Spool (7) and (36) out with a finger. If it does not slide out, tap it gently using a wood or plastic dowel. *A worn spool and sleeve assembly must be replaced with a new (matched) assembly. If you are rebuilding multiple valves be sure to keep the spools and sleeves matched.*
7. Remove Side Blocks (17) from Bottom Block (11) and Divorced Section (6).
8. Remove Valve Body (3) from Bottom Block (11) by removing Screws (31).
9. Remove Dispense Sleeve(27) from Valve Body (3).
10. Slide Bottom Block (11) away from Metering Rod (1) and Guide Rods (32).
11. Remove Seal Cup (2) from Bottom Block (11). Remove Posipak Seal (30) from Seal Cup (2).
12. Slide Guide Rods (32) out of Connection Block (18).
13. Remove Metering Rod (1) from Connection Block (18).

**NOTE: Only perform the steps below if the Motor Coupling Section needs rebuilt.**

### Disassembly Of Motor Coupling Section

14. Loosen Screws (4) to disconnect Connection Block (18) from Lead Screw (20).
15. Remove Mounting Plate (23) from Divorced Section (6).
16. Remove Screws (33) from Divorced Section (6).
17. Remove Retaining Sleeve (21) from Divorced Section (6).
18. Remove Lead Screw (20) and Lead Screw Nut (19) from Divorced Section (6).

# Model 1053-10C General Illustration

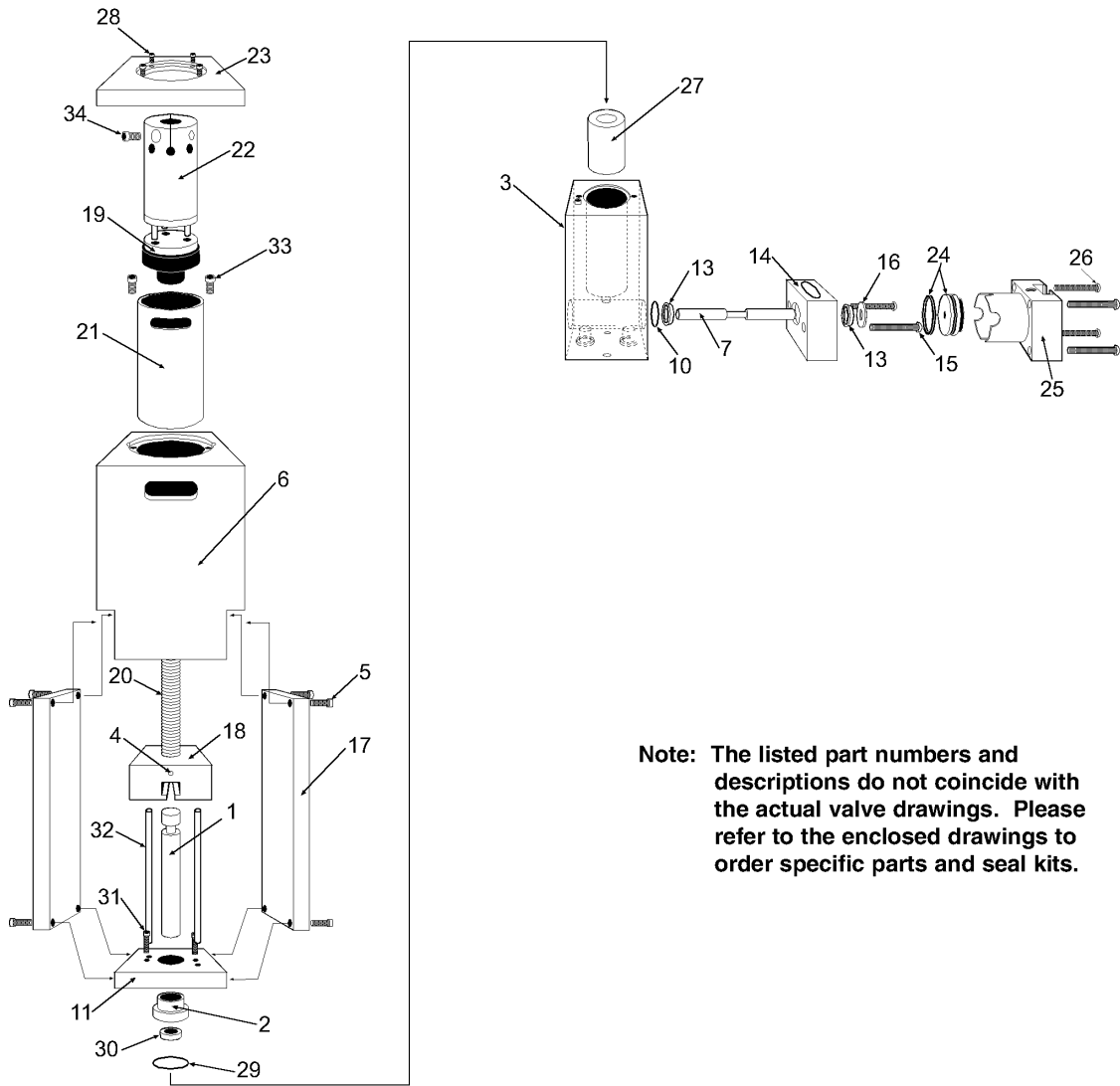

**Note:** The listed part numbers and descriptions do not coincide with the actual valve drawings. Please refer to the enclosed drawings to order specific parts and seal kits.

1	Metering Rod	14	Seal Plate (2)	24	Valve Piston (2)	34	Screw ('2)
2	Seal Cup	15	Screw (4)	25	Valve End Cap (2)		
3	Valve Body	16	Seal Retainer (2)	26	Screw (8)		
4	Screw (2)	17	Side Block (2)	27	Dispense Sleeve		
5	Screw (8)	18	Connection Block	28	Screw (4)		
6	Top Block	19	Lead Screw Nut	29	O-Ring		
7	Spool Rod	20	Lead Screw	30	Posipak Seal		
10	O-Ring (2)	21	Retaining Sleeve	31	Screw (2)		
11	Bottom Block	22	Motor Coupling	32	Guide Rod (2)		
13	Posipak Seal (4)	23	Mounting Plate	33	Screw (2)		

## Assembly

Before proceeding, remove any old o-rings or seals from the valve and discard, clean the valve parts with an appropriate solvent and replace o-rings and seals with new parts from seal kit. Use Krytox 203GPL (part number 84/0200-K3/11) for lubricating valve parts including seals and o-rings.

### Assembly Of 1053 Valve Section

**Note:** Check the Metering Rod (1), Dispense Sleeve (27), and Spool Assembly (7) for wear and if they are worn secure replacements before proceeding.

**Note:** Use caution as you install new U-cup and Posipak seals so that they are not pinched or torn. Do this by making sure they are lubricated, and by tucking the lips of the seal inward before uniformly pushing them into position.

1. Lubricate spool outer diameter.
2. Insert spool (7) carefully into the valve body (3), rocking it to ease it into place.

### Install the Seal Plates on the Main Body

3. Install a lubricated o-ring (10) on the left side of the Valve Body (3) next to the sleeve part of the Spool (7).
4. Install two lubricated Posipak Seals (13) in the left Seal Plate (14) so that the O-ring side of both Posipaks will be facing the Valve Body (3). Be sure to tuck the lip of the Posipak into its cavity to avoid tearing it.
5. Position the left Seal Plate (14) with the oil cup upwards and slide it over the Spool part of the Spool (7) with the counterbore for the Seal Retainer (16) facing out. Slide the Seal Retainer (16) over the Spool and install two Screws (15).
6. Repeat steps 3, 4 and 5 for the right side Seal Plates.

### Install the Dispense Sleeve and Connect the Motor & Motor Coupling Assembly

7. Lubricate the dispense sleeve bore in the Valve Body (3). Insert the Dispense Sleeve (27) into the Valve Body (3). Check for threads that may be in the inside of the sleeve due to tapping during removal and make sure these are at the top.

8. Place lubricated O-ring (29) over the Dispense Sleeve (27) and against the Valve Body (3).
9. Insert the Seal Cup (2) into the Bottom Block (11).
10. Slide a lubricated Posipak Seal (30) into the Seal Cup (2) with the o-ring side facing down.
11. Lubricate the Metering Rod (1) and slide it carefully through the Posipak Seal (30), Seal Cup (2) and Bottom Block (11) so that it projects about 1/2" through this assembly.
12. Using the projecting Metering Rod (1) to guide the assembly into the Dispense Sleeve (27), slide the Bottom Block (11) down against the Valve Body (3) and secure with Screws (31).
13. Pull the Metering Rod (1) away from the Valve Body (3) so that the end of it is only slightly in the Dispense Sleeve (27).
14. Slide the key slot in the Connection Block (18) over the end of the Metering Rod (1).
15. Insert the Guide Rods (13) through the Connection Block (18) and into the Bottom Block (11).

**Note:** If the Motor and Motor Coupling Assembly had been disassembled, then reassemble per the instructions below before proceeding with these next steps.

16. Position the Motor and Motor Coupling Assembly above the Valve Body Assembly and bring them together so that the Guide Rods (31) enter their holes in the Divorced Section (6) and the end of the Lead Screw (20) seats in the Connection Block (18).
17. Install the Screws (4) into the Connection Block (18) against the groove in the Lead Screw (20).
18. Install the left Side Block (17) with Screws (5). Insert the clear plastic Guards (not shown) into the slots in the left Side Block (17) so that the access hole in the guard is toward the top of the valve. Install the right Side Block (17) so that the Guards seat in the slots and secure with Screws (5).

### Mount the Valve End Caps to the Seal Plate Cups

19. Install a lubricated U-cup Seal (24) into the groove of the left Spool Shift Piston (24). The piston is thicker on one side of the groove. The lip of the seal must be facing the thicker section.

20. Lubricate the bore in the End Cap (25). Slide the Spool Shift Piston (24) into the left End Cap (25) tucking the lip of the U-cup seal (24) into the End Cap (25) carefully.
21. Install the Piston/End Cap onto the left Seal Plate (14) using four Screws (26). Tighten the screws in a cross pattern gradually to prevent binding due to misalignment (like you would tighten lug nuts on a car tire).
22. Push the Spool Rod (7) into the left side until it contacts the piston. Repeat steps 19 - 21 for the right side.
23. Install any removable needles that were previously removed.
24. If your valve has cycle detection, slide the cycle detection sensors into the slots on the end caps and secure with the set screws. Do not overtighten the set screws as the sensors may be damaged.
25. Connect the air lines.
26. Perform the Dry Run, Loading & Priming and Output Verification procedures. Perform Operation Adjustment procedures if required.

## Motor and Motor Coupling Assembly

Disconnect electrical power before servicing the motor and motor coupling assembly. Refer to the illustrations on the following page.

1. Assemble Motor Coupler (3) by inserting Roll Pins (5) and Screws (4).

**Note:** This step is only required if the motor coupler has been disassembled for service or removed from the motor.

2. Assemble Lead Screw Nut (6) with Bearing (9) and E-ring (8).
3. Thread Lead Screw (7) into Lead Screw Nut assembly until lead screw is flush with top of nut.
4. Slide Lead Screw & Nut Assembly into Divorced Section (11).
5. Slide Bearing Retaining Sleeve (2) into Divorced Section (11) taking care to line up the slots in the two pieces. Secure in place with Socket Head Cap Screws (10).
6. Secure Motor Mounting Plate (1) to Divorced Section using Socket Head Cap Screws (15).
7. Place Motor Coupler (3) on motor shaft and lightly snug Screws (4) leaving about  $\frac{1}{2}$ " of motor shaft visible between Motor Coupler and motor. Insert Motor Coupler (3) through Motor Mounting Plate (1), align 3 Roll Pins (5) and insert into Lead Screw Nut (6) and gently seat the motor.

**Note:** This step is only required if the motor coupler has been disassembled for service or removed from the motor.

8. Remove motor and motor coupler, tighten Screws (4) and reassemble securing motor to Motor Mounting Plate using Socket Head Cap Screws (14).

# Motor and Motor Coupling Illustration

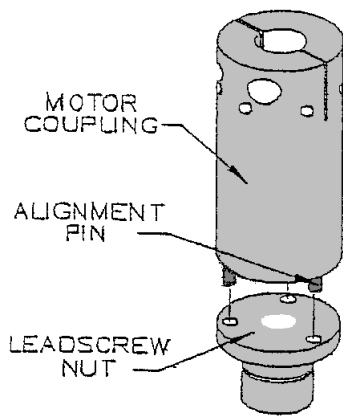

Pin Alignment

Ref	DESCRIPTION
1	MOTOR MOUNTING PLATE
2	BEARING RETAINING SLEEVE
3	MOTOR COUPLER
4	SCREW, SHC, #6-32x3/8
5	ROLL PIN, 1/8 DIA.x 1/2
6	LEAD SCREW NUT
7	LEAD SCREW
8	E-RING
9	BEARING
10	SCREW,SHC,#10-32x1/2
11	DIVORCED SECTION
12	METERING ROD CONNECTION BLOCK
13	SET SCREW, #8-32x3/16
14	SCREW,SHC,#10-32x1/2
15	SCREW,SHC,#6-32x 3/8

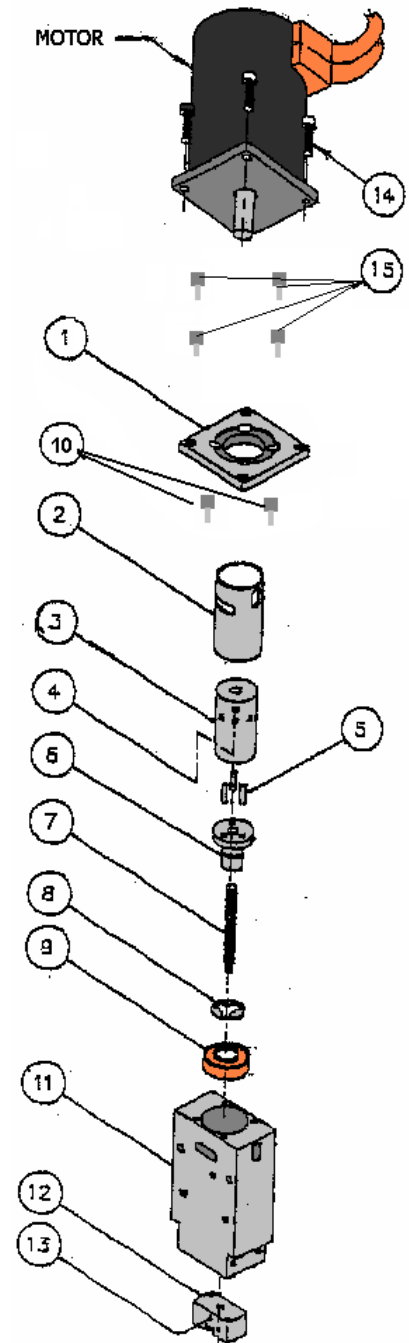

**Motor and Motor Coupling Installation.**  
 Location of the Motor shaft in the Motor Coupling is important for proper electrical control of the dispense valve.

# Electrical Requirements

See **Related Manuals** on page 2 for valve with controls/motor integrated.

Valve shown is with controls/motor not integrated. Valve with controls/motor integrated comes with LS-Home, solenoid - OPEN/CLOSE and all wires terminated at a plug.

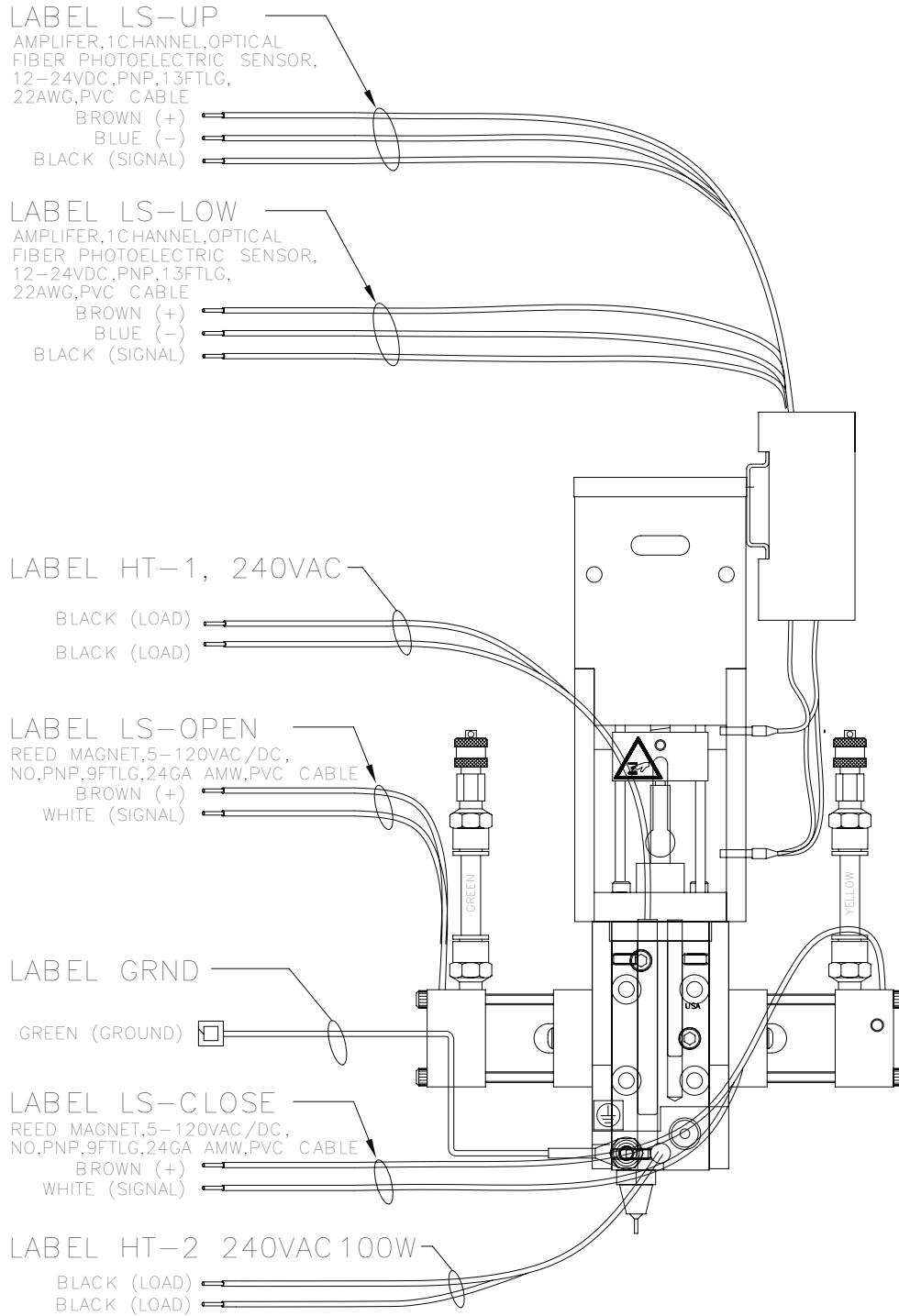

FIG. 8



# Technical Data

**NOTE:** See feed system manuals for dimensions, weights, and wetted parts lists for those components. Dimensions, weights, and wetted parts for components not covered in component feed system manuals and for combined assemblies are listed below.

Maximum Ambient Temperature . . . . .	110°F (43°C)
Maximum Operating Temp . . . . .	300°F (149°C)
Maximum Outlet Fluid Working Pressure . . . . .	2000 psi (14 MPa, 138 bar)
Maximum Air Working Pressure . . . . .	100 psi (0.7 MPa, 7 bar)
Minimum Air Working Pressure . . . . .	70 psi (480 kPa, 4.8 bar)
Maximum Material Inlet Pressure . . . . .	Metal Sleeves: 1200 psi (8 MPa, 83 bar)
Supplied Air Requirements . . . . .	1 to 3 cfm at 80 psi to 100 psi
Shot Size Range (depending on metering rods selected)	0.002 cc to 3.150 cc
Maximum Cycle Rate (application dependent, heat required) . . . . .	Up to 15 cycles per minute (with standard Graco motor)
Dimensions (H x L x W), height to end of material inlet block (less needles) . . . . .	1 in.: 14.83 x 6.23 x 2.91 in. (377 x 158 x 74 mm) 2 in.: 17.85 x 6.23 x 2.91 in. (453 x 158 x 74 mm) <i>Graco-supplied Feed System Assemblies</i> <i>(depends on selected options):</i> <i>Smallest:</i> 22.5 x 10 x 4 in. (572 x 254 x 102 mm) <i>Largest:</i> 60 x 28 x 19 in. (1524 x 711 x 483 mm)
Weight . . . . .	<i>Metering Valve:</i> 3 - 5 lb (1.36 - 2.27 kg) <i>with Standard Graco motor:</i> 7-9 lb (3.18 - 4.08 kg)
Wetted Parts . . . . .	<i>Metering Valve:</i> Hardened steel, 303/304, 404, UHM-WPE, Tungsten, carbide, fluoroelastomer, EPDM, PTFE <i>Graco-supplied Feed System Hoses and Fittings:</i> Mild steel, 303/304, PTFE, buna, polyethylene, polypropylene <i>Graco-supplied Tanks:</i> Polyethylene, 303/304, mild steel

## Motor Specifications

If a non-Graco motor is used with the Motor Driven model, it must meet the following specifications.

**Frame:** NEMA 23

**Torque at Typical Dispense Speed:** 180 oz-in. (11.25 in-lb) at 10 revolutions per second (1/2 in. rod travel per second) or less. Above 10 revolutions per second, the power declines.

**Torque at Maximum Speed:** 117 oz-in (7.3 in-lb) at 20 revolutions per second (1 in. of rod travel per second).

**Motor Face Pilot Boss:** 1.5 in. diameter by 0.0625 in. projection from motor face flange.

**Shaft Size:** 0.25 diameter by 0.75 in. projection from motor face pilot boss to end of shaft.

# Graco Standard Warranty

Graco warrants all equipment referenced in this document which is manufactured by Graco and bearing its name to be free from defects in material and workmanship on the date of sale to the original purchaser for use. With the exception of any special, extended, or limited warranty published by Graco, Graco will, for a period of twelve months from the date of sale, repair or replace any part of the equipment determined by Graco to be defective. This warranty applies only when the equipment is installed, operated and maintained in accordance with Graco's written recommendations.

This warranty does not cover, and Graco shall not be liable for general wear and tear, or any malfunction, damage or wear caused by faulty installation, misapplication, abrasion, corrosion, inadequate or improper maintenance, negligence, accident, tampering, or substitution of non-Graco component parts. Nor shall Graco be liable for malfunction, damage or wear caused by the incompatibility of Graco equipment with structures, accessories, equipment or materials not supplied by Graco, or the improper design, manufacture, installation, operation or maintenance of structures, accessories, equipment or materials not supplied by Graco.

This warranty is conditioned upon the prepaid return of the equipment claimed to be defective to an authorized Graco distributor for verification of the claimed defect. If the claimed defect is verified, Graco will repair or replace free of charge any defective parts. The equipment will be returned to the original purchaser transportation prepaid. If inspection of the equipment does not disclose any defect in material or workmanship, repairs will be made at a reasonable charge, which charges may include the costs of parts, labor, and transportation.

**THIS WARRANTY IS EXCLUSIVE, AND IS IN LIEU OF ANY OTHER WARRANTIES, EXPRESS OR IMPLIED, INCLUDING BUT NOT LIMITED TO WARRANTY OF MERCHANTABILITY OR WARRANTY OF FITNESS FOR A PARTICULAR PURPOSE.**

Graco's sole obligation and buyer's sole remedy for any breach of warranty shall be as set forth above. The buyer agrees that no other remedy (including, but not limited to, incidental or consequential damages for lost profits, lost sales, injury to person or property, or any other incidental or consequential loss) shall be available. Any action for breach of warranty must be brought within two (2) years of the date of sale.

**GRACO MAKES NO WARRANTY, AND DISCLAIMS ALL IMPLIED WARRANTIES OF MERCHANTABILITY AND FITNESS FOR A PARTICULAR PURPOSE, IN CONNECTION WITH ACCESSORIES, EQUIPMENT, MATERIALS OR COMPONENTS SOLD BUT NOT MANUFACTURED BY GRACO.** These items sold, but not manufactured by Graco (such as electric motors, switches, hose, etc.), are subject to the warranty, if any, of their manufacturer. Graco will provide purchaser with reasonable assistance in making any claim for breach of these warranties.

In no event will Graco be liable for indirect, incidental, special or consequential damages resulting from Graco supplying equipment hereunder, or the furnishing, performance, or use of any products or other goods sold hereto, whether due to a breach of contract, breach of warranty, the negligence of Graco, or otherwise.

## **FOR GRACO CANADA CUSTOMERS**

The Parties acknowledge that they have required that the present document, as well as all documents, notices and legal proceedings entered into, given or instituted pursuant hereto or relating directly or indirectly hereto, be drawn up in English. Les parties reconnaissent avoir convenu que la rédaction du présente document sera en Anglais, ainsi que tous documents, avis et procédures judiciaires exécutés, donnés ou intentés, à la suite de ou en rapport, directement ou indirectement, avec les procédures concernées.

# Graco Information

For the latest information about Graco products, visit [www.graco.com](http://www.graco.com).

For patent information, see [www.graco.com/patents](http://www.graco.com/patents).

**TO PLACE AN ORDER**, contact your Graco distributor or call to identify the nearest distributor.

**Toll Free:** 1-800-746-1334 **or Fax:** 330-966-3006

*All written and visual data contained in this document reflects the latest product information available at the time of publication. Graco reserves the right to make changes at any time without notice.*

*Original instructions. This manual contains English. MM 3A0874*

**Graco Headquarters:** Minneapolis

**International Offices:** Belgium, China, Japan, Korea

**GRACO OHIO INC. 8400 PORT JACKSON AVE NW, NORTH CANTON, OH 44720**

Copyright 2010, Graco Ohio Inc. is registered to ISO 9001

[www.graco.com](http://www.graco.com)

Revised November 2013