

GH™ 200, EH™ 200, EH™ 200 HDI, EH™ 200 DI DutyMax, EH™ 300 DI DutyMax Electric Motor Kit

310812K
EN

- For use with architectural coatings and paints -



IMPORTANT SAFETY INSTRUCTIONS.
Read all warnings and instructions in this manual. Save these instructions.

3300 psi (22.8 MPa, 228 bar) Maximum Working Pressure

288473: 120 Vac, 60 Hz, 15A

GH130 Sprayer Electric Motor Kit

288474: 120 Vac, 60 Hz, 20A

Same as 288473 except with ETL approval to CSA and UL standards

248949: 120 Vac, 60 Hz, 15A

GH200/GH230 Sprayer Electric Motor Kit

248950: 120 Vac, 60 Hz, 20A

Same as 248949 except with ETL approval to CSA and UL standards

248946: 220 Vac, 50 Hz, 13.4A

EH200/EH200HDI Sprayer Electric Motor Kit

24M668: 220 Vac, 50 Hz, 15.0A

EH200DI Sprayer DutyMax

24M669: 400 Vac, 50 Hz, 11.0A

EH300DI Sprayer DutyMax

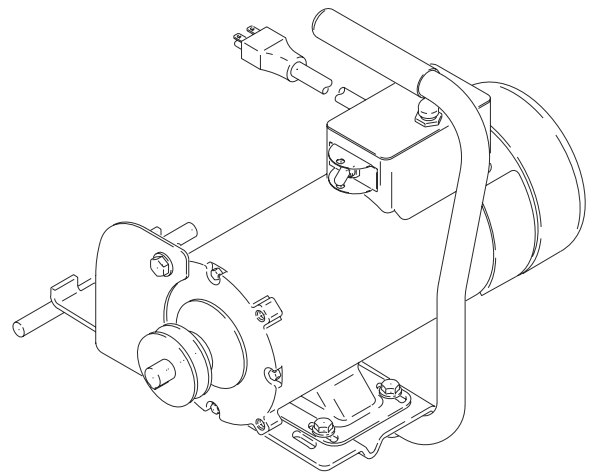

Warnings

The following warnings are for the setup, use, grounding, maintenance, and repair of this equipment. The exclamation point symbol alerts you to a general warning and the hazard symbols refer to procedure-specific risks. When these symbols appear in the body of this manual, refer back to these Warnings. Product-specific hazard symbols and warnings not covered in this section may appear throughout the body of this manual where applicable.

WARNING

FIRE AND EXPLOSION HAZARD



Flammable fumes, such as solvent and paint fumes, in work area can ignite or explode. To help prevent fire and explosion:



- Use equipment only in well ventilated area.
- Eliminate all ignition sources; such as pilot lights, cigarettes, portable electric lamps, and plastic drop cloths (potential static arc).
- Sprayer generates sparks. When flammable liquid is used in or near the sprayer or for flushing or cleaning, keep sprayer at least 20 feet (6 m) away from explosive vapors.
- Keep work area free of debris, including solvent, rags and gasoline.
- Do not plug or unplug power cords or turn lights on or off when flammable fumes are present.
- Ground equipment and conductive objects in work area. Read **Grounding** instructions.
- If there is static sparking or you feel a shock, **stop operation immediately**. Do not use equipment until you identify and correct the problem.
- Keep a working fire extinguisher in the work area.

Grounding



Improper installation or alteration of the grounding plug will result in a risk of electric shock, fire or explosion that could cause serious injury or death.

The sprayer must be grounded. Grounding reduces the risk of static and electric shock by providing an escape wire for the electrical current due to static build up or in the event of a short circuit.

- 120 Vac: requires a 120 Vac, 60 Hz, 20A (15A for 248949) circuit with a grounding receptacle (A). 230 Vac: requires a 230 Vac, 50 Hz, 13A circuit with a grounding receptacle (A). Never use an outlet that is not grounded (A) or an adapter.

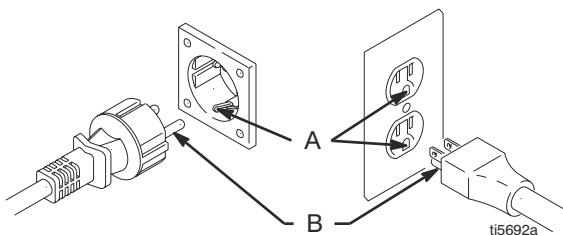

- Do not use sprayer if electric cord has a damaged ground prong (B). Only use an extension cord with an undamaged 3-prong plug.

Recommended extension cord lengths:

- 25 ft (7.6 m) 18 AWG
- 50 ft (15.2 m) 16 AWG
- 100 ft (30.5 m) 14 AWG
- 150 ft (45.7 m) 12 AWG

Smaller gauge or longer cords may reduce sprayer performance.

- If the power cord or plug is damaged, replace with the appropriate cord listed in the **Parts List**.

Power Requirements

- 380-400V units require 400 VAC, 50 Hz, 16A, 3 phase, 3P+N+E, 6H power connection
- To operate the EH300DI (24M056) sprayer, the generator needs to be sized for 15 kW output (minimum).

Pulley Placement

Sprayer Models:

248559, 248560, 248561, 248565, 248566, 248568, 253709, 253957, 253959, 253980, 253960, 253962, 253963, 253981, 253964, 253965, 253966, 253982

Align pulley (4) approximately 0.20 in. from end of electric motor shaft.

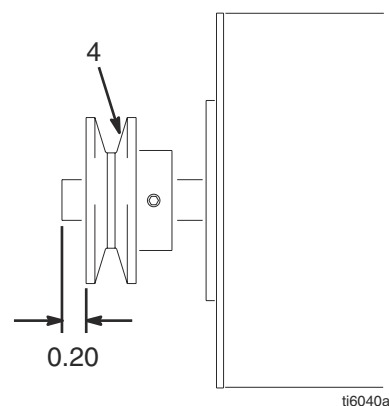

Models:

233940, 233941, 233942, 233943, 248946, 24M668, 24M669

Align pulley (4) at end of electric motor shaft.

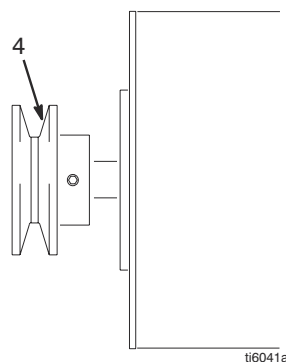

Parts - 288473, 288474, 248949, 248950

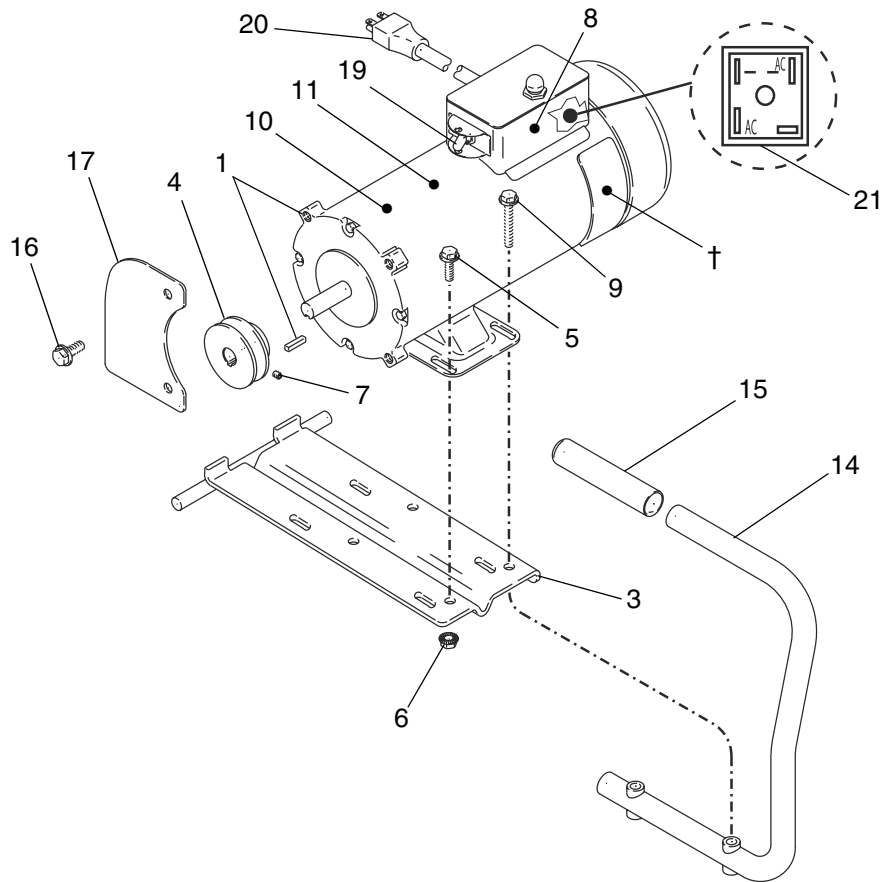

Ref.	Part	Description	Qty.	Ref.	Part	Description	Qty.
1 †		ELECTRIC MOTOR		16	111192	SCREW, cap, flange hd	2
	246129	NON-CSA, 2.0 HP, includes 19	1	17	15B562	BRACKET, guard, motor	1
	246125	CSA, 2.0 HP, includes 19	1	18	176347	LABEL, identification	1
3	198838	BRACKET, mount, engine	1	19	287145	SWITCH, breaker	1
4	15A752	PULLEY, 2.5 in. (Models 248949, 248950)	1	20	196836	CORD, power	1
	15J953	PULLEY, 4.25 in. (Models 288473, 288474)	1	21	111419	RECTIFIER, bridge	1
5	112586	SCREW, cap, hex hd	2	▲ Warning labels, tags, and cards are free.			
6	110996	NUT, flanged, hex	4	† Brush Repair Kit 220853 is available for 248949, 288473			
7	100002	SCREW, set	2	Brush Repair Kit 287737 is available for 248950, 288474			
8▲		LABEL, warning					
	187975	NON-CSA	1				
	193096	CSA	1				
9	114653	SCREW, cap, hex hd	2				
10▲	189285	LABEL, danger, (English)	1				
	195805	LABEL, danger, (French)	1				
14	246214	HANDLE, conversion	1				
15	111700	GRIP, handle	1				

Wiring Diagram for 196836 Power Cord

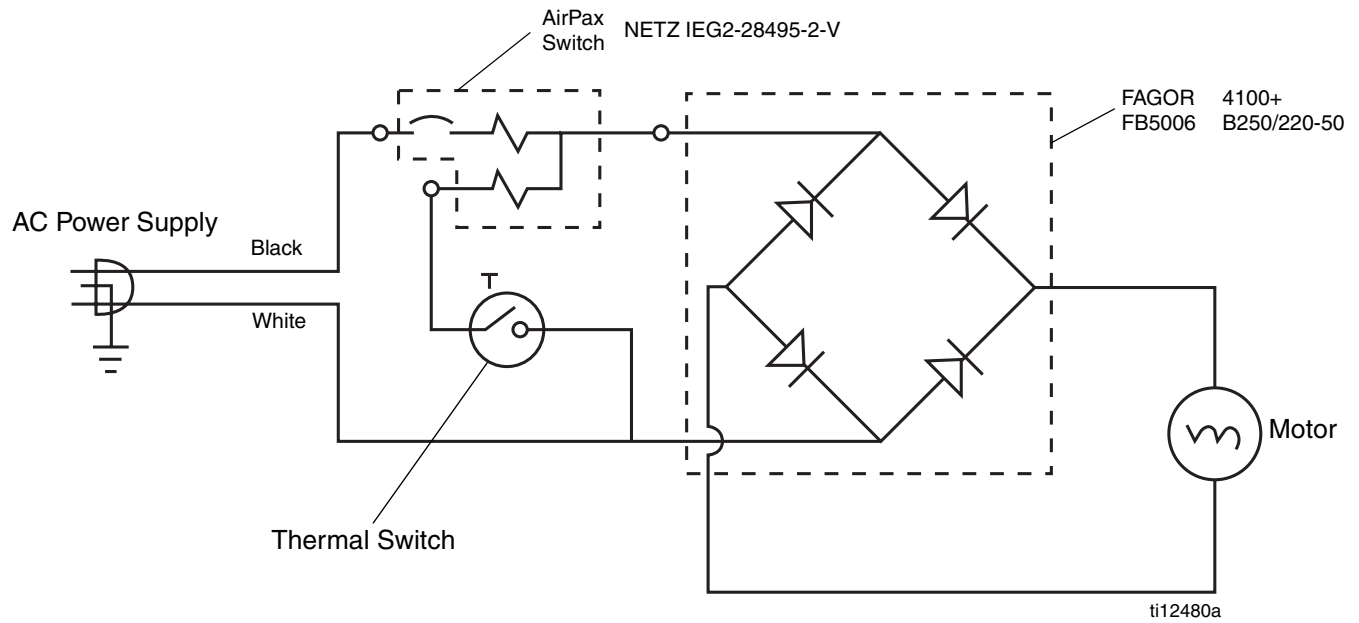

Wiring Diagram for 24M669 (400 Vac)

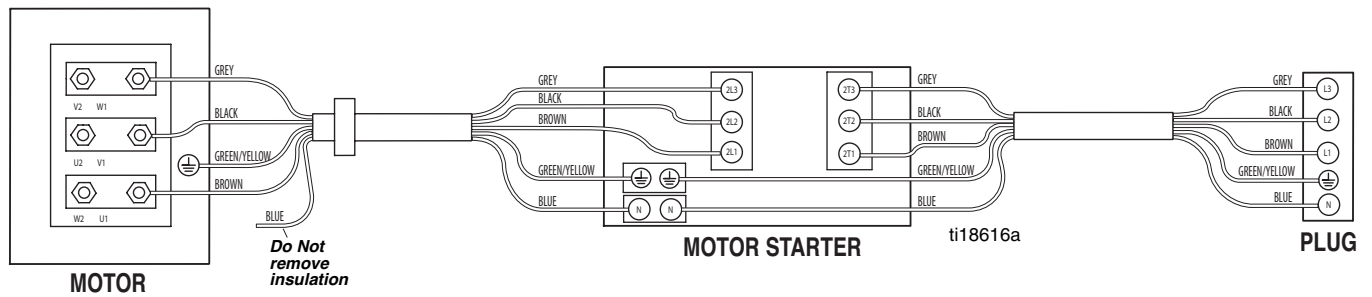

Parts 248946, 24M668

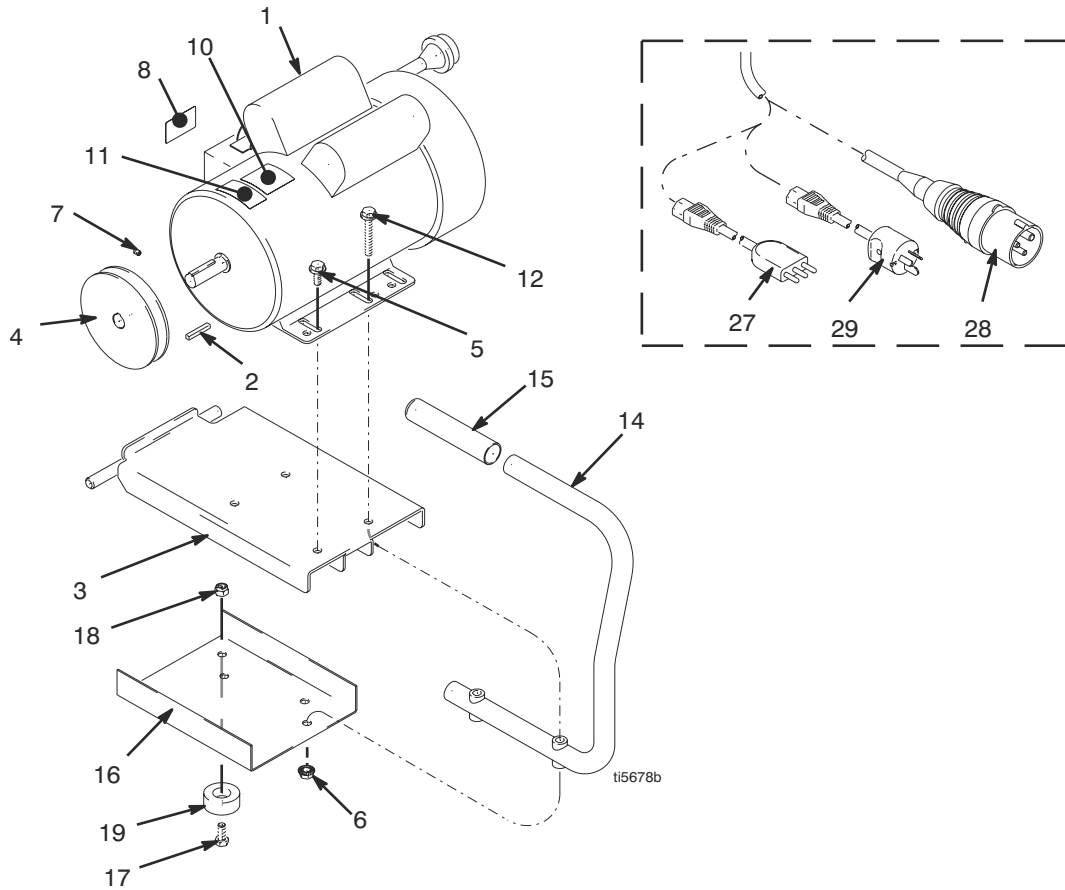

Ref.	Part	Description	Qty.	Ref.	Part	Description	Qty.
1	15E669	ELECTRIC MOTOR 3.0 HP, 220 Vac	1	14	246214	HANDLE, conversion	1
2	117632	KEY, square, 3/16 x 1.25 in	1	15	111700	GRIP, handle	1
3	15E585	BRACKET, mount, engine	1	16	15F217	PLATE	1
4	15E588	PULLEY, 2.5 in. (Model 248946)	1	17	100057	SCREW	4
	16N612	PULLEY, 4.95 in. (Model 24M668)	1	18	111040	NUT	4
5	110963	SCREW, cap, hex hd	2	19	113817	BUMPER	4
6	110996	NUT, flanged, hex	4	27	197186	PLUG, Italian, rewirable	1
7	100002	SCREW, set	2	28	197187	PLUG, IEC 309, 16/20A, 3-pin	1
8▲	187975	LABEL, warning (Model 248946)	1	29	197188	PLUG, Australian, rewirable	1
	189930	LABEL, warning (Model 24M668)	1	32	116914	BELT, vee, gripnotch (not shown) (Model 24M668)	1
10	15B804	LABEL, Graco, logo	1				
11	290228	LABEL, caution (Model 248946)	1				
	15K616	LABEL, caution (Model 24M668)	1				
12	114653	SCREW, cap, hex hd	1				

▲ Warning labels, tags, and cards are free.

Breaker Switch Repair Kit 287744 is available.

Capacitors Repair Kit 287746 is available.

Parts - 24M669

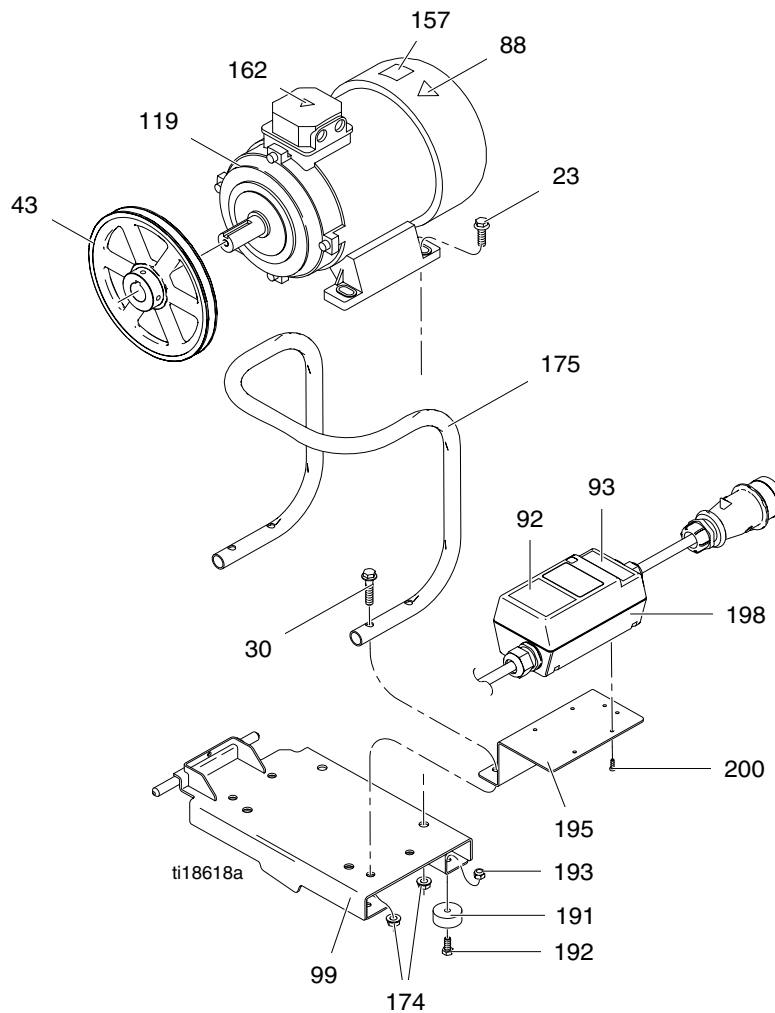

Ref.	Part	Description	Qty.	Ref.	Part	Description	Qty.
23	111193	SCREW, cap flange hd	4	174	112958	NUT, hex, flanged	8
30	116780	SCREW, hex, hd, flanged	4	175	16M473	TUBE, handle, conversion	1
43	125811	PULLEY, cast iron, 8.75 in	1	191	113817	BUMPER	4
88▲	15K616	LABEL	1	192	100057	SCREW, cap, hex hd	4
92	16N399	LABEL, motor switch box on-off	1	193	111040	NUT, lock, insert, nylock, 5/16	4
93	16N400	LABEL, red light indicator	1	195	16M474	BRACKET, motor starter	1
99	16M467	BRACKET, mounting, motor, EH 300	1	198	24N064	STARTER, motor, assembly	1
119	24N019	MOTOR, elec., 400 VAC, 50 HZ, 7.3 hp	1	200	119236	SCREW, plastite	4
162▲	189930	LABEL, caution	1				

▲ Warning labels are available at no cost.

Graco Standard Warranty

Graco warrants all equipment referenced in this document which is manufactured by Graco and bearing its name to be free from defects in material and workmanship on the date of sale to the original purchaser for use. With the exception of any special, extended, or limited warranty published by Graco, Graco will, for a period of twelve months from the date of sale, repair or replace any part of the equipment determined by Graco to be defective. This warranty applies only when the equipment is installed, operated and maintained in accordance with Graco's written recommendations.

This warranty does not cover, and Graco shall not be liable for general wear and tear, or any malfunction, damage or wear caused by faulty installation, misapplication, abrasion, corrosion, inadequate or improper maintenance, negligence, accident, tampering, or substitution of non-Graco component parts. Nor shall Graco be liable for malfunction, damage or wear caused by the incompatibility of Graco equipment with structures, accessories, equipment or materials not supplied by Graco, or the improper design, manufacture, installation, operation or maintenance of structures, accessories, equipment or materials not supplied by Graco.

This warranty is conditioned upon the prepaid return of the equipment claimed to be defective to an authorized Graco distributor for verification of the claimed defect. If the claimed defect is verified, Graco will repair or replace free of charge any defective parts. The equipment will be returned to the original purchaser transportation prepaid. If inspection of the equipment does not disclose any defect in material or workmanship, repairs will be made at a reasonable charge, which charges may include the costs of parts, labor, and transportation.

THIS WARRANTY IS EXCLUSIVE, AND IS IN LIEU OF ANY OTHER WARRANTIES, EXPRESS OR IMPLIED, INCLUDING BUT NOT LIMITED TO WARRANTY OF MERCHANTABILITY OR WARRANTY OF FITNESS FOR A PARTICULAR PURPOSE.

Graco's sole obligation and buyer's sole remedy for any breach of warranty shall be as set forth above. The buyer agrees that no other remedy (including, but not limited to, incidental or consequential damages for lost profits, lost sales, injury to person or property, or any other incidental or consequential loss) shall be available. Any action for breach of warranty must be brought within two (2) years of the date of sale.

GRACO MAKES NO WARRANTY, AND DISCLAIMS ALL IMPLIED WARRANTIES OF MERCHANTABILITY AND FITNESS FOR A PARTICULAR PURPOSE, IN CONNECTION WITH ACCESSORIES, EQUIPMENT, MATERIALS OR COMPONENTS SOLD BUT NOT MANUFACTURED BY GRACO. These items sold, but not manufactured by Graco (such as electric motors, switches, hose, etc.), are subject to the warranty, if any, of their manufacturer. Graco will provide purchaser with reasonable assistance in making any claim for breach of these warranties.

In no event will Graco be liable for indirect, incidental, special or consequential damages resulting from Graco supplying equipment hereunder, or the furnishing, performance, or use of any products or other goods sold hereto, whether due to a breach of contract, breach of warranty, the negligence of Graco, or otherwise.

FOR GRACO CANADA CUSTOMERS

The Parties acknowledge that they have required that the present document, as well as all documents, notices and legal proceedings entered into, given or instituted pursuant hereto or relating directly or indirectly hereto, be drawn up in English. Les parties reconnaissent avoir convenu que la rédaction du présente document sera en Anglais, ainsi que tous documents, avis et procédures judiciaires exécutés, donnés ou intentés, à la suite de ou en rapport, directement ou indirectement, avec les procédures concernées.

*All written and visual data contained in this document reflects the latest product information available at the time of publication.
Graco reserves the right to make changes at any time without notice.*

For patent information, see www.graco.com/patents.

Original instructions. This manual contains English. MM 310812

Graco Headquarters: Minneapolis
International Offices: Belgium, China, Japan, Korea

GRACO INC. AND SUBSIDIARIES • P.O. BOX 1441 • MINNEAPOLIS MN 55440-1441 • USA

Copyright 2012, Graco Inc. All Graco manufacturing locations are registered to ISO 9001.

www.graco.com
Revised May 2012