

Hydra-Clean[®] Packages

312585G
EN

Package solutions for pressure washing applications. For use only with water and cleaning solutions. For professional use only.



Important Safety Instructions

Read all warnings and instructions in this manual and in your respective pump manual. Save these instructions.

See page 3 for model information, including maximum working pressure.

Cart Mount Packages

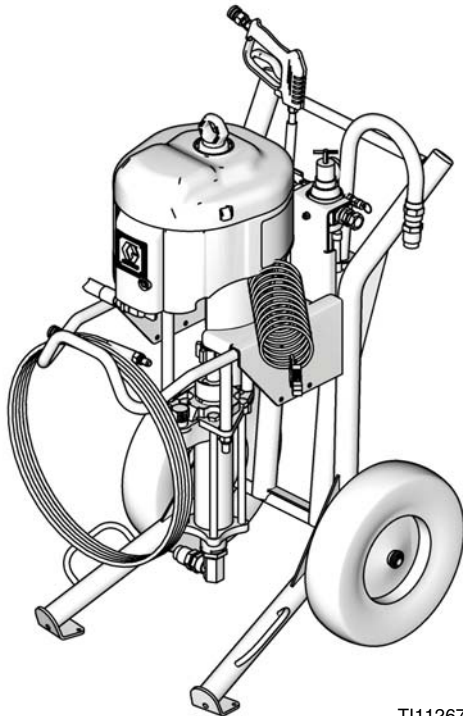

TI11267b

Wall Mount Packages

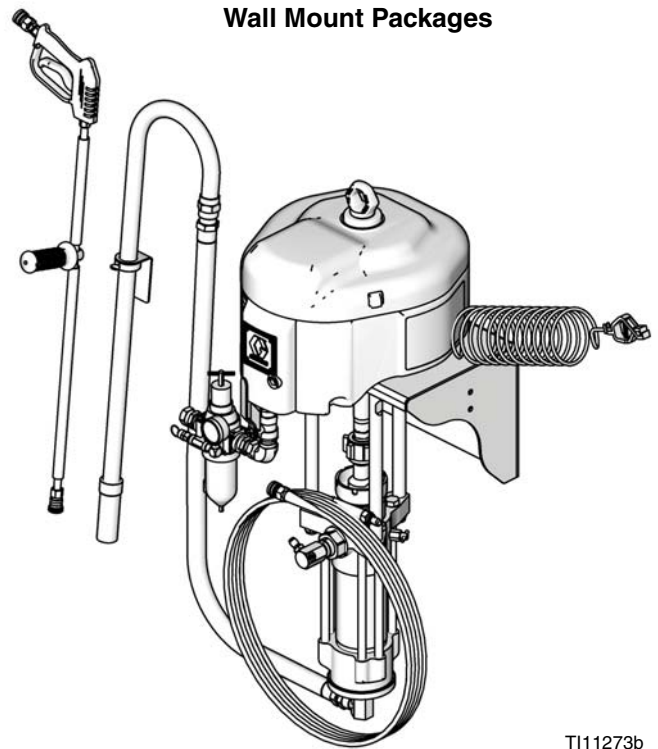

TI11273b



Contents

Models	3
Related Manuals	3
Warnings	4
Installation	6
Wall Mount Packages	6
Flush Before Using Equipment	6
Integrated Air Control Module	6
Grounding	8
Operation	9
Pressure Relief Procedure	9
Cleaning Solutions	9
Flushing	9
Starting the Pump	10
Adjusting the Pump	10
Troubleshooting	12
Repair	13
Disconnect the Displacement Pump	13
Reconnect the Displacement Pump	13
Parts	14
247549 Cart Mount Package	14
247550 Wall Mount Package	15
247551, 247553, and 258664 Cart Mount Packages	16
247552, 247554, and 258665 Wall Mount Packages	17
Parts Listings	18
Air Regulator Assemblies	20
24E013, for Cart-Mount Models	20
24E025, for Wall-Mount Models	20
Kits	21
Wall Mounting Bracket Diagram	22
Dimensions	23
Pump Performance Tables	24
Technical Data	27
Graco Standard Warranty	28
Graco Information	28

Models

Check your package's identification plate (ID) for the 6-digit part number of your package. To order replacement parts, see **Parts** starting on page 14.

 All packages include air controls, hose and gun, and ground wire.

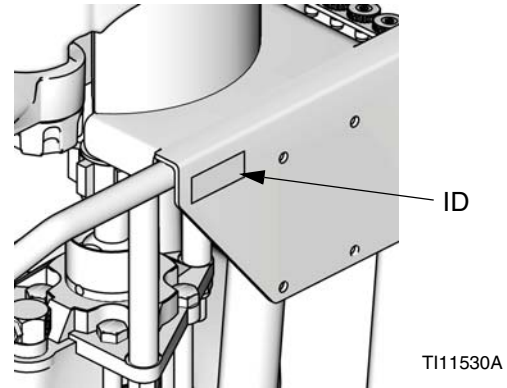





Part No.	Series	Maximum Working Pressure psi (MPa, bar)	Maximum Air Input Pressure psi (MPa, bar)	Ratio	Displacement Pump Size (cc per cycle)	Includes:	
						Portable Cart	Wall Mount
247549	C	1250 (8.6, 86.2)	100 (0.7, 7.0)	12:1	550 cc	✓	
247550	C	1250 (8.6, 86.2)	100 (0.7, 7.0)	12:1	550 cc		✓
247551	C	2275 (15.7, 156.9)	100 (0.7, 7.0)	23:1	580 cc	✓	
247552	C	2275 (15.7, 156.9)	100 (0.7, 7.0)	23:1	580 cc		✓
247553	C	3065 (21.1, 211.3)	100 (0.7, 7.0)	30:1	430 cc	✓	
247554	C	3065 (21.1, 211.3)	100 (0.7, 7.0)	30:1	430 cc		✓
258664	C	4000 (27.6, 275.8)	100 (0.7, 7.0)	40:1	290 cc	✓	
258665	C	4000 (27.6, 275.8)	100 (0.7, 7.0)	40:1	290 cc		✓

Related Manuals





Manual	Description
312745	247599 Displacement Pump
311825	Dura-Flo Displacement Pump; 1800 and 2400
311827	Dura-Flo Displacement Pump; 600, 750, 900, and 1200
311238	NXT Air Motor
3A0293	Air Controls
308511	Hydra-Clean Spray Gun

Warnings

The following warnings are for the setup, use, grounding, maintenance, and repair of this equipment. The exclamation point symbol alerts you to a general warning and the hazard symbol refers to procedure-specific risk. Refer back to these warnings. Additional, product-specific warnings may be found throughout the body of this manual where applicable.

 WARNING	
	<p>FIRE AND EXPLOSION HAZARD</p> <p>Flammable fumes, such as solvent and paint fumes, in work area can ignite or explode. To help prevent fire and explosion:</p> <ul style="list-style-type: none"> • Use equipment only in well ventilated area. • Eliminate all ignition sources; such as pilot lights, cigarettes, portable electric lamps, and plastic drop cloths (potential static arc). • Keep work area free of debris, including solvent, rags and gasoline. • Do not plug or unplug power cords, or turn power or light switches on or off when flammable fumes are present. • Ground all equipment in the work area. See Grounding instructions. • Use only grounded hoses. • Hold gun firmly to side of grounded pail when triggering into pail. • If there is static sparking or you feel a shock, stop operation immediately. Do not use equipment until you identify and correct the problem. • Keep a working fire extinguisher in the work area.
	<p>EQUIPMENT MISUSE HAZARD</p> <p>Misuse can cause death or serious injury.</p> <ul style="list-style-type: none"> • Do not operate the unit when fatigued or under the influence of drugs or alcohol. • Do not exceed the maximum working pressure or temperature rating of the lowest rated system component. See Technical Data in all equipment manuals. • Use fluids and solvents that are compatible with equipment wetted parts. See Technical Data in all equipment manuals. Read fluid and solvent manufacturer's warnings. For complete information about your material, request MSDS forms from distributor or retailer. • Check equipment daily. Repair or replace worn or damaged parts immediately with genuine manufacturer's replacement parts only. • Do not alter or modify equipment. • Use equipment only for its intended purpose. Call your distributor for information. • Route hoses and cables away from traffic areas, sharp edges, moving parts, and hot surfaces. • Do not kink or over bend hoses or use hoses to pull equipment. • Keep children and animals away from work area. • Comply with all applicable safety regulations.
	<p>SKIN INJECTION HAZARD</p> <p>High-pressure fluid from gun, hose leaks, or ruptured components will pierce skin. This may look like just a cut, but it is a serious injury that can result in amputation. Get immediate surgical treatment.</p> <ul style="list-style-type: none"> • Do not point gun at anyone or at any part of the body. • Do not put your hand over the spray tip. • Do not stop or deflect leaks with your hand, body, glove, or rag. • Do not spray without tip guard and trigger guard installed. • Engage trigger lock when not spraying. • Follow Pressure Relief Procedure in this manual, when you stop spraying and before cleaning, checking, or servicing equipment.

 **WARNING**

	<p>MOVING PARTS HAZARD</p> <p>Moving parts can pinch or amputate fingers and other body parts.</p> <ul style="list-style-type: none"> • Keep clear of moving parts. • Do not operate equipment with protective guards or covers removed. • Pressurized equipment can start without warning. Before checking, moving, or servicing equipment, follow the Pressure Relief Procedure in this manual. Disconnect power or air supply.
 	<p>TOXIC FLUID OR FUMES HAZARD</p> <p>Toxic fluids or fumes can cause serious injury or death if splashed in the eyes or on skin, inhaled, or swallowed.</p> <ul style="list-style-type: none"> • Read MSDS's to know the specific hazards of the fluids you are using. • Store hazardous fluid in approved containers, and dispose of it according to applicable guidelines. • Always wear impervious gloves when spraying or cleaning equipment.
	<p>PERSONAL PROTECTIVE EQUIPMENT</p> <p>You must wear appropriate protective equipment when operating, servicing, or when in the operating area of the equipment to help protect you from serious injury, including eye injury, inhalation of toxic fumes, burns, and hearing loss. This equipment includes but is not limited to:</p> <ul style="list-style-type: none"> • Protective eyewear • Clothing and respirator as recommended by the fluid and solvent manufacturer • Gloves • Hearing protection

Installation

The Graco warranty will not apply if cleaning solutions other than those recommended by Graco are used in these units. Only use solutions that are not harmful to the wetted parts. See the Technical Data in the displacement pump manuals 311825, 311827, and 312745.

See FIG. 1. Connect the suction hose (P) between the pump fluid inlet and the suction tube (R), using thread sealant on the male threads. Screw on the suction tube strainer. Place the suction tube in the supply drum, and adjust it so it is 1 in. (25 mm) off the bottom of the drum. Tighten the thumbscrew of the pipe hanger onto the drum.

Connect the spray hose (S) to the pump outlet manifold. For two gun spraying, remove the plug in the manifold and connect another spray hose. Connect the spray gun (T) to the hose (S). Use thread sealant on the male threads.

Wall Mount Packages

1. Ensure the wall is strong enough to support the weight of the pump assembly and accessories, fluid, hoses, and stress caused during pump operation.
2. Ensure that the mounting location has sufficient clearance for easy operator access.
3. Position the wall bracket at a convenient height, ensuring that there is sufficient clearance for the fluid suction line and for servicing the displacement pump.
4. Drill four 7/16 in. (11 mm) holes using the bracket as a template. Use any of the three mounting hole groupings in the bracket. See **Wall Mounting Bracket Diagram**, page 22.
5. Bolt the bracket securely to the wall using bolts and washers designed to hold in the wall's construction.
6. Attach the pump assembly to the mounting bracket.
7. Connect air and fluid hoses.





Flush Before Using Equipment

The equipment was tested with lightweight oil, which is left in the fluid passages to protect parts. To avoid contaminating your fluid with oil, flush the equipment with a compatible solvent before using the equipment. See your respective pump manual. See **Related Manuals** on page 3.

Air Controls

See FIG. 1. Air Controls are included with all packages. The following parts are included (see 3A0293 for detailed information):

- **Bleed-type master air valve (D):** required in your system to relieve air trapped between it and the air motor when the valve is closed.

						
Trapped air can cause the pump to cycle unexpectedly, which could result in serious injury from splashing or moving parts.						

- **Pump regulator assembly (E):** The regulator adjusts air pressure to the motor and fluid outlet pressure of pump. View the gauge (F) to read air pressure. The filter removes harmful contaminants from entering the air control module and air motor.
- **Safety relief valve (G):** automatically opens to relieve air pressure, to prevent pump overpressurization.

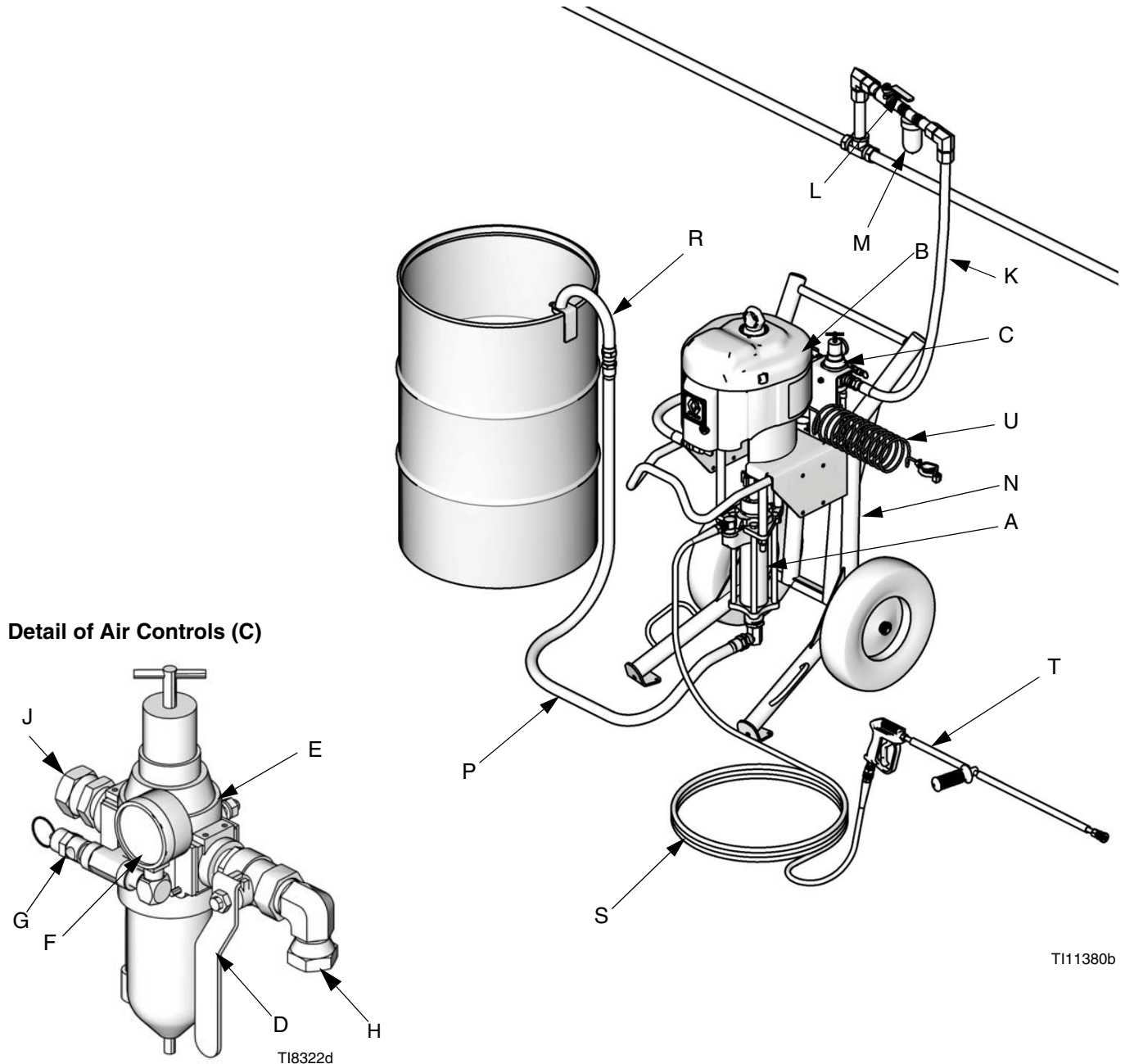

T111380b

FIG. 1: Typical Installation (Cart Mount Package Shown)

- | | | | |
|---|--|---|---------------------------------|
| A | Displacement Pump | N | Portable Cart |
| B | Air Motor | P | Fluid Suction Hose |
| C | Air Controls (includes items D-G) | R | Fluid Suction Tube and Strainer |
| D | Bleed-type Master Air Valve (required) | S | Fluid Spray Hose |
| E | Pump Air Regulator Assembly | T | Spray Gun and Wand |
| F | Air Pressure Gauge | U | Ground Wire (required) |
| G | Safety Relief Valve | | |
| H | Air Outlet to Pump | | |
| J | Air Inlet | | |
| K | Air Line to Air Controls | | |
| L | Air Line Shutoff Valve | | |
| M | Air Line Filter | | |

Grounding

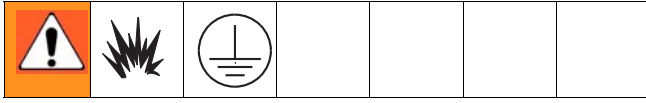

Although water generally provides a natural electrical ground, the following equipment must be grounded if the cleaning chemicals are volatile.

The equipment must be grounded. Grounding reduces the risk of static and electric shock by providing an escape wire for the electrical current due to static build up or in the event of a short circuit.

When cleaning in enclosed areas, such as storage tanks, locate the pump and air compressor outside the area and well away from it. Provide adequate ventilation. If the area you are cleaning has stored flammable materials, take appropriate precautions to avoid static sparking. Consult your local codes.

Pump: use supplied ground wire and clamp. See FIG. 2. Use the ground screw (GS) and lockwasher (LW) to attach the ground wire (U) at the rear of the air motor. Tighten the screw securely. Connect the other end of the ground wire to a true earth ground.

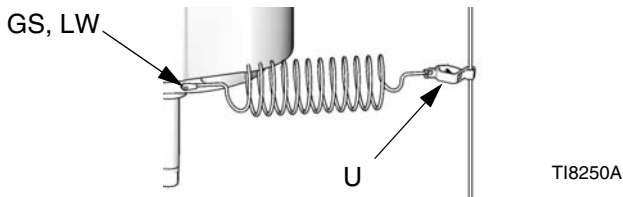

FIG. 2. Ground Wire

Air and fluid hoses: use only electrically conductive hoses.

Air compressor: follow manufacturer's recommendations.

Spray gun / Dispense valve: ground through connection to a properly grounded fluid hose and pump.

Fluid supply container: follow local code.





Object being sprayed: follow local code.

Solvent pails used when flushing: follow local code. Use only conductive metal pails, placed on a grounded surface. Do not place the pail on a nonconductive surface, such as paper or cardboard, which interrupts grounding continuity.

To maintain grounding continuity when flushing or relieving pressure: hold metal part of the spray gun/dispense valve firmly to the side of a grounded metal pail, then trigger the gun/valve.

Operation





Pressure Relief Procedure

						
Trapped air can cause the pump to cycle unexpectedly, which could result in serious injury from splashing or moving parts.						





1. Engage the trigger lock.
2. Close the bleed-type master air valve to shutoff the pump.
3. Disengage the trigger lock.
4. Hold a metal part of the gun firmly to a grounded metal pail. Trigger the gun to relieve pressure.
5. Engage the trigger lock.
6. Open all fluid drain valves in the system, having a waste container ready to catch drainage. Leave the drain valve(s) open until you are ready to spray again.
7. If you suspect the spray tip or hose is clogged or that pressure has not been fully relieved after following the steps above, VERY SLOWLY loosen the tip guard retaining nut or hose end coupling to relieve pressure gradually, then loosen completely. Clear the hose or tip obstruction.

Cleaning Solutions

Prepare the cleaning solution according to the manufacturer's instructions. Be sure to observe all warnings. If you are using powdered cleaners, mix them thoroughly in a separate pail before adding them to a supply drum. Undissolved powders are extremely abrasive and may damage pump parts.

						
Wear appropriate protective clothing, such as waterproof outerwear and eye goggles, according to the cleaner manufacturer's recommendations. Cleaning chemicals may be toxic, and cause serious irritation to your eyes or skin.						

Flushing

						
To reduce the risk of fluid injection injury, static sparking, or splashing, relieve the pressure, and remove the spray tip (spray guns only) before flushing.						

Hold a metal part of the gun/valve firmly to the side of a grounded metal pail and use the lowest possible fluid pressure during flushing.

Starting the Pump

1. Open the bleed-type master air valve (A).
2. Trigger the gun into a grounded metal pail, holding a metal part of the gun firmly to the pail.
3. Slowly open the air regulator (E) until the pump starts running.
4. Run the pump slowly until all the air is purged, release the gun trigger, and lock the trigger safety - the pump will start and stop as the gun is opened and closed.

Adjusting the Pump

- Always use the lowest pressure necessary to get the desired results.
- Never allow the pump to run dry of fluid being pumped. A dry pump will quickly accelerate to a high speed, possibly damaging itself. If your pump accelerates quickly, or is running too fast, stop it immediately and check the fluid supply. If the supply container is empty and air has been pumped into lines, prime the pump and lines with fluid, or flush and leave filled with a compatible solvent. Be sure to eliminate all air from the fluid system.
- The piston and intake check valves of displacement pump 247599 are factory-set for light viscosity fluids. This setting minimizes surging at pump stroke changeover. To adjust the valves for heavier viscosity fluids, see manual 312745.
- Always stop the pump at the bottom of its stroke to prevent fluid from drying on the rod and damaging the throat packings. When you finish pumping, always relieve the pressure, page 9.
- If you are pumping fluid which dries, hardens, or sets up, flush the system with a compatible solvent as often as necessary to prevent a build up of dried fluid in the pump or hoses.
- Every 40 hours of operation, check that the packing nut is tight. Relieve the pressure, page 9. Then, tighten the packing nut just snug - do not overtighten or the packings may be damaged.

Troubleshooting

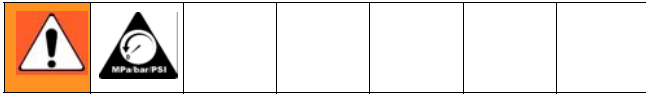

1. Relieve the pressure, page 9.
2. Check all possible causes and problems before disassembling the pump.

Problem	Cause	Solution
Pump fails to operate.	Restricted line or inadequate air supply; closed or clogged valves.	Clear; increase air supply. Check that valves are open.
	Obstructed fluid hose or gun/valve; fluid hose ID is too small.	Open, clear*; use hose with larger ID.
	Fluid dried on displacement rod.	Clean; always stop pump at bottom of stroke; keep wet-cup 1/3 filled with compatible solvent.
	Dirty, worn, or damaged motor parts.	Clean or repair. See manual 311238.
Pump operates, but output low on both strokes.	Restricted line or inadequate air supply; closed or clogged valves.	Clear; increase air supply. Check that valves are open.
	Obstructed fluid hose or gun/valve; fluid hose ID is too small.	Open, clear*; use hose with larger ID.
	Bleeder valve open.	Close.
	Worn packings in displacement pump.	Replace packings. See displacement pump manual 311825 or 312745.
Pump operates, but output low on downstroke.	Held open or worn intake valve.	Clear valve; service. See displacement pump manual 311825 or 312745.
Pump operates, but output low on upstroke.	Held open or worn piston valve or packings.	Clear valve; replace packings. See displacement pump manual 311825 or 312745.
Erratic or accelerated pump speed.	Exhausted fluid supply.	Refill and prime.
	Held open or worn piston valve or packings.	Clear valve; replace packings. See displacement pump manual 311825 or 312745.
	Held open or worn intake valve.	Clear valve; service. See displacement pump manual 311825 or 312745.

* To determine if the fluid hose or gun is obstructed, relieve the pressure, page 9. Disconnect the fluid hose and place a container at the pump fluid outlet to catch any fluid. Turn on the air power just enough to start the pump. If the pump starts, the obstruction is in the fluid hose or gun.

Repair

Disconnect the Displacement Pump

See the **Parts** drawings on pages 14-17.

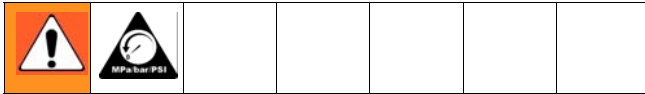

1. Flush the pump, if possible. Stop the pump at the bottom of its stroke. Relieve the pressure, page 9.
2. Disconnect the air, fluid, and suction hoses.

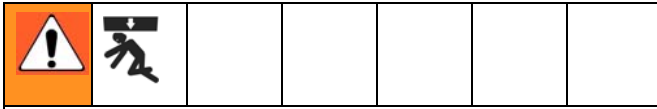

Do not lift the pump by the lift ring when the total weight exceeds 250 kg (550 lb).

Use at least two people when lifting, moving, or disconnecting the pump. If disconnecting the displacement pump, be sure to securely brace the pump, or have two people hold it while another disconnects it.



Before disconnecting the displacement pump (10) from the motor (6), be sure to note the relative position of the pump's fluid outlet to the air inlet of the motor. If the motor does not require servicing, leave it attached to its mounting.

3. Unscrew the coupling nut (14) from the connecting rod adapter (11). Remove the coupling collars (13); do not lose or drop them.
4. Hold the tie rod flats with a wrench to keep the rods (9) from turning. Unscrew the nuts (12). Remove the displacement pump (10).
5. To service the displacement pump, refer to manual 311825, 311827, or 312745, supplied. To service the air motor, refer to manual 311238, supplied.

Reconnect the Displacement Pump

See the **Parts** drawings on pages 14-17.

1. Screw the connecting rod adapter (11) to the air motor shaft.
2. Screw the tie rods (9) into the air motor (6). Using a wrench on the tie rod flats, torque to 50-60 ft-lb (68-81 N•m).
3. Make sure the coupling nut (14) and coupling collars (13) are in place on the displacement rod.
4. Use at least two people to hold the displacement pump while another reconnects it to the motor (see the **WARNING** at left). Orient the pump's fluid outlet to the air inlet as noted under **Disconnect the Displacement Pump**. Place the displacement pump (10) on the tie rods (9).
5. Screw the nuts (12) onto the tie rods (9) and torque to 50-60 ft-lb (68-81 N•m).
6. Screw the coupling nut (14) onto the connecting rod adapter (11) loosely. Hold the connecting rod adapter flats with a wrench to keep it from turning. Use an adjustable wrench to tighten the coupling nut. Torque to 90-100 ft-lb (121-135 N•m).
7. Reconnect all hoses. Reconnect the ground wire if it was disconnected. Fill the wet-cup 1/3 full of Graco Throat Seal Liquid or compatible solvent.
8. Turn on the air supply. Run the pump slowly to ensure that it operates properly.

Parts

247549 Cart Mount Package

See parts listing on page 18.

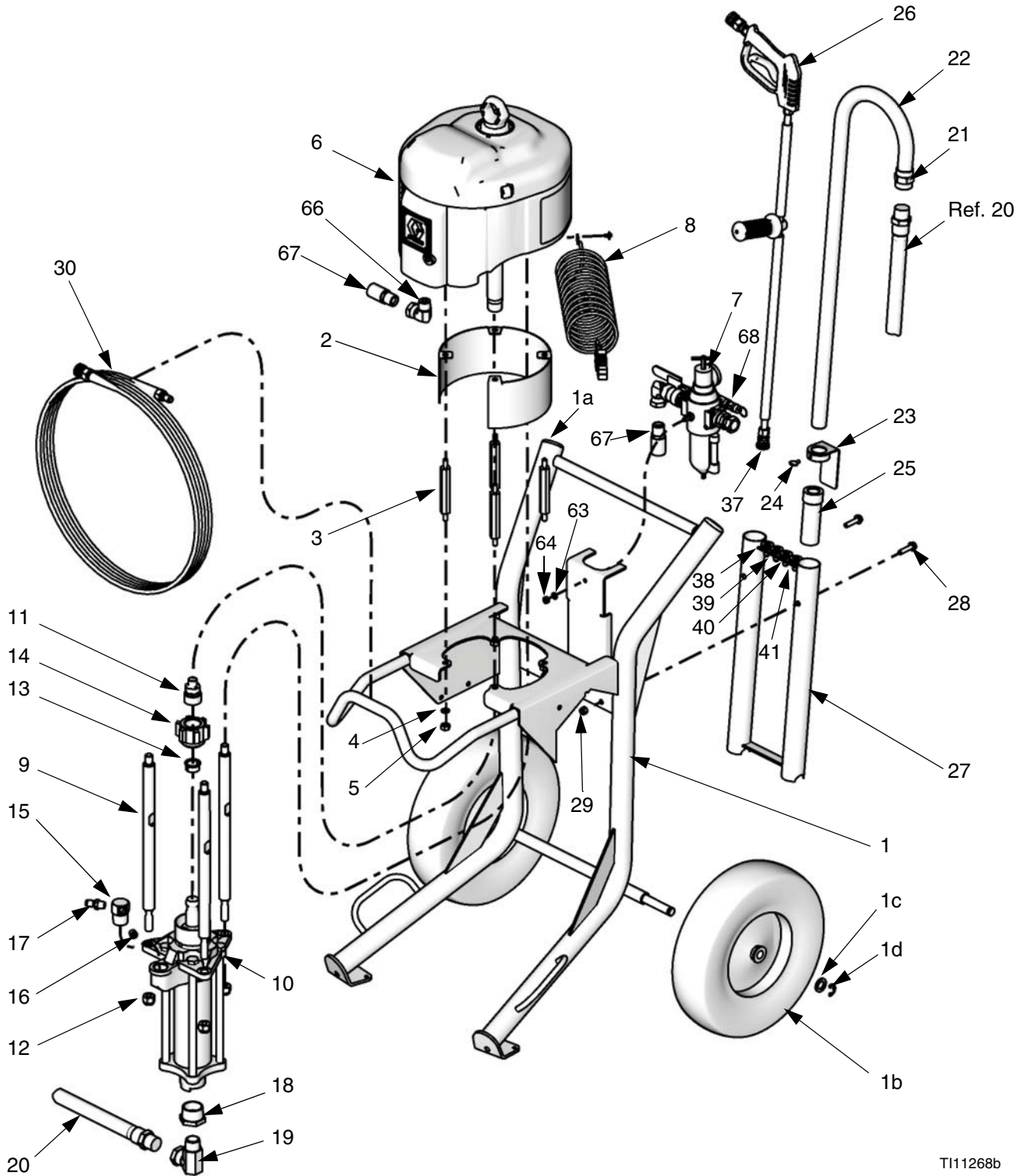

T11268b

247550 Wall Mount Package

See parts listing on page 18.

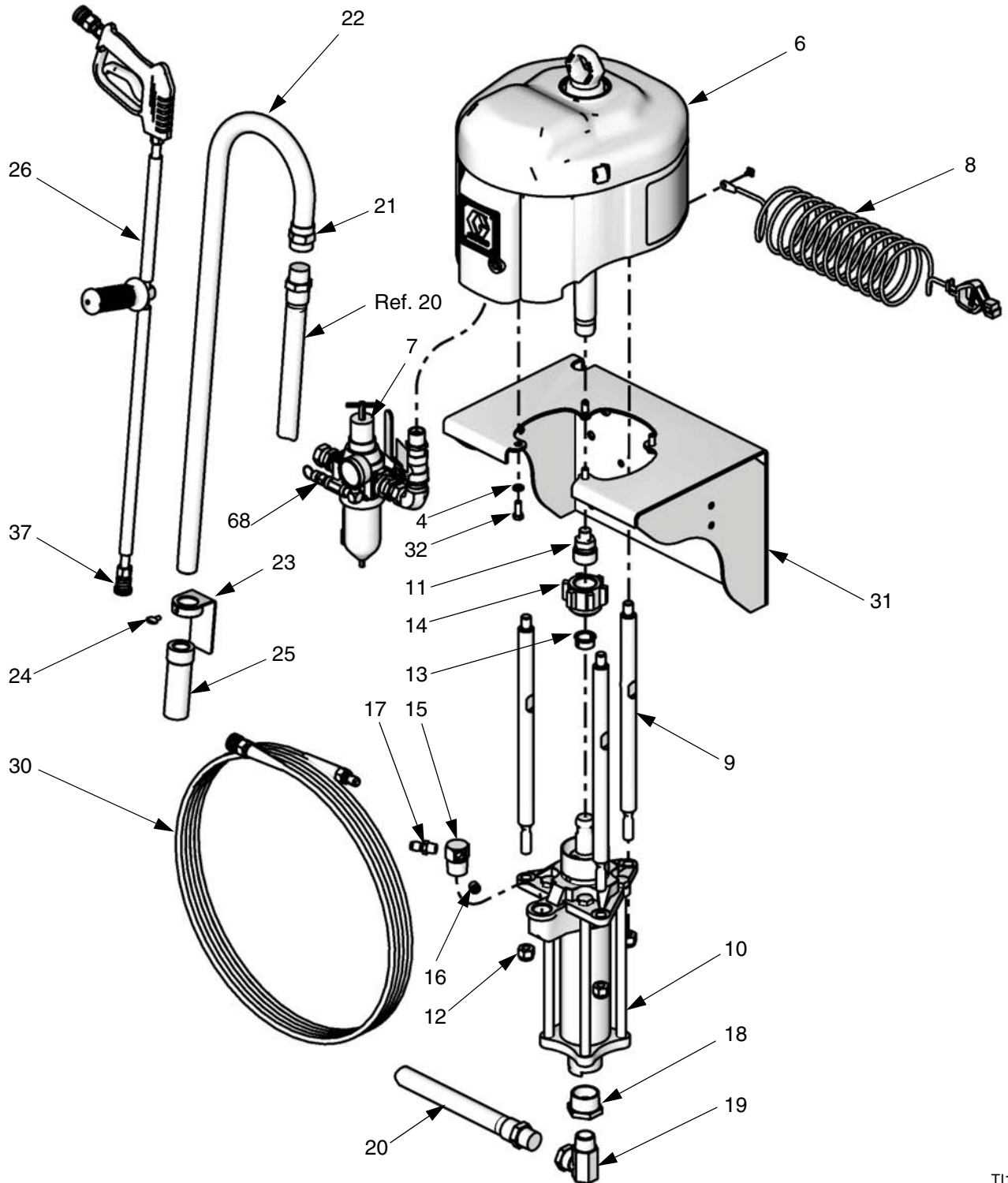

TI11270b

247551, 247553, and 258664 Cart Mount Packages

See parts listing on page 18.

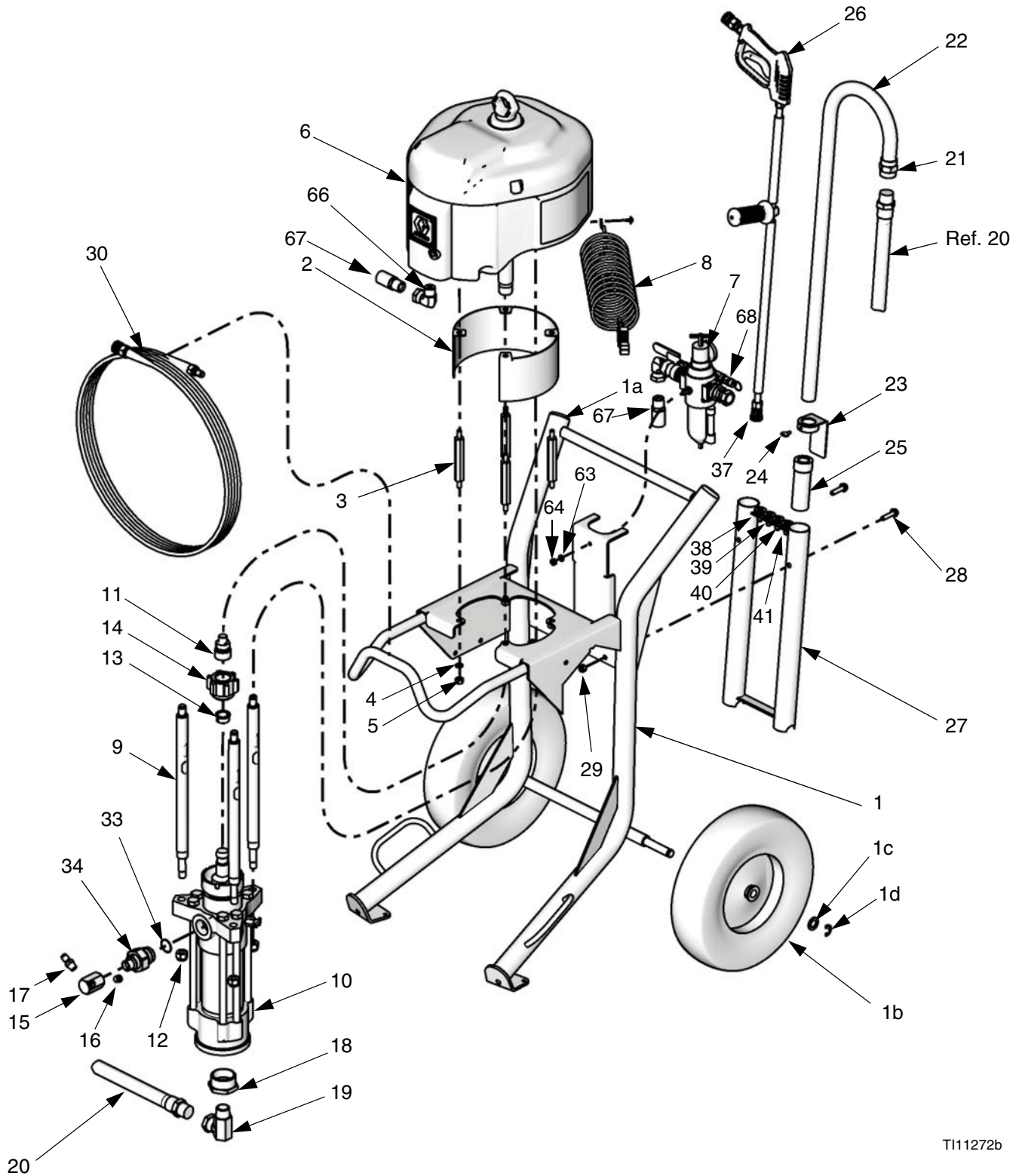

TI11272b

247552, 247554, and 258665 Wall Mount Packages

See parts listing on page 18.

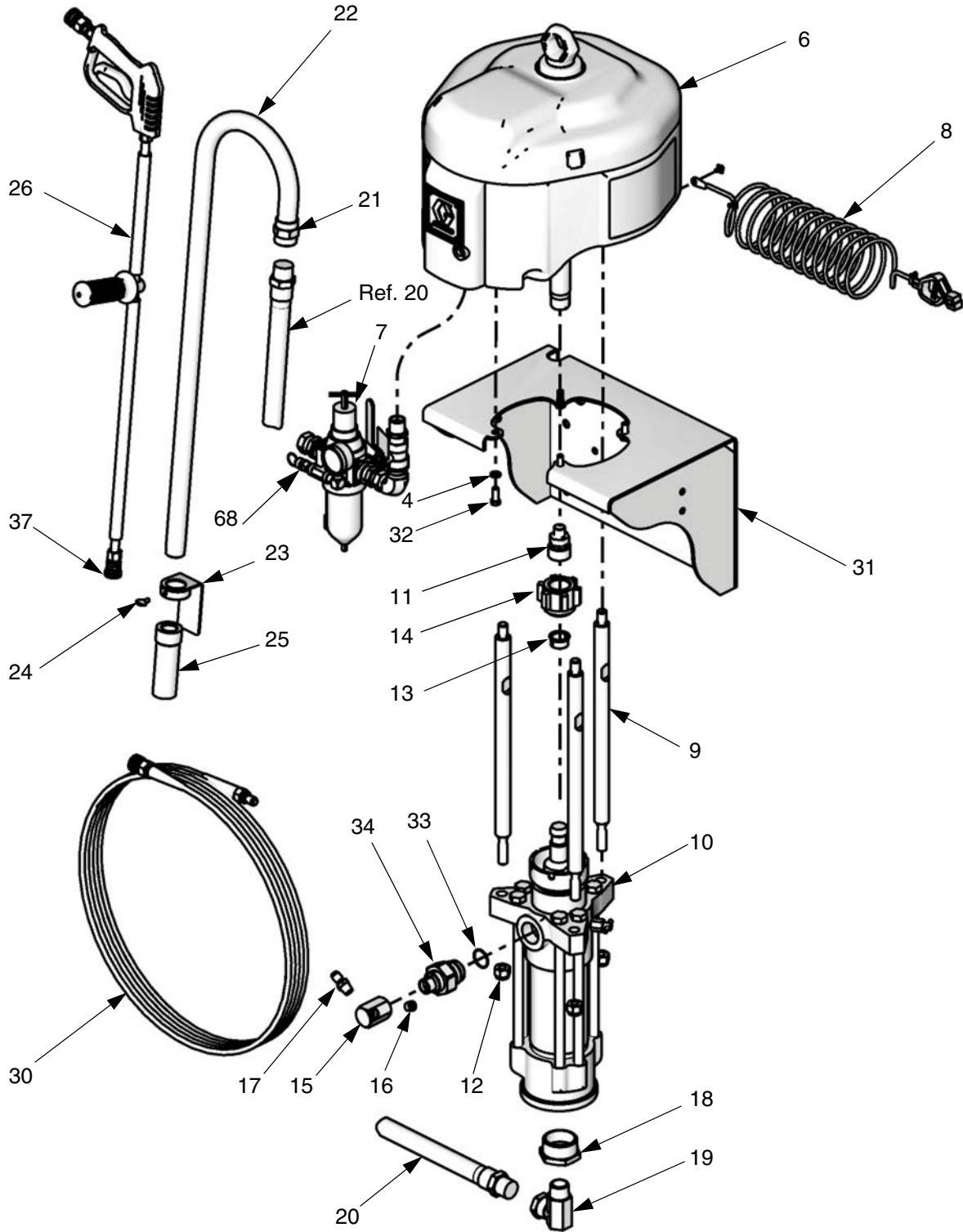

TI11274b

Parts Listings

Common Parts

The following parts except #39, are used on all packages in this manual.

Ref.	Part	Description	Qty.	Ref.	Part	Description	Qty.
4	100133	WASHER, lock; 3/8	4	30	247878	HOSE, fluid; 3/8 in. (10 mm) ID;	1
8	244524	WIRE, ground	1			sst quick disconnect fittings (m x f);	
12	101712	NUT, lock; 5/8-11	3			50 ft (15.2 m)	
16	101748	PLUG, pipe; 3/8 npt; sst	1	37	805584	TIP, spray, Q-type; 15090†	1
17	15T272	COUPLING, quick release; 3/8 npt	1	38	805538	TIP, spray, Q-type; 40030†	1
19	15T273	SWIVEL; 90°; 1 in. npt(m) x 1 in. npsm(f)	1	39*	805575	TIP, spray, Q-type; 00080 †	1
20	214959	HOSE, suction; 1 in. (25 mm) ID; 1 in. npt(m) sst fittings; 6 ft (1.83 m); nylon	1	40	805549	TIP, spray, Q-type; 25045†	1
21	166629	COUPLING; 1 in. npt(fbe)	1	41*	805566	TIP, spray, Q-type; 40065 †	1
22	166630	TUBE, suction; 1 in. (25 mm) ID; 1 in. npt(mbe); brass	1	68	113498	VALVE, safety, 110 psi (0.76 MPa, 7.6 bar)	1
23	205770	HANGER, pipe	1	*Assemblies 258664 and 258665 do not include item 39 and contain Qty. 2 of item 41.			
24	100085	SCREW, thumb; 1/4-20 x 1/2 in. (13 mm)	1	† The first two digits designate the fan angle. The last three digits designate the orifice size in thousandths of an inch.			
25	15T284	STRAINER, fluid inlet; 60 mesh	1				
26	247879	GUN, wand; sst and brass; includes 32 in. (813 mm) sst wand; see 308511	1				

Parts that Vary by Package

Ref. No.	Description	Package Part Nos.								Qty
		247549	247550	247551	247552	247553	247554	258664	258665	
1	CART; includes items 1a-1d	287884		287884		287884		287884		1
1a	CAP, tube, round	113361		113361		113361		113361		2
1b	WHEEL, semi-pneumatic	113362		113362		113362		113362		2
1c	WASHER; 3/4 in. (19 mm) ID	buy locally		buy locally		buy locally		buy locally		2
1d	RING, retaining	113436		113436		113436		113436		2
2	SPACER	15K296		15K296		15K296		15K296		1
3	SPACER, mounting	120465		120465		120465		120465		4
5	NUT, hex; 3/8-16	100131		100131		100131		100131		4
6	MOTOR, air; see 311238	N34DN0	N34DN0	N65DN0	N65DN0	N65DN0	N65DN0	N65DN0	N65DN0	1
7	REGULATOR, air, assembly; see page 20.	24E013	24E025	24E013	24E025	24E013	24E025	24E013	24E025	1
9	ROD, tie; 14.656 in. (372 mm) shoulder to shoulder	15T274	15T274							3
	ROD, tie; 15.4 in. (391 mm) shoulder to shoulder			15H562	15H562	15H562	15H562	15H562	15H562	3

Ref. No.	Description	Package Part Nos.								Qty
		247549	247550	247551	247552	247553	247554	258664	258665	
10	PUMP, displacement; see 312745	247599	247599							1
	PUMP, displacement; see 311825			241648	241648					1
	PUMP, displacement; see 311825					687055	687055			1
	PUMP, displacement; see 311827							24B923	24B923	1
11	ADAPTER; M38 x 2 x 3/4-16 unf	15H371	15H371	15H371	15H371	15H371	15H371			1
	ADAPTER; 1 1/4-12 unf x 3/4-16 unf							15H370	15H370	1
13	COLLAR, coupling	184130	184130	184130	184130	184130	184130	184129	184129	2
14	NUT, coupling	184096	184096	184096	184096	184096	184096	186925	186925	1
15	MANIFOLD, fluid outlet; 1 in. npt(m) x 3/8 npt(f) x 3/8 npt(f)	166444	166444					166444	166444	1
	MANIFOLD, fluid outlet; 3/4 npt(f) x 3/8 npt(f) x 3/8 npt(f); sst			15T275	15T275	15T275	15T275			1
18	BUSHING; 1-1/2 in. npt(m) x 1 in. npt(f); sst	15T271	15T271							1
	BUSHING; 2 in. npt(m) x 1 in. npt(f)			102283	102283	102283	102283	102283	102283	1
27	HOLDER, tube and gun; includes items 28 and 29	247622		247622		247622		247622		1
28	SCREW, machine, hex; 1/4-20 x 1 in. (25 mm)	113428		113428		113428		113428		2
29	NUT, lock, hex; 1/4-20; sst	109478		109478		109478		109478		2
31	WALL MOUNT BRACKET; includes items 4 and 32; see 311619		255143		255143		255143		255143	1
32	SCREW, cap, socket-hd; 3/8-16 x 1 in. (25 mm)		100101		100101		100101		100101	4
33	O-RING; PTFE			109213	109213	109213	109213			1
34	FITTING, outlet; M42 x 2.0 x 3/4 npt(m); sst			15B316	15B316	15B316	15B316			1
63	WASHER, lock	107542		107542		107542		107542		1
64	NUT, keps, hex; M8 x 1.25	113761		113761		113761		113761		1
66	ELBOW; 90°, 3/4-14 nps(m) x 3/4-14 npt(f)	160327		160327		160327		160327		1
67	HOSE, coupled, 30 in. (76 cm)	240900		240900		240900		240900		1

Air Regulator Assemblies

24E013, for Cart-Mount Models

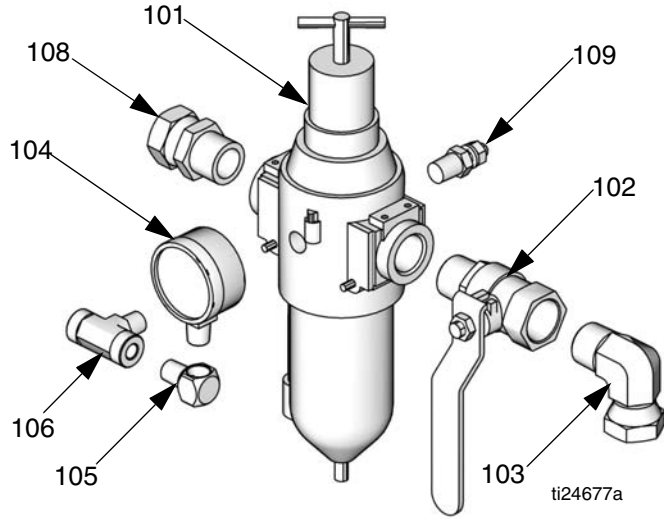

Ref.	Part	Description	Qty.
101	116521	FILTER/REGULATOR, air	1
102	113218	VALVE, ball, vented, 3/4-14 npt	1
103	160327	ELBOW; 90°, 3/4-14 nps(m) x 3/4-14 npt(f)	1
104	100960	GAUGE, air pressure	1
105	100840	ELBOW, street, 1/4-18 npt	1
106	108638	TEE, pipe, 1/4-18 npt	1
108	157785	SWIVEL, 3/4-14 nps x 3/4-14 npt	1
109	194545	CONNECTOR, bulkhead	1

24E025, for Wall-Mount Models

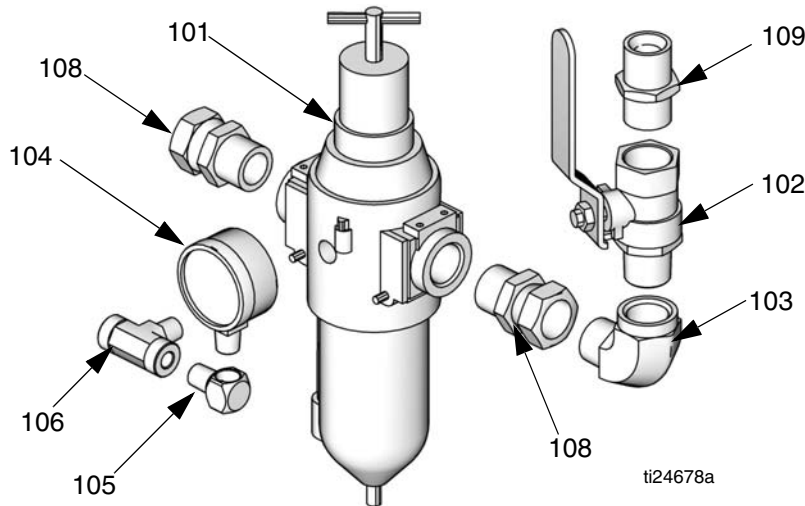

Ref.	Part	Description	Qty.
101	116521	FILTER/REGULATOR, air	1
102	113218	VALVE, ball, vented, 3/4-14 npt	1
103	122327	ELBOW; 90°, 3/4-14 nps(m) x 3/4-14 npt(f)	1
104	100960	GAUGE, air pressure	1
105	100840	ELBOW, street, 1/4-18 npt	1
106	108638	TEE, pipe, 1/4-18 npt	1
108	157785	SWIVEL, 3/4-14 nps x 3/4-14 npt	2
109	160032	NIPPLE, 3/4 npt	1

Kits

Bare Gun Replacement Kits

- 15T283, Brass Spray Gun (standard)
- 15T282, Stainless Steel Spray Gun (optional)

Gun Stainless Steel Fitting Kit

- 247880, includes stainless steel gun inlet and outlet fittings

Gun Wand Replacement Kits

- 15T279, 32 in. (813 mm) Stainless Steel Wand (standard)
- 15T280, 10 in. (254 mm) Stainless Steel Wand (optional)

Wall Mounting Bracket Diagram

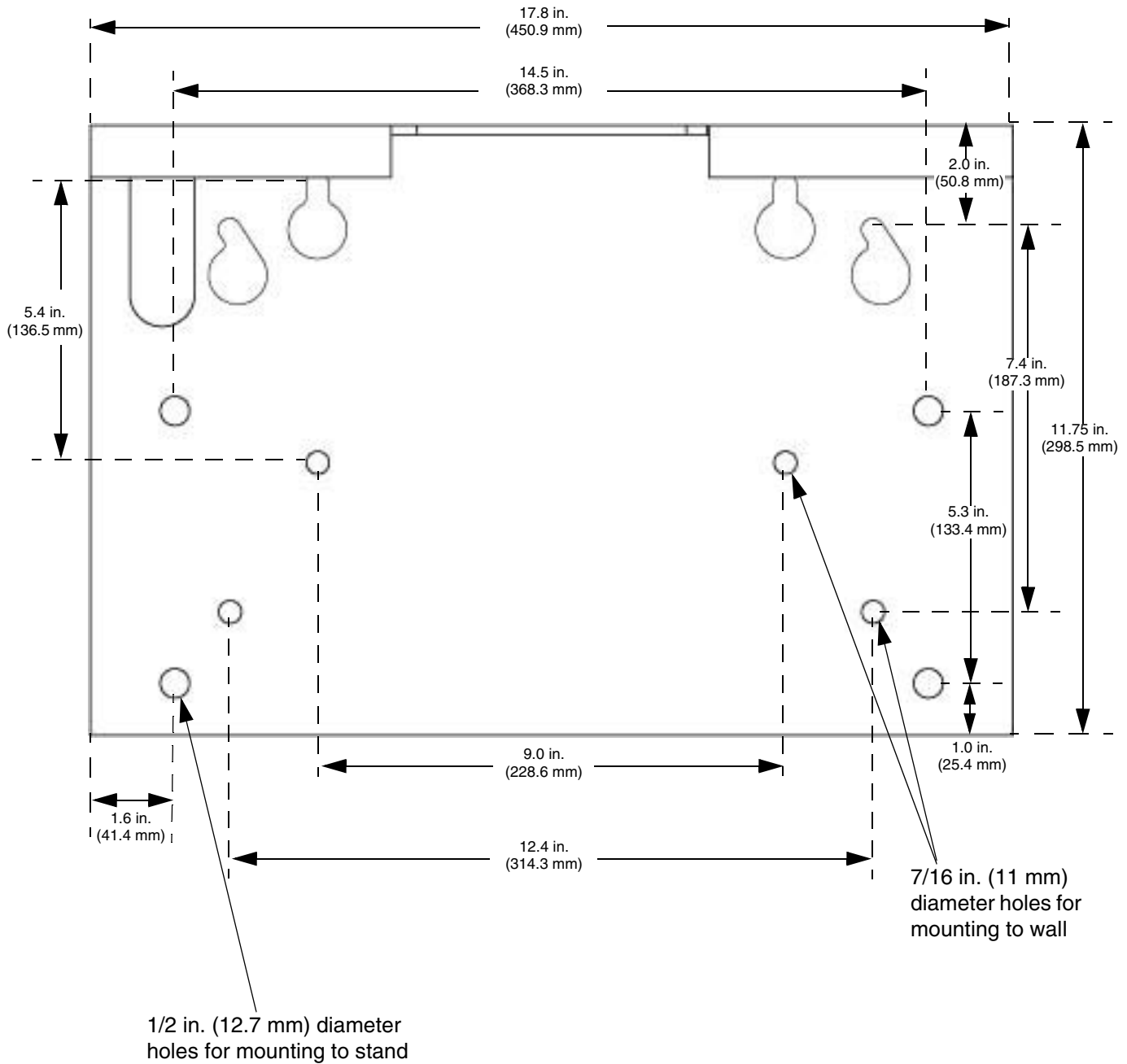

TI8614B

Dimensions

Wall Mount Packages
(247550, 247552, 247554)

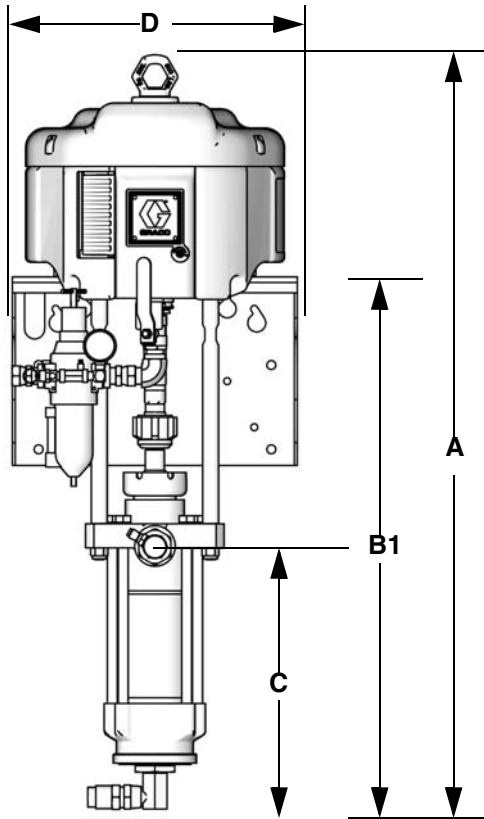

T111378b

Cart Mount Packages
(247549, 247551, 247553)

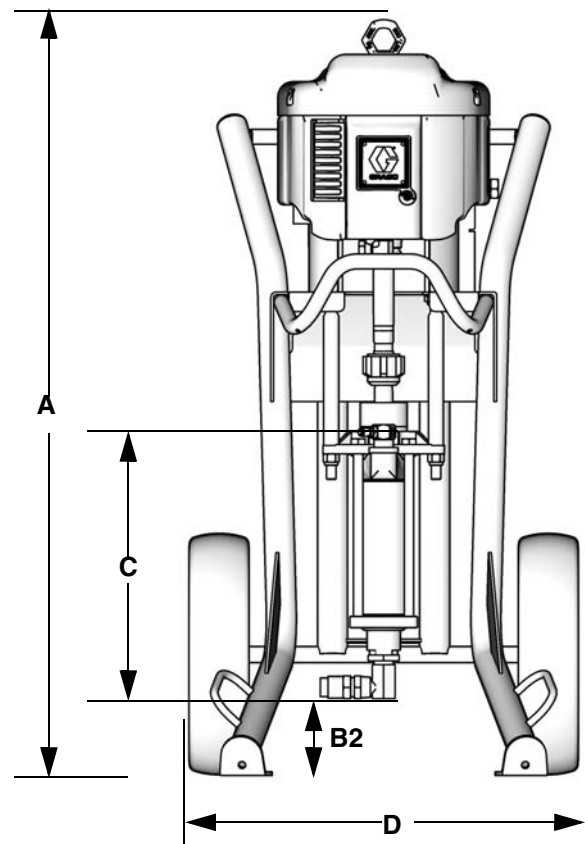

T111379b

Package	A in. (mm)	B1 in. (mm)	B2 in. (mm)	C in. (mm)	D in. (mm)	Air Inlet (in.)	Pump Fluid Inlet (in.)	Pump Fluid Outlet (in.)	Weight lb (kg)
247549	50.0 (1270)		5.6 (142)	17.1 (434)	25.7 (653)	3/4 npt(f)	1-1/2 in. npt(f)	1 in. npt(f)	308 (140)
247550	44.3 (1125)	30.8 (782)		17.1 (434)	17.8 (451)	3/4 npt(f)	1-1/2 in. npt(f)	1 in. npt(f)	227 (103)
247551	50.5 (1283)		3.9 (99)	15.9 (404)	25.7 (653)	3/4 npt(f)	2 in. npt(f)	1-1/2 in. npt(f)	368 (167)
247552	46.4 (1179)	32.5 (826)		15.9 (404)	17.8 (451)	3/4 npt(f)	2 in. npt(f)	1-1/2 in. npt(f)	289 (131)
247553	50.5 (1283)		4.3 (109)	15.9 (404)	25.7 (653)	3/4 npt(f)	2 in. npt(f)	1-1/2 in. npt(f)	365 (166)
247554	46.4 (1179)	32.5 (826)		15.9 (404)	17.8 (451)	3/4 npt(f)	2 in. npt(f)	1-1/2 in. npt(f)	284 (129)
258664	50.5 (1283)		5.2 (132)	14.7 (373)	25.7 (653)	3/4 npt(f)	2 in. npt(f)	1 in. npt(f)	357 (162)
258665	46.4 (1179)	32.5 (826)		14.7 (373)	17.8 (451)	3/4 npt(f)	2 in. npt(f)	1 in. npt(f)	278 (126)

Pump Performance Tables

12:1 Ratio Pumps (247549, 247550)

Fan Angle (°)	Spray Tip Orifice Size	40 PSI (0.3 MPa, 3 bar) Air Supply			70 PSI (0.5 MPa, 5 bar) Air Supply			100 PSI (0.7 MPa, 7bar) Air Supply		
		gpm (l/min)	cfm (m³/min)	Working Pressure in PSI (MPa, bar)	gpm (l/min)	cfm (m³/min)	Working Pressure in PSI (MPa, bar)	gpm (l/min)	cfm (m³/min)	Working Pressure in PSI (MPa, bar)
40	.030 (0.76)	1.00 (3.79)	7.86 (0.22)	450.90 (3.11,31.09)	1.33 (5.03)	16.50 (0.47)	808.68 (5.58, 55.76)	1.56 (5.91)	26.73 (0.76)	1144.56 (7.89, 78.91)
25	.045 (1.14)	1.48 (5.60)	11.32 (0.32)	450.85 (3.11, 31.09)	1.96 (7.42)	23.12 (0.65)	799.81 (5.51, 55.14)	2.33 (8.82)	38.46 (1.09)	1131.36 (7.80, 78.00)
40	.065 (1.65)	2.06 (7.80)	15.61 (0.44)	442.42 (3.05,30.50)	2.73 (10.33)	32.59 (0.92)	786.54 (5.42,54.23)	3.21 (12.15)	51.15 (1.45)	1111.41 (7.66, 76.63)
00	.080 (2.03)	2.49 (9.43)	18.84 (0.53)	449.22 (3.10, 30.97)	3.24 (12.26)	37.98 (1.07)	780.26 (5.38, 53.80)	3.79 (14.35)	60.29 (1.71)	1080.19 (7.45, 74.48)
15	.090 (2.29)	2.89 (10.94)	22.77 (0.64)	434.62 (3.00, 29.97)	3.54 (13.40)	40.51 (1.15)	770.16 (5.31, 53.10)	4.15 (15.71)	65.06 (1.84)	1079.40 (7.44, 74.42)

23:1 Ratio Pumps (247551, 247552)

Fan Angle (°)	Spray Tip Orifice Size	40 PSI (0.3 MPa, 3 bar) Air Supply			70 PSI (0.5 MPa, 5 bar) Air Supply			100 PSI (0.7 MPa, 7bar) Air Supply		
		gpm (l/min)	cfm (m³/min)	Working Pressure in PSI (MPa, bar)	gpm (l/min)	cfm (m³/min)	Working Pressure in PSI (MPa, bar)	gpm (l/min)	cfm (m³/min)	Working Pressure in PSI (MPa, bar)
40	.030 (0.76)	1.36 (5.15)	17.99 (0.51)	817.94 (5.64, 56.39)	1.79 (6.78)	37.16 (1.05)	1443.83 (9.95, 99.55)	2.08 (7.87)	57.34 (1.62)	2023.76 (13.95, 149.33)
25	.045 (1.14)	1.97 (7.46)	26.14 (0.74)	800.94 (5.52, 55.22)	2.58 (9.77)	51.62 (1.46)	1380.41 (9.52, 95.18)	2.99 (11.32)	80.34 (2.27)	1896.54 (13.08, 130.76)
40	.065 (1.65)	2.72 (10.30)	34.54 (0.98)	782.76 (5.40, 53.97)	3.41 (12.91)	67.09 (1.90)	1297.65 (8.95, 89.47)	3.91 (14.80)	103.85 (2.94)	1748.72 (12.06, 120.57)
00	.080 (2.03)	3.11 (11.77)	40.19 (0.44)	738.16 (3.05, 30.50)	4.01 (10.33)	78.96 (0.92)	1218.27 (5.42, 54.23)	4.54 (12.15)	119.29 (1.45)	1638.03 (7.66, 76.63)
15	.090 (2.29)	3.41 (12.91)	43.96 (1.24)	727.05 (5.01, 50.13)	4.17(15.79)	84.47 (2.39)	1179.52 (8.13, 81.33)	4.92 (18.62)	127.22 (3.60)	1589.38 (10.96, 109.58)

30:1 Ratio Pumps (247553, 247554)

Fan Angle (°)	Spray Tip Orifice Size	40 PSI (0.3 MPa, 3 bar) Air Supply			70 PSI (0.5 MPa, 5 bar) Air Supply			100 PSI (0.7 MPa, 7bar) Air Supply		
		gpm (l/min)	cfm (m³/min)	Working Pressure in PSI (MPa, bar)	gpm (l/min)	cfm (m³/min)	Working Pressure in PSI (MPa, bar)	gpm (l/min)	cfm (m³/min)	Working Pressure in PSI (MPa, bar)
40	.030 (0.76)	1.57 (5.94)	27.19 (0.77)	1066.61 (7.35, 73.54)	2.01 (7.61)	53.66 (1.52)	1852.60 (12.77, 127.73)	2.34 (8.86)	84.09 (2.38)	2544.63 (17.54, 175.45)
25	.045 (1.14)	2.21 (8.37)	38.94 (1.10)	1032.02 (7.12, 71.16)	2.84 (10.75)	74.49 (2.11)	1706.47 (11.77, 117.66)	3.27 (12.38)	113.18 (3.20)	2288.40 (15.78, 157.78)
40	.065 (1.65)	2.75 (10.41)	48.08 (1.36)	918.41 (6.33,63.32)	3.63 (13.74)	93.86 (2.66)	1531.03 (10.56, 105.56)	4.14 (15.67)	141.14 (3.99)	2023.48 (13.95, 139.51)
00	.080 (2.03)	3.34 (12.64)	58.01 (1.64)	878.21 (6.06, 60.55)	4.20 (15.90)	106.60 (3.02)	1372.78 (9.46, 94.65)	4.75 (17.98)	156.28 (4.42)	1798.13 (12.40, 123.98)
15	.090 (2.29)	3.70 (14.01)	58.36 (1.65)	861.09 (5.94, 59.37)	4.47 (16.92)	107.31 (3.04)	1321.22 (9.11, 91.09)	5.03 (19.04)	161.95 (4.58)	1730.06 (11.93, 119.28)

40:1 Ratio Pumps (258664, 258665)

Fan Angle (°)	Spray Tip Orifice Size	40 PSI (0.3 MPa, 3 bar) Air Supply			70 PSI (0.5 MPa, 5 bar) Air Supply			100 PSI (0.7 MPa, 7bar) Air Supply		
		gpm (l/min)	cfm (m³/min)	Working Pressure in PSI (MPa, bar)	gpm (l/min)	cfm (m³/min)	Working Pressure in PSI (MPa, bar)	gpm (l/min)	cfm (m³/min)	Working Pressure in PSI (MPa, bar)
40	.030 (0.76)	1.85 (7.00)	43.73 (1.24)	1497.12 (10.32, 103.22)	2.32 (8.78)	84.95 (2.40)	2457.17 (16.94, 169.42)	2.67 (10.11)	129.09 (3.65)	3297.10 (22.73, 227.33)
25	.045 (1.14)	2.44 (9.24)	58.22 (1.65)	1268.15 (8.74, 87.44)	3.11 (11.77)	109.99 (3.11)	2051.13 (14.14, 141.42)	3.46 (13.10)	160.80 (4.55)	2667.73 (18.39, 183.93)
40	.065 (1.65)	3.19 (12.08)	72.12 (2.04)	1124.94 (7.76, 77.56)	3.76 (14.23)	127.27 (3.60)	1661.93 (11.46, 114.59)	4.12 (15.60)	183.28 (5.19)	2140.70 (14.76, 147.56)
15	.090 (2.29)	3.65 (13.82)	79.74 (2.26)	907.49 (6.26, 62.57)	4.35 (16.47)	140.59 (3.98)	1364.81 (9.41, 94.10)	4.71 (17.83)	200.77 (5.68)	1757.38 (12.12, 121.17)

NOTE: Pumps are shipped with orifice tip sizes .030, .045, .065, .080 (this size not included with 40:1 models), and .090. Tips are available separately with orifices in .005 increments from .020 in. to .100 in.

Technical Data

Maximum fluid working pressure	
Part Nos. 247549 and 247550	1250 psi (8.6 MPa, 86.2 bar)
Part Nos. 247551 and 247552	2275 psi (15.7 MPa, 156.9 bar)
Part Nos. 247553 and 247554	3065 psi (21.1 MPa, 211.3 bar)
Part Nos. 258664 and 258665	4000 psi (27.6 MPa, 275.8 bar)
Maximum air working pressure.	100 psi (0.7 MPa, 7.0 bar)
Ratio	
Part Nos. 247549 and 247550	12:1
Part Nos. 247551 and 247552	23:1
Part Nos. 247553 and 247554	30:1
Part Nos. 258664 and 258665	40:1
Fluid Flow at 60 cpm	See Pump Performance Tables
Displacement pump size (cc per cycle)	
Part Nos. 247549 and 247550	550
Part Nos. 247551 and 247552	580
Part Nos. 247553 and 247554	430
Part Nos. 258664 and 258665	290
Maximum operating temperature	180°F (82°C)
Sound pressure	NXT air motors: See manual 311238, supplied.
Sound power	NXT air motors: See manual 311238, supplied.
Wetted parts	Displacement Pump: see manual 311825, 311827, or 312745 Spray Gun: see manual 308511 Hoses and Fittings: stainless steel, brass, nylon

Graco Standard Warranty

Graco warrants all equipment referenced in this document which is manufactured by Graco and bearing its name to be free from defects in material and workmanship on the date of sale to the original purchaser for use. With the exception of any special, extended, or limited warranty published by Graco, Graco will, for a period of twelve months from the date of sale, repair or replace any part of the equipment determined by Graco to be defective. This warranty applies only when the equipment is installed, operated and maintained in accordance with Graco's written recommendations.

This warranty does not cover, and Graco shall not be liable for general wear and tear, or any malfunction, damage or wear caused by faulty installation, misapplication, abrasion, corrosion, inadequate or improper maintenance, negligence, accident, tampering, or substitution of non-Graco component parts. Nor shall Graco be liable for malfunction, damage or wear caused by the incompatibility of Graco equipment with structures, accessories, equipment or materials not supplied by Graco, or the improper design, manufacture, installation, operation or maintenance of structures, accessories, equipment or materials not supplied by Graco.

This warranty is conditioned upon the prepaid return of the equipment claimed to be defective to an authorized Graco distributor for verification of the claimed defect. If the claimed defect is verified, Graco will repair or replace free of charge any defective parts. The equipment will be returned to the original purchaser transportation prepaid. If inspection of the equipment does not disclose any defect in material or workmanship, repairs will be made at a reasonable charge, which charges may include the costs of parts, labor, and transportation.

THIS WARRANTY IS EXCLUSIVE, AND IS IN LIEU OF ANY OTHER WARRANTIES, EXPRESS OR IMPLIED, INCLUDING BUT NOT LIMITED TO WARRANTY OF MERCHANTABILITY OR WARRANTY OF FITNESS FOR A PARTICULAR PURPOSE.

Graco's sole obligation and buyer's sole remedy for any breach of warranty shall be as set forth above. The buyer agrees that no other remedy (including, but not limited to, incidental or consequential damages for lost profits, lost sales, injury to person or property, or any other incidental or consequential loss) shall be available. Any action for breach of warranty must be brought within two (2) years of the date of sale.

GRACO MAKES NO WARRANTY, AND DISCLAIMS ALL IMPLIED WARRANTIES OF MERCHANTABILITY AND FITNESS FOR A PARTICULAR PURPOSE, IN CONNECTION WITH ACCESSORIES, EQUIPMENT, MATERIALS OR COMPONENTS SOLD BUT NOT MANUFACTURED BY GRACO. These items sold, but not manufactured by Graco (such as electric motors, switches, hose, etc.), are subject to the warranty, if any, of their manufacturer. Graco will provide purchaser with reasonable assistance in making any claim for breach of these warranties.

In no event will Graco be liable for indirect, incidental, special or consequential damages resulting from Graco supplying equipment hereunder, or the furnishing, performance, or use of any products or other goods sold hereto, whether due to a breach of contract, breach of warranty, the negligence of Graco, or otherwise.

FOR GRACO CANADA CUSTOMERS

The Parties acknowledge that they have required that the present document, as well as all documents, notices and legal proceedings entered into, given or instituted pursuant hereto or relating directly or indirectly hereto, be drawn up in English. Les parties reconnaissent avoir convenu que la rédaction du présente document sera en Anglais, ainsi que tous documents, avis et procédures judiciaires exécutés, donnés ou intentés, à la suite de ou en rapport, directement ou indirectement, avec les procédures concernées.

Graco Information

For the latest information about Graco products, visit www.graco.com.

For patent information, see www.graco.com/patents.

TO PLACE AN ORDER, contact your Graco distributor or call to identify the nearest distributor.

Phone: 612-623-6921 **or Toll Free:** 1-800-328-0211 **Fax:** 612-378-3505

*All written and visual data contained in this document reflects the latest product information available at the time of publication.
Graco reserves the right to make changes at any time without notice.*

Original instructions. This manual contains English. MM 312585

Graco Headquarters: Minneapolis

International Offices: Belgium, China, Japan, Korea

GRACO INC. P.O. BOX 1441 MINNEAPOLIS, MN 55440-1441

Copyright 2008, Graco Inc. All Graco manufacturing locations are registered to ISO 9001.

www.graco.com

Revision G, October 2014