



Husky™ 2150e Electric-Operated Diaphragm Pump

3A5131C
EN

2-Inch pumps with electric drive for fluid transfer applications.
Not approved for use in explosive atmospheres or hazardous locations unless otherwise stated. See Approvals page for more information. For professional use only.



Important Safety Instructions

Read all warnings and instructions in this manual and in your Husky 2150e Operation manual. **Save these instructions.**

*Maximum working pressure: 100 psi
(0.69 MPa, 6.9 bar)*

See page 7 for approvals.

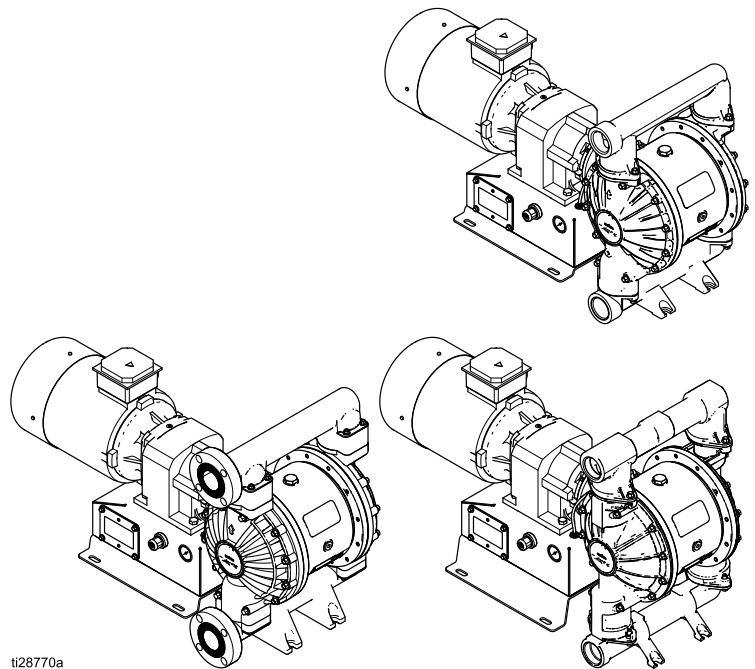

Contents





Related Manuals	2	Center Section Repair	15
Warnings	3	Leak Sensor Repair	20
Configuration Number Matrix	6	Replace the Compressor	21
Ordering Information	8	Torque Instructions	22
Troubleshooting	9	Torque sequence	22
Repair	11	Parts	24
Pressure Relief Procedure	11	Kits and Accessories	34
Check Valve Repair	11	Technical Data	35
Diaphragm Repair	13		







Related Manuals







Manual Number	Title
3A4068	Husky™ 2150e Electric-Operated Diaphragm Pump, Operation

Warnings

The following warnings are for the setup, use, grounding, maintenance, and repair of this equipment. The exclamation point symbol alerts you to a general warning and the hazard symbols refer to procedure-specific risks. When these symbols appear in the body of this manual or on warning labels, refer back to these Warnings. Product-specific hazard symbols and warnings not covered in this section may appear throughout the body of this manual where applicable.

 <h1 style="margin: 0;">WARNING</h1>	
 	<p>ELECTRIC SHOCK HAZARD</p> <p>This equipment must be grounded. Improper grounding, setup, or usage of the system can cause electric shock.</p> <ul style="list-style-type: none"> • Turn off and remove power before disconnecting any cables and before servicing or installing equipment. For cart-mounted models, unplug the power cord. For all other units, disconnect power at the main switch. • Connect only to grounded power source. • All electrical wiring must be done by a qualified electrician and comply with all local codes and regulations. • Wait five minutes for capacitor discharge before opening equipment.
    	<p>FIRE AND EXPLOSION HAZARD</p> <p>Flammable fumes, such as solvent and paint fumes, in work area can ignite or explode. Paint or solvent flowing through the equipment can cause static sparking. To help prevent fire and explosion:</p> <ul style="list-style-type: none"> • Use equipment only in well ventilated area. • Eliminate all ignition sources; such as pilot lights, cigarettes, portable electric lamps, and plastic drop cloths (potential static arc). • Ground all equipment in the work area. See Grounding instructions. • Keep work area free of debris, including solvent, rags and gasoline. • Do not plug or unplug power cords, or turn power or light switches on or off when flammable fumes are present. • Use only grounded hoses. • Stop operation immediately if static sparking occurs or you feel a shock. Do not use equipment until you identify and correct the problem. • Keep a working fire extinguisher in the work area. <p>Static charge may build up on plastic parts during cleaning and could discharge and ignite flammable vapors. To help prevent fire and explosion:</p> <ul style="list-style-type: none"> • Clean plastic parts only in well ventilated area. • Do not clean with a dry cloth. • Do not operate electrostatic guns in equipment work area.

 <h1 style="margin: 0;">WARNING</h1>	
  	<p>PRESSURIZED EQUIPMENT HAZARD</p> <p>Fluid from the equipment, leaks, or ruptured components can splash in the eyes or on skin and cause serious injury.</p> <ul style="list-style-type: none"> Follow the Pressure Relief Procedure when you stop spraying/dispensing and before cleaning, checking, or servicing equipment. Tighten all fluid connections before operating the equipment. Check hoses, tubes, and couplings daily. Replace worn or damaged parts immediately.
 	<p>EQUIPMENT MISUSE HAZARD</p> <p>Misuse can cause death or serious injury.</p> <ul style="list-style-type: none"> Do not operate the unit when fatigued or under the influence of drugs or alcohol. Do not exceed the maximum working pressure or temperature rating of the lowest rated system component. See Technical Data in all equipment manuals. Use fluids and solvents that are compatible with equipment wetted parts. See Technical Data in all equipment manuals. Read fluid and solvent manufacturer's warnings. For complete information about your material, request Safety Data Sheet (SDS) from distributor or retailer. Turn off all equipment and follow the Pressure Relief Procedure when equipment is not in use. Check equipment daily. Repair or replace worn or damaged parts immediately with genuine manufacturer's replacement parts only. Do not alter or modify equipment. Alterations or modifications may void agency approvals and create safety hazards. Make sure all equipment is rated and approved for the environment in which you are using it. Use equipment only for its intended purpose. Call your distributor for information. Route hoses and cables away from traffic areas, sharp edges, moving parts, and hot surfaces. Do not kink or over bend hoses or use hoses to pull equipment. Keep children and animals away from work area. Comply with all applicable safety regulations.
	<p>PRESSURIZED ALUMINUM PARTS HAZARD</p> <p>Use of fluids that are incompatible with aluminum in pressurized equipment can cause serious chemical reaction and equipment rupture. Failure to follow this warning can result in death, serious injury, or property damage.</p> <ul style="list-style-type: none"> Do not use 1,1,1-trichloroethane, methylene chloride, other halogenated hydrocarbon solvents or fluids containing such solvents. Do not use chlorine bleach. Many other fluids may contain chemicals that can react with aluminum. Contact your material supplier for compatibility.

 <h1 style="margin: 0;">WARNING</h1>	
	<p>THERMAL EXPANSION HAZARD</p> <p>Fluids subjected to heat in confined spaces, including hoses, can create a rapid rise in pressure due to the thermal expansion. Over-pressurization can result in equipment rupture and serious injury.</p> <ul style="list-style-type: none"> • Open a valve to relieve the fluid expansion during heating. • Replace hoses proactively at regular intervals based on your operating conditions.
	<p>PLASTIC PARTS CLEANING SOLVENT HAZARD</p> <p>Many solvents can degrade plastic parts and cause them to fail, which could cause serious injury or property damage.</p> <ul style="list-style-type: none"> • Use only compatible water-based solvents to clean plastic structural or pressure-containing parts. • See Technical Data in this and all other equipment instruction manuals. Read fluid and solvent manufacturer's Safety Data Sheet (SDS) and recommendations.
	<p>TOXIC FLUID OR FUMES HAZARD</p> <p>Toxic fluids or fumes can cause serious injury or death if splashed in the eyes or on skin, inhaled, or swallowed.</p> <ul style="list-style-type: none"> • Read Safety Data Sheet (SDS) to know the specific hazards of the fluids you are using. • Store hazardous fluid in approved containers, and dispose of it according to applicable guidelines.
	<p>BURN HAZARD</p> <p>Equipment surfaces and fluid that's heated can become very hot during operation. To avoid severe burns:</p> <ul style="list-style-type: none"> • Do not touch hot fluid or equipment.
	<p>PERSONAL PROTECTIVE EQUIPMENT</p> <p>Wear appropriate protective equipment when in the work area to help prevent serious injury, including eye injury, hearing loss, inhalation of toxic fumes, and burns. This protective equipment includes but is not limited to:</p> <ul style="list-style-type: none"> • Protective eyewear, and hearing protection. • Respirators, protective clothing, and gloves as recommended by the fluid and solvent manufacturer.

Configuration Number Matrix

Check the identification plate (ID) for the Configuration Number of your pump. Use the following matrix to define the components of your pump.

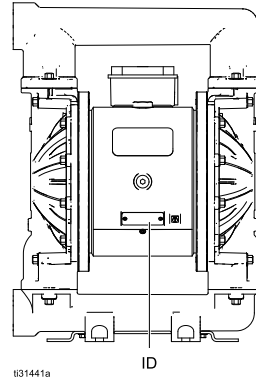





Sample Configuration Number: **2150A-E,A04AA1TPTPTP- -**

2150	A	E	A	04	A	A1	TP	TP	TP	- -
Pump Model	Wetted Section Material	Drive	Center Section Material	Gear Box and Compressor	Motor	Fluid Covers and Manifolds	Seats	Balls	Diaphragms	Manifold O-Rings

NOTE: Some combinations are not possible. Please refer to [Ordering Information, page 8](#) .

Pump	Wetted Section Material		Drive Type		Center Section Material		Gearbox and Compressor		Motor	
	2150	A	Aluminum	E	Electric	A	Aluminum	94	No Gearbox or Compressor	A
	C	Conductive Polypropylene			S	Stainless Steel	04	High Speed Gear Ratio	C	ATEX Induction Motor
	F	PVDF			05		High Speed Gear Ratio/120V Compressor	D	Flameproof Induction Motor	
	I	Cast Iron			06		High Speed Gear Ratio/240V Compressor	G	No Motor	
	P	Polypropylene			14		Mid Speed Gear Ratio			
	S	Stainless Steel			15		Mid Speed Gear Ratio/120V Compressor			
					16		Mid Speed Gear Ratio/240V Compressor			
					24		Low Speed Gear Ratio			
					25		Low Speed Gear Ratio/120V Compressor			
					26		Low Speed Gear Ratio/240V Compressor			

Fluid Covers and Manifolds		Seat Material		Ball Material		Diaphragm Material		Manifold O-Rings	
A1	Aluminum, npt	GE	Geolast	AC	Acetal	GE	Geolast	--	Model does not use o-rings
A2	Aluminum, bsp	PP	Polypropylene	CW	Polychloroprene Weighted	PT	PTFE/EPDM 2-Piece	PT	PTFE
C2	Conductive polypropylene, end flange	PV	PVDF	GE	Geolast	SP	Santoprene		
F2	PVDF, end flange	SP	Santoprene	PT	PTFE	TP	TPE		
P2	Polypropylene, end flange	SS	316 Stainless Steel	SD	440C Stainless Steel				
S1	Stainless steel, npt	TP	TPE	SP	Santoprene				
S2	Stainless steel, bsp			TP	TPE				
S5-1	Stainless steel, center flange, horizontal outlet								
S5-2	Stainless steel, center flange, vertical outlet								
I1	Cast Iron, standard ports, npt								
I2	Cast Iron, standard ports, bsp								

Approvals	
<p>◆ Aluminum, cast iron, conductive polypropylene, and stainless steel pumps with motor code C are certified to:</p>	 II 2 G Ex h d IIB T3 Gb
<p>✚ Aluminum, cast iron, conductive polypropylene, and stainless steel pumps with motor code G are certified to:</p>	 II 2 G Ex h IIB T3 Gb
<p>★ Motors coded D are certified to:</p>	 LISTED Class I, Div 1, Group D, T3B Class II, Div 1, Group F & G, T3B 
<p>All Models (except gearbox and compressor codes 05, 15, and 25, or motor code D) are certified to:</p>	

Ordering Information

To Find Your Nearest Distributor

1. Visit www.graco.com.
2. Click on **Where to Buy** and use the **Distributor Locator**.

To Specify the Configuration of a New Pump

Please call your distributor.

OR

Use the **Online Diaphragm Pump Selector Tool** at www.graco.com. Go to the **Process Equipment Page**.

To Order Replacement Parts

Please call your distributor.

Troubleshooting



- Follow the [Pressure Relief Procedure, page 11](#), before checking or servicing the equipment.
- Check all possible problems and causes before disassembly.

Problem	Cause	Solution
Pump cycles but will not prime and/or pump.	Pump is running too fast, causing cavitation before prime.	Slow down the controller (VFD)
	Center section has no air pressure, or air pressure is too low.	Apply air pressure to center section per your application requirements.
	Check valve ball is severely worn or wedged in seat or manifold.	Replace the ball and seat.
	The pump has insufficient suction pressure.	Increase the suction pressure. See the Operation manual.
	Seat is severely worn.	Replace the ball and seat.
	Outlet or inlet is restricted.	Remove the restriction.
	Inlet fittings or manifolds are loose.	Tighten.
	Manifold o-rings are damaged.	Replace o-rings.
The center section is excessively hot.	The drive shaft is broken.	Replace.
Pump fails to hold fluid pressure at stall.	Check valve balls, seats, or o-rings are worn.	Replace.
	Manifold screws or fluid cover screws are loose.	Tighten.
	Diaphragm shaft bolt is loose	Tighten.
Pump will not cycle.	Motor or controller is wired improperly.	Wire per manual.
	The leak detector (if installed) has tripped.	Check diaphragm for rupture or incorrect installation. Repair or replace.
The motor is operating, but the pump will not cycle.	The jaw coupling between the motor and gearbox is not connected properly.	Check the connection.
Pump flow rate is erratic.	Suction line is clogged.	Inspect; clear.
	Check balls are sticky or leaking .	Clean or replace.
	Diaphragm (or backup) ruptured.	Replace.
Pump makes unusual noises.	Pump is operating near or at stall pressure.	Adjust air pressure or slow the pump speed.

Troubleshooting

Problem	Cause	Solution
Air consumption is higher than expected.	A fitting is loose.	Tighten. Inspect thread sealant.
	Loose or damaged o-rings or shaft seal.	Replace.
	Diaphragm (or backup) ruptured.	Replace.
Air bubbles in fluid.	Suction line is loose.	Tighten.
	Diaphragm (or backup) ruptured.	Replace.
	Loose manifolds, damaged seats or o-rings.	Tighten manifold bolts or replace seats or o-rings.
	Loose diaphragm shaft bolt.	Tighten.
Pump leaks fluid externally from joints.	Loose manifold screws or fluid cover screws.	Tighten.
	Manifold o-rings worn out.	Replace o-rings.
The controller faults or shuts down.	A GFCI has tripped.	Remove the controller from the GFCI circuit.
	Supply power is poor.	Determine and fix the source of the power problem.
	Operational parameters are exceeded.	See performance chart; ensure pump is operating within the continuous duty range.
Excessive motor regeneration fault from VFD	Inlet check clogged/improperly installed	Remove debris/install properly
	Broken diaphragm bolt	Replace bolt
NOTE: For problems with a Variable Frequency Device (VFD), see your VFD manual.		

Repair

Pressure Relief Procedure



Follow the Pressure Relief Procedure whenever you see this symbol.

<p>This equipment stays pressurized until pressure is relieved manually. To help prevent serious injury from pressurized fluid, such as splashing in the eyes or on skin, follow the Pressure Relief Procedure when you stop pumping and before you clean, check, or service the equipment.</p>				

1. Remove power from the system.
2. Open the dispensing valve, if used.
3. Open the fluid drain valve to relieve fluid pressure. Have a container ready to catch the drainage.
4. Back out regulator knob to bleed any internal air pressure.

Check Valve Repair

--	--	--	--	--

Tools Required

- Torque wrench
- 10 mm socket wrench (plastic pumps)
- 13 mm socket wrench (metal pumps)
- O-ring pick

NOTE: Kits are available for new check valve balls and seats in a range of materials. O-ring and fastener kits also are available.

NOTE: To ensure proper seating of the check balls, always replace the seats when replacing the balls. Also, replace the o-rings every time the manifold is removed.

Disassemble the Check Valve

1. Follow the [Pressure Relief Procedure, page 11](#). Remove power from the motor. Disconnect all hoses.
2. **NOTE for plastic pumps:** Use hand tools until thread-locking adhesive patch releases.
3. Use a 10 mm (plastic pump) or 13 mm (metal pump) socket wrench to remove the manifold fasteners (5) and nuts (42; used only on stainless steel models), then remove the outlet manifold (3).
4. Remove the seats (6), balls (7), and o-rings (8) if present.
NOTE: Some models do not use o-rings (8).
5. Repeat for the inlet manifold (4), o-rings (8) if present, seats (6), and balls (7).

To continue disassembly, see [Disassemble the Diaphragms, page 13](#).

Reassemble the Check Valve

1. Clean all parts and inspect for wear or damage. Replace parts as needed.
2. Reassemble in the reverse order, following all notes in the illustration. Put the inlet manifold on first. Be sure the ball checks and manifolds are assembled **exactly** as shown. The arrows (A) on the fluid covers (2) **must** point toward the outlet manifold (3).

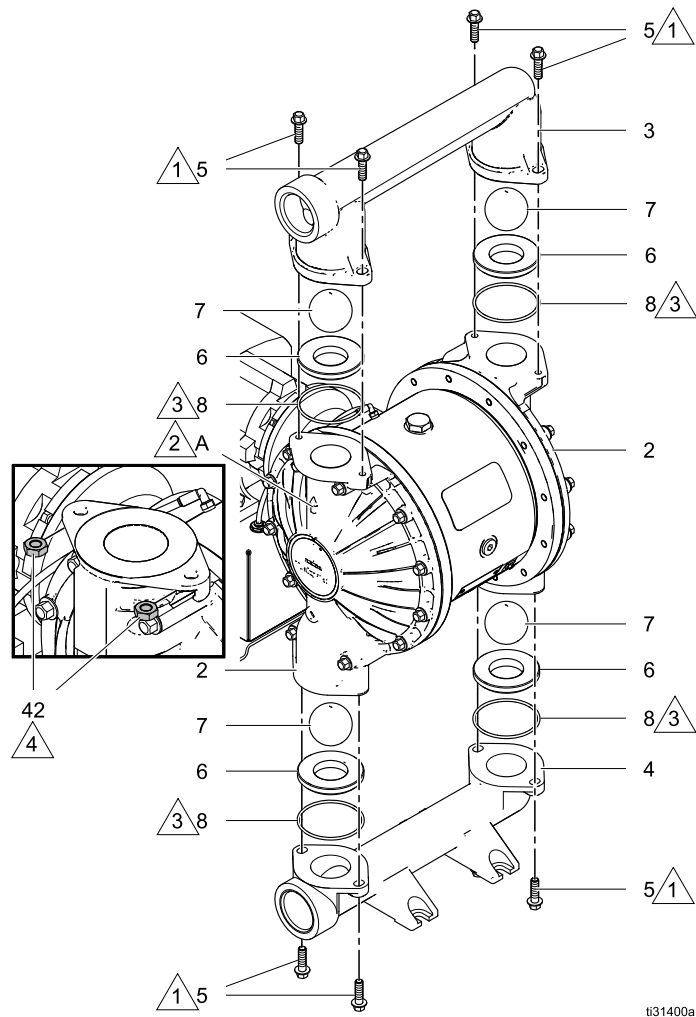

ti31400a

Check valve assembly, aluminum model shown



Apply medium-strength (blue) thread locker. Torque to the value specified for your pump. See [Torque Instructions, page 22](#).



Arrow (A) must point toward outlet manifold



Not used on some models.



Stainless steel models include nuts (42).

Diaphragm Repair

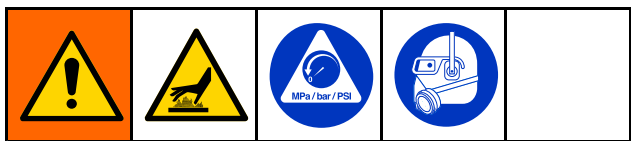

Disassemble the Diaphragms

NOTE: Diaphragm kits are available in a range of materials and styles. See Parts section.

1. Follow the [Pressure Relief Procedure, page 11](#). Remove power from the motor. Disconnect all hoses.
2. Remove the manifolds and disassemble the ball check valves as explained in [Check Valve Repair, page 11](#).
3. Use a 13 mm socket wrench to remove the bolts (5) from the fluid covers, then pull the fluid covers off of the pump.
4. To remove the diaphragms, the piston must be moved fully to one side. If the pump is not attached to the gearbox, turn the shaft by hand to move the piston. If the pump is still attached to the gearbox, loosen the screws and remove the fan cover. Turn the fan by hand to rotate the shaft to shift the piston to one side.

TIP: The air cover has 2 holes (H), one at the 9 o'clock position and another at the 3 o'clock position (shown below). Use pin (131), placed in either hole (H) as a brace for the wrench while removing or installing diaphragm bolts.

- a. **Metal Pumps:** Hold a 28 mm wrench on the wrench flats of the exposed piston shaft. Use another wrench (10 mm hex key) on the shaft bolt (13) to remove it. Then remove all parts of the diaphragm assembly.
Plastic Pumps: Hold a 28 mm wrench on the wrench flats of the exposed piston shaft. Use a 24 mm socket or box end wrench on the hex of the fluid side diaphragm plate to remove the cover. Then use a 10 mm hex key to remove the bolt.
- b. Rotate the drive shaft to move the piston fully to one side. See instructions in step 4. Repeat step a.

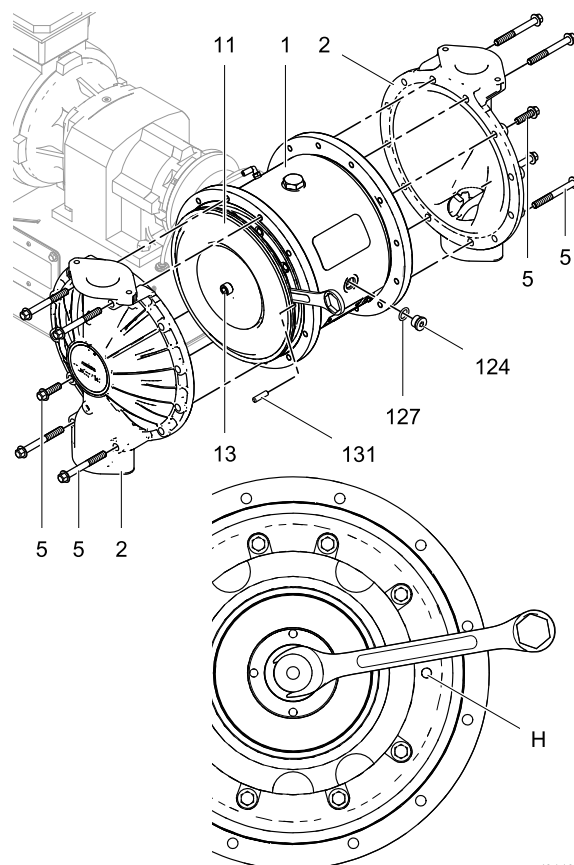

t31401a

5. To continue with disassembly, see [Disassemble the Center Section, page 15](#).

Reassemble the Diaphragms

Follow all notes in the illustrations on page 15. These notes contain **important** information.

NOTICE

After reassembly, allow the thread locker to cure for 12 hours, or per manufacturer's instructions, prior to operating the pump. Damage to the pump will occur if the diaphragm shaft bolt loosens.

TIP: If you are also repairing or servicing the center section (drive shaft, piston, etc.), see [Center Section Repair, page 15](#), before you put the diaphragms back on.

1. Clean all parts and inspect for wear or damage. Replace parts as needed. Be sure the center section is clean and dry.

2. All Other Diaphragms-Metal Pumps

- a. Thoroughly clean or replace the diaphragm bolt (13). Install the o-ring (34).
- b. Assemble the fluid side plate (9), the diaphragm (11), the backup diaphragm (12, if present), and the air side diaphragm plate (10) on the bolt exactly as shown.
- c. Clean the female threads of the piston shaft with a wire brush dipped in solvent to remove any residual thread locker. Apply thread-locking primer and allow it to dry.
- d. Apply medium-strength (blue) thread locker to the threads of the bolt.
- e. Hold a 28 mm wrench on the wrench flats of the piston shaft. Screw the bolt onto the shaft and torque to 100 ft-lb (135 N•m).
- f. Rotate the drive shaft to move the piston fully to one side. See instructions in step 4 of [Disassemble the Diaphragms, page 13](#).
- g. Repeat to install the other diaphragm assembly.

3. All Other Diaphragms-Plastic Pumps

- a. Thoroughly clean or replace the diaphragm bolt (13). Install the o-ring (34).
- b. Assemble the fluid side plate (9), the diaphragm (11), the backup diaphragm (12, if present), and the air side diaphragm plate (10) on the bolt exactly as shown.

- 1 Rounded side faces diaphragm.
- 2 Apply medium-strength (blue) thread locker to the threads.
- 3 AIR SIDE markings on diaphragm must face the center housing.
- 5 Torque to 100 ft-lb (135 N•m) at 100 rpm maximum.
- 6 Apply primer to the female threads. Allow to dry.

- c. Clean the female threads of the piston shaft with a wire brush dipped in solvent to remove any residual thread locker. Apply thread-locking primer and allow it to dry.
 - d. Apply medium-strength (blue) thread locker to the threads of the bolt.
 - e. Hold a 28 mm wrench on the wrench flats of the piston shaft. Screw the bolt onto the shaft and torque to 100 ft-lb (135 N•m).
 - f. Install an o-ring (13b) and plug (13a) on the fluid plate.
 - g. Rotate the drive shaft to move the piston fully to one side. See instructions in step 4 of [Disassemble the Diaphragms, page 13](#).
 - h. Repeat to install the other diaphragm assembly.
4. Attach the fluid covers. The arrow on each fluid cover must point toward the outlet manifold. Apply medium-strength (blue) thread locker to the bolt threads. See [Torque Instructions, page 22](#), to tighten.
 5. Reassemble the check valves and manifolds. See [Reassemble the Check Valve, page 11](#).
 6. Restore motor cooling fan cover and pin (131) to their original locations.

2-Piece (PT, TP, SP, and GE) Models

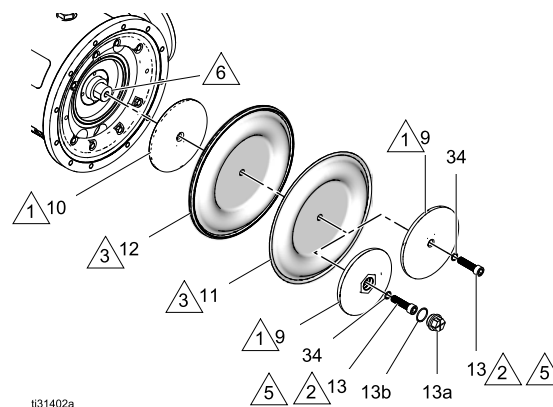

NOTICE

After reassembly, allow the thread locker to cure for 12 hours, or per manufacturer's instructions, prior to operating the pump. Damage to the pump will occur if the diaphragm shaft bolt loosens.

Center Section Repair

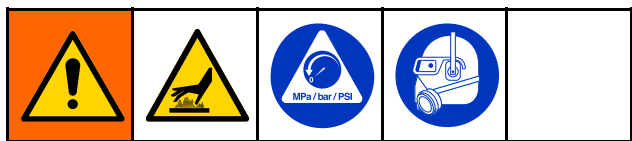

Disassemble the Center Section

See the illustrations on page 18.

1. Follow the [Pressure Relief Procedure, page 11](#). Remove power from the motor. Disconnect all hoses.
2. Remove the manifolds and check valve parts as directed in [Disassemble the Check Valve, page 11](#).
3. Remove the fluid covers and diaphragms as directed in [Disassemble the Diaphragms, page 13](#).
TIP: Clamp the gear box bracket (15) to the bench. Leave the pump connected to the motor.
4. Use a 10 mm hex wrench to remove 4 bolts (117). Pull the pump off the alignment housing (116).
TIP: It may be necessary to tap the pump with a rubber mallet to disengage the coupler.
5. Use a 5/16 hex wrench to remove the plug (124). Use a 30 mm socket wrench to remove the bearing bolt (106) and the o-ring (108) from the top.
6. Turn the shaft so the groove on the shaft is at the top, in line with the alignment markings.

7. Use a 3/4–16 bolt to push out the drive shaft assembly (112). You can also use the bearing bolt (106), but remove the bearing (107) first. Be sure that the groove on the drive shaft remains aligned with the markings in the center section.

NOTE: Remove the bolt after the drive shaft is freed.

NOTICE

Proper alignment is essential. Do not apply more than about 10 in-lb (1.1 N•m) of torque. Excessive torque could strip the housing thread. If you encounter resistance, check alignment or contact your distributor.

8. The shaft coupler (113) might come out with the drive shaft assembly. If not, remove from gearbox (118).
9. Remove the seal cartridge (110), the o-ring (109) and the radial seal (111) from the drive shaft assembly.
10. Slide the piston assembly (102) out of the center.
11. Only remove the alignment housing (116) if needed. Use a 10 mm hex wrench to remove 4 bolts (120). Pull the alignment housing off the gearbox (118).
12. Leave the gearbox coupler (114) attached to the gearbox shaft (118) unless it is damaged. If you need to remove it, a bearing puller must be used.

Reassemble the Center Section

1. Clean and dry the center housing (101), the center of the piston (102) and the drive shaft (112).
2. Inspect the piston and center section bearings for excessive wear and replace if needed. Grease the piston as shown and install it in the center section with the slot on the top, in line with the alignment markings in the center section.
3. Install the o-ring (108) and apply medium-strength (blue) thread locker to the bearing bolt (106) and screw into the center section. Be sure that the bearing (107) is in the slot on the piston, as shown. Be sure that the piston moves freely. Torque the bolt (106) to 15–25 ft-lb (20–34 N•m).

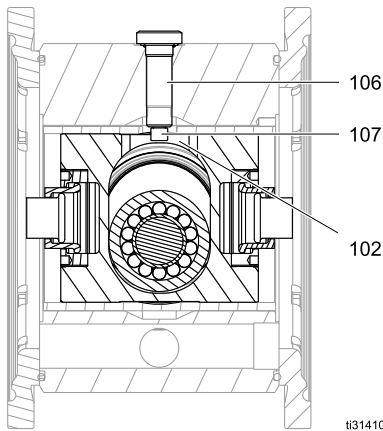

4. Be sure the sealing surface of the drive shaft (112) is clean. Install the seal cartridge (110) and the radial seal (111) on the drive shaft. The lips on the radial seal (111) must face **IN** toward the center. Inspect seal lip for damage. Replace if necessary.

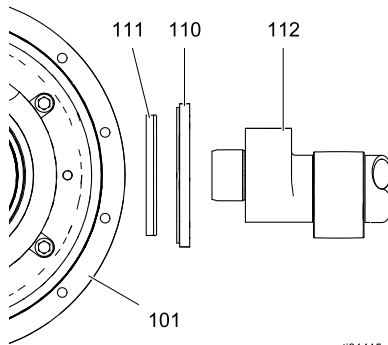

5. Install o-ring (109) to the center housing (101).
6. Apply anti-seize lubricant on the mating edges of the drive shaft, as shown in the illustration, page 18.
7. Center the piston in the housing and install the drive shaft assembly (112) into the center housing (101) with the groove facing up.
8. Inspect the shaft coupler (113) for wear and replace if needed. Install on the drive shaft.
9. If removed, install the alignment housing to the center section. Apply medium-strength (blue) thread locker and install the housing screws (117). Torque to 130–160 in-lb (15–18 N•m).
10. If removed, install the gearbox coupler (114) on the gearbox (118) shaft. Use an M12 x 30 bolt and a large washer inserted into the hole in the shaft to press the coupler into position. The coupler is in proper position when it is flush with the end of the shaft.
11. Be sure the gearbox coupler (114) is aligned properly. Turn by hand if needed. Connect the pump to the gearbox assembly, engaging the couplers.
12. Apply medium-strength (blue) thread locker and install the gearbox screws (120). Torque to 130–160 in-lb (15–18 N•m).
13. Be sure o-ring (127) is on the plug (124). Install the plug and torque to 15–25 ft-lb (20–34 N•m).
14. See [Reassemble the Diaphragms, page 13](#), and [Reassemble the Check Valve, page 11](#).

- 1 Apply medium-strength (blue) thread locker to threads.
- 2 Torque to 15–25 ft-lb (20–34 N•m).
- 3 Lips must face **IN** toward the center.
- 4 Apply anti-seize lubricant liberally on the radial surfaces of the drive shaft assembly.
- 5 Install the drive shaft assembly with the groove facing up.
- 6 Tighten screws in a crisscross pattern, 5 turns at a time, to engage the coupler evenly. Torque to 130–160 in-lb (15–18 N•m).
- 7 Apply lubricant to inner mating surface.

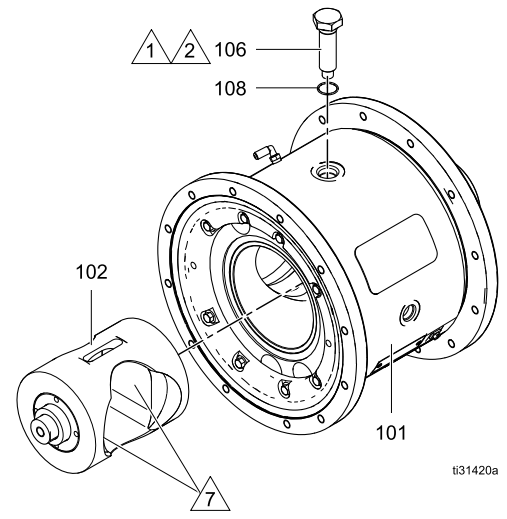

ti31420a

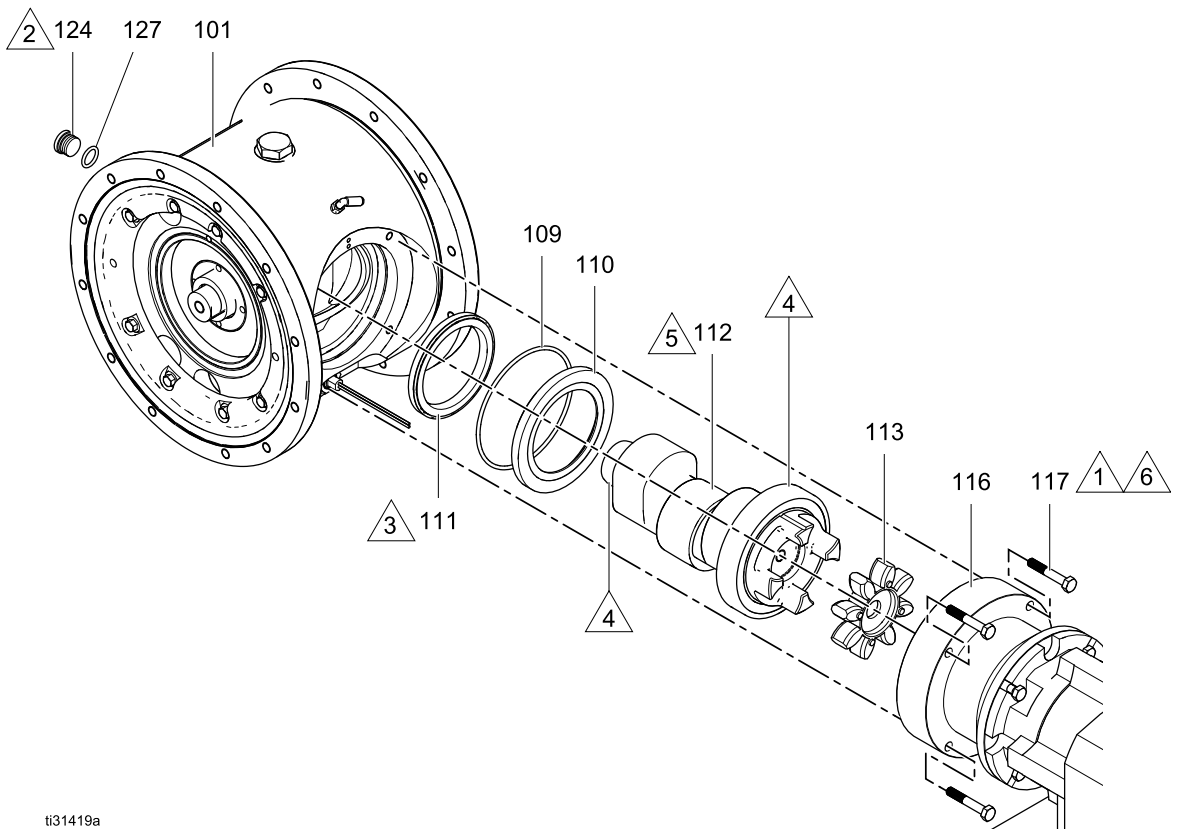

ti31419a

Replace Center Bearing

NOTE: Follow this procedure only if you suspect that the center bearing is damaged. You will need Center Section Repair Kit 25B433. You also will need Bearing Tool Kit 25B434 and bearing puller kit 17J718.

1. Follow all steps in [Disassemble the Center Section, page 15](#).
2. Use arbor press and tool to push out center sleeve.

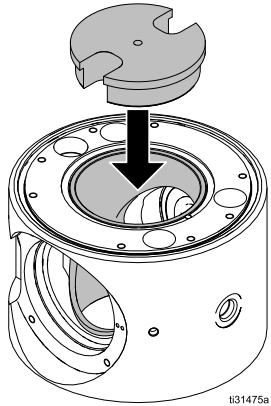

3. Place the center housing (101) in a vise with the bearing (D) side on the bottom.
4. Place the repair tool on the housing.
5. Use tool (A) and bearing puller (B) to remove the bearing (D).

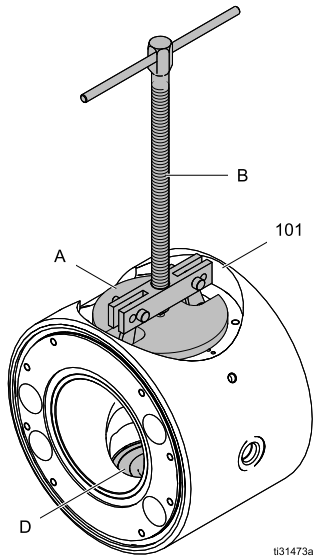

6. Use an arbor press to install the new bearing (D) into the center housing (101). Press the bearing to the shoulder in the center housing.

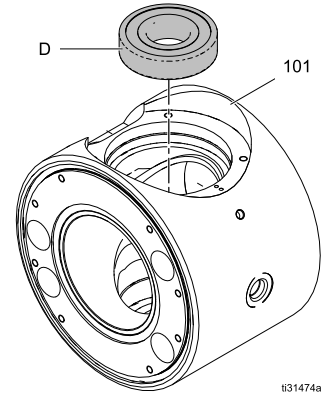

7. Use an arbor press and the press-fit tool and alignment ring to install the sleeve. Ensure that the groove on the sleeve aligns with the pin in the center housing, as shown below. Install the sleeve flush with the center housing.

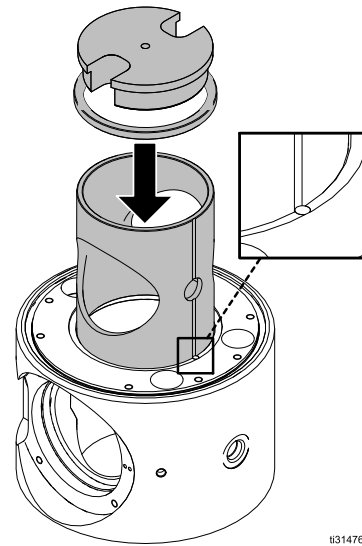

8. Follow all steps in [Reassemble the Center Section, page 16](#).

Disconnect the Motor and Gearbox

NOTE: Normally, the motor remains connected to the gearbox. Disconnect the motor only if you suspect that the motor or gearbox must be replaced.

TIP: Clamp the gearbox bracket (15) to the bench.

Start at step 1 for ATEX or Flameproof motors. Standard AC motors (04A, 05A, or 06A) are of one piece with the gearbox, so begin with step 3.

NOTE: Use a hoist and sling to remove motor weight from the gearbox during removal.

1. Use a 3/4 in. socket wrench to remove 4 screws (122).
2. Pull the motor (121) straight off of the gearbox (118).
3. Use a 3/4 in. socket wrench to remove 4 bolts (17) and nuts (18, if present). Lift the gear box off of the bracket. **NOTE:** If you have an AC motor with gearbox, lift the whole unit off of the bracket.

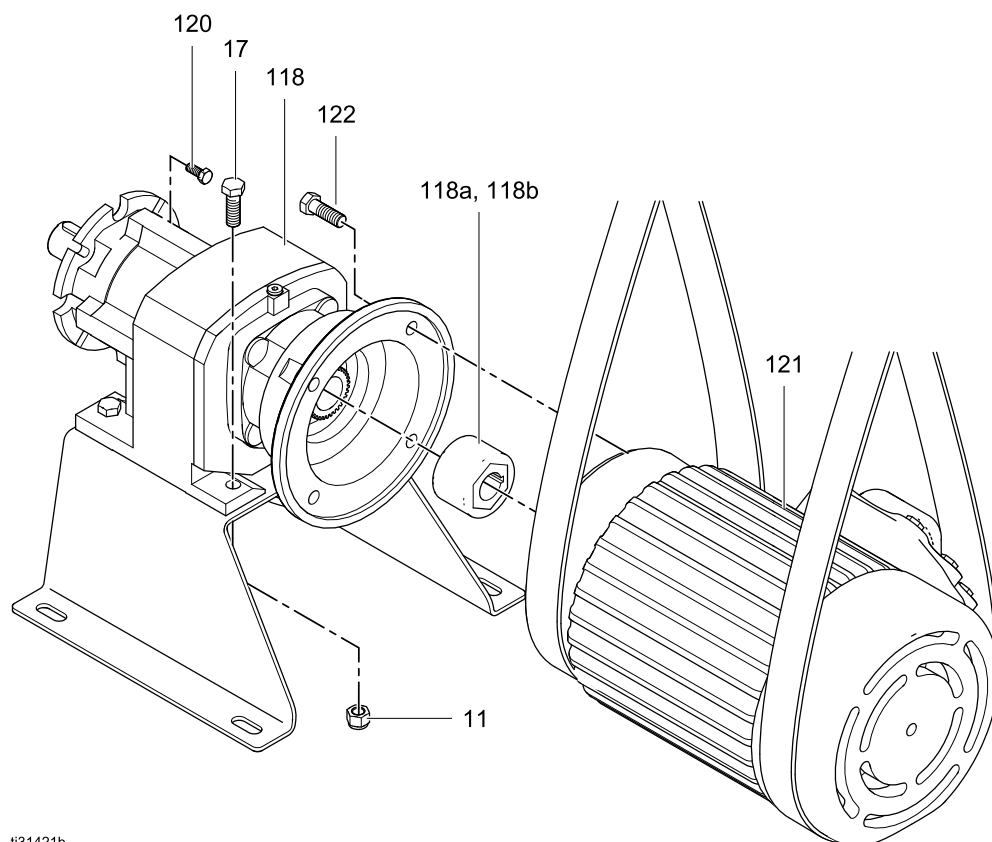

i31421b

Leak Sensor Repair

NOTE: A previous design of the leak sensor exists. If your leak sensor contains a jam nut, refer to manual 3A5131A for repair instructions.

The leak sensor can be replaced or re-positioned. When properly positioned, the two arrows imprinted on two of the flat surfaces of the leak sensor hex head are vertical and pointing down.

Leak Sensor Testing

Testing the continuity of the leak sensor is possible to ensure proper operation. If continuity testing indicates that the leak sensor is not functional, a replacement kit, 25B435, can be ordered separately.

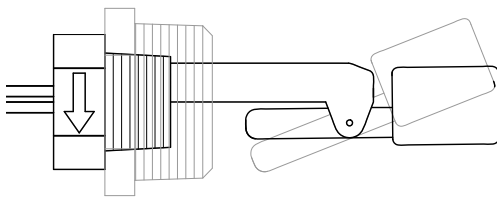

1. Follow the [Pressure Relief Procedure, page 11](#). Remove power from the motor.
2. To test the leak sensor without removing from the pump:
 - a. Note the connection locations of the leak sensor wires within the VFD or other monitoring device, then disconnect the leak sensor wires.
 - b. Use an ohmmeter attached to the leak sensor leads to test the conductivity of the leak sensor. Continuity is affirmed by a reading of 0-5 ohms.
 - c. Loosen the leak sensor bushing 1/2 turn (leak sensor arrows point up).
 - d. Use an ohmmeter attached to the leak sensor leads to test the conductivity of the leak sensor. An open circuit should be indicated.
3. Remove and replace the leak sensor at the pump:
 - a. Note the connection locations of the leak sensor wires within the VFD or other monitoring device, then disconnect the leak sensor wires.
 - b. Remove the leak sensor and bushing from the pump center section.
 - c. Apply thread tape or paste to the bushing threads and screw finger tight into the pump.
 - d. To ensure a watertight seal, apply Loctite® 425 Assure™ threadlocker supplied with the leak sensor kit to the leak sensor threads and screw the leak sensor into the bushing.
 - e. Verify that the leak sensor was properly oriented in the pump so that the arrows imprinted on the leak sensor hex head are vertical positioned with the arrows pointing down. It may be necessary to further tighten both the bushing and leak sensor to achieve proper positioning.
 - f. Use an ohmmeter attached to the leak sensor leads to test the conductivity of the leak sensor. Continuity is affirmed by a reading of 0-5 ohms. Attach the leak sensor wires to the VFD or other monitoring device.
 - g. Apply air pressure to the pump and use a soapy solution around the bushing to ensure an air tight seal. If air bubbles appear, it will be necessary to return to the steps above for air pressure relief and removing the bushing from the pump. Apply new thread sealer on the bushing and install in the pump so that the leak sensor is properly positioned. Repeat this step to test for air leakage around the bushing.
4. If the continuity tests result indicate that the leak sensor is not functioning properly, proceed to step 3. Otherwise, tighten the bushing to its original position so that the arrows on the leak sensor point down. Attach the removed leak sensor wires to the point where they were disconnected from the VFD or other monitoring device.
5. Apply air pressure to the pump and use a soapy solution around the bushing to ensure an air tight seal. If air bubbles appear, it will be necessary to return to the steps above for air pressure relief and removing the bushing from the pump. Apply new thread sealer on the bushing and install in the pump so that the leak sensor is properly positioned. Repeat this step to test for air leakage around the bushing.



t133058a

Normal operation position shown by dark float. Lighter float line indicates the open circuit position.

Replace the Compressor

				
<p>To avoid injury from fire, explosion, or electric shock, all electrical wiring must be done by a qualified electrician and comply with all local codes and regulations.</p>				

1. Follow the [Pressure Relief Procedure](#), page 11.
2. Remove electrical power from the pump.
3. Remove the 8 bolts holding the pump to the mounting surface.
4. Tip the pump on its side to provide access to the compressor box.
5. Remove riser bracket (35).
6. Remove the air line (A1) from the compressor. Disconnect the compressor wires at the terminal block (L1, L2, and ground). Remove the four bolts, and carefully pull the compressor out of the box.
7. Use the four bolts to install the new compressor. Connect the air line from A1 to A1, as shown.
8. Connect the wires from the new compressor to the terminal block, as shown.
9. Replace riser bracket.
10. Return the pump to its mounting location. Secure it with the 8 bolts.
11. Return power to the pump.

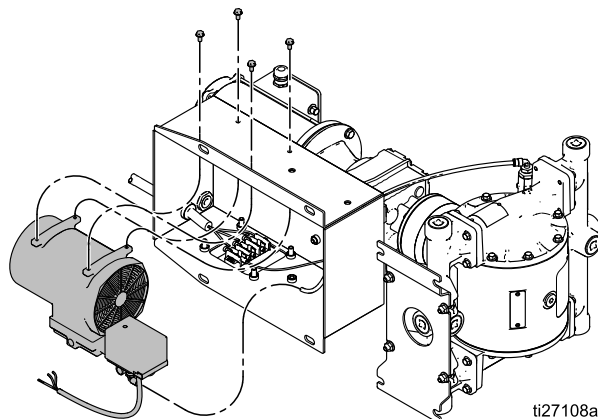

ti27108a

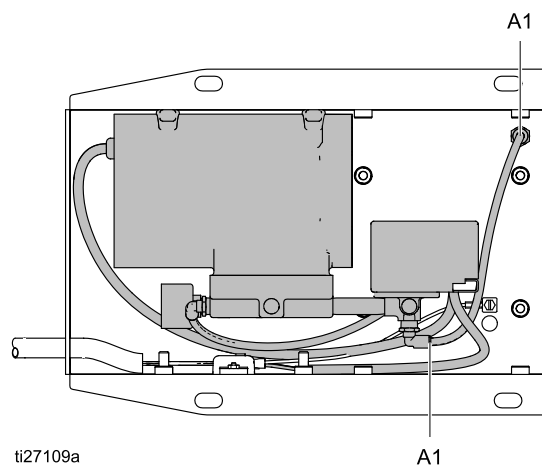

ti27109a

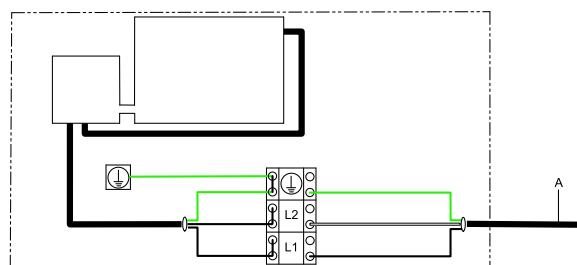

Torque Instructions

If fluid cover or manifold fasteners have been loosened, it is important to torque them using the following procedure to improve sealing.

NOTE: Fluid cover and manifold fasteners have a thread-locking adhesive patch applied to the threads. If this patch is excessively worn, the fasteners may loosen during operation. Replace screws with new ones or apply medium-strength (blue) thread locker to the threads.

NOTE: Always completely torque fluid covers before torquing manifolds.

1. Start all fluid cover screws a few turns. Then, turn down each screw just until head contacts cover.
2. Turn each screw by 1/2 turn or less working in a crisscross pattern to specified torque.
3. Repeat for manifolds.

Torque sequence

Aluminum Pumps

1. Left/Right Fluid Covers

Torque bolts to 200-210 in-lb (22.6–23.7 N•m)

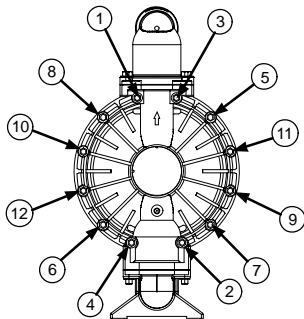

SIDE VIEW

2. Inlet Manifold

Torque bolts to 130-140 in-lb (14.7–15.8 N•m)

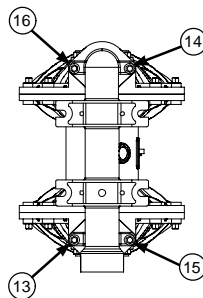

BOTTOM VIEW

3. Outlet Manifold

Torque bolts to 130-140 in-lb (14.7–15.8 N•m)

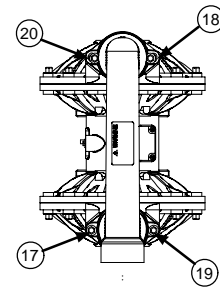

TOP VIEW

Stainless Steel and Ductile Iron Pumps

1. Left/Right Fluid Covers

Torque bolts to 200-210 in-lb (22.6–23.7 N•m)

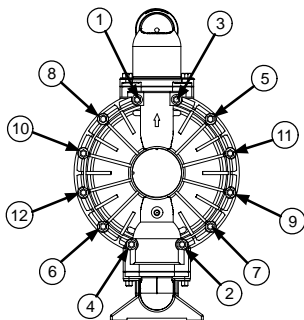

SIDE VIEW

2. Inlet Manifold

Torque bolts to 200-210 in-lb (22.6–23.7 N•m)

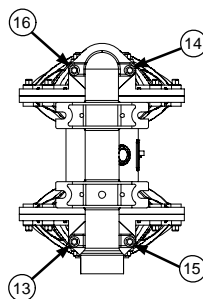

BOTTOM VIEW

3. Outlet Manifold

Torque bolts to 200-210 in-lb (22.6–23.7 N•m)

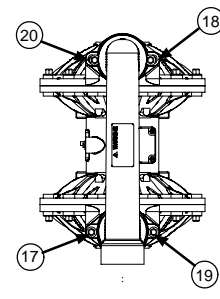

TOP VIEW

Plastic Pumps

1. Left/Right Fluid Covers

Torque bolts to 200-210 in-lb
(22.6–23.7 N•m)

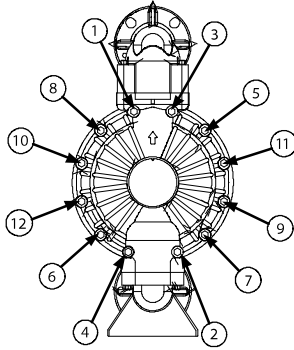

SIDE VIEW

2. Inlet Manifold

Torque bolts to 150-160 in-lb
(17–18 N•m)

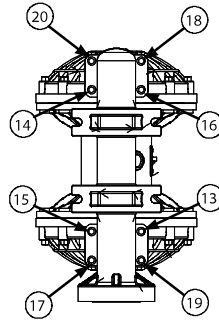

BOTTOM VIEW

3. Outlet Manifold

Torque bolts to 150-160 in-lb
(17–18 N•m)

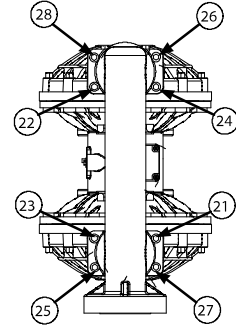

TOP VIEW

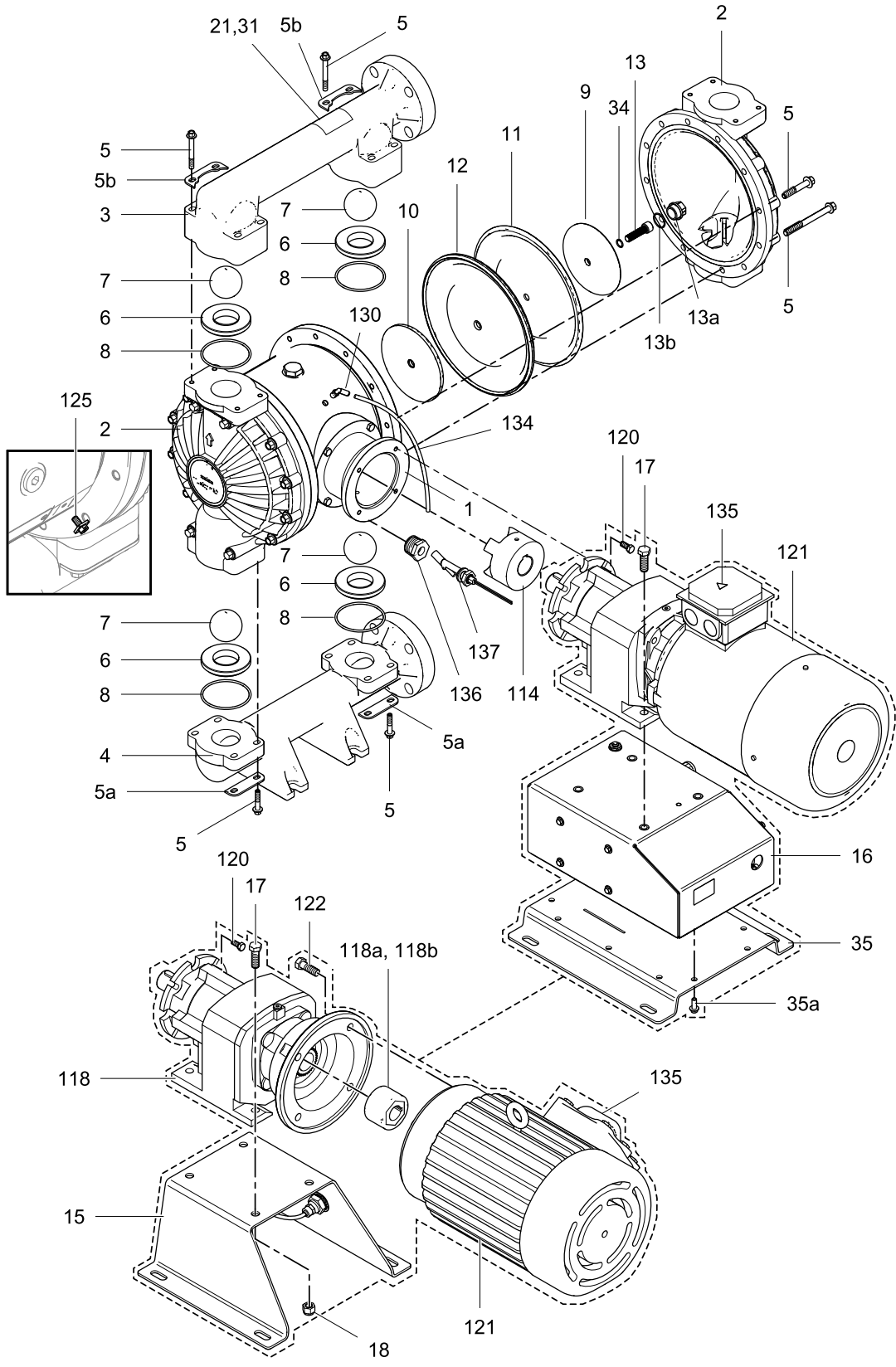

t31477a

Parts/Kits Quick Reference

Use this table as a quick reference for parts/kits. Go to the pages indicated in the table for a full description of kit contents.

Ref.	Part/Kit	Description	Qty.
1	---	MODULE, drive; <i>See pages 30-31.</i>	1
2	---	COVER, fluid; <i>See page 32.</i>	2
3	---	MANIFOLD, outlet; <i>See pages 32-33</i>	1
4	---	MANIFOLD, inlet; <i>See pages 32-33</i>	1
5		FASTENERS:	
		Aluminum fluid section	
	115644	Fluid Cover, M10 x 1.5, 35 mm	16
	115645	Fluid Cover, M10 x 1.5, 90 mm	8
	115644	Outlet Manifold, M10 x 1.5, 35 mm	4
	115644	Inlet Manifold, M10 x 1.5, 35 mm	4
		Conductive Poly, Poly, and PVDF fluid section	
	112368	Fluid cover, M10 x 1.5, 60 mm	16
	114181	Fluid cover, M10 x 1.5, 110 mm	8
	112560	Outlet Manifold, M8 x 1.25, 70 mm	8
	112559	Inlet Manifold, M8 x 1.25, 40 mm	8
		Stainless Steel and Ductile Iron fluid section	
	112416	Fluid cover, M10 x 1.5, 35 mm	16
	112417	Fluid cover, M10 x 1.5, 110 mm	8
	112416	Outlet Manifold, M10 x 1.5, 35 mm	4
	112416	Inlet Manifold, M10 x 1.5, 35 mm	4
5a	15J380	WASHER. inlet manifold	4
5b	15J379	WASHER. outlet manifold	4
6	---	SEAT; <i>See page 34.</i>	4
7	---	BALLS, <i>See page 34.</i>	4

Ref.	Part/Kit	Description	Qty.
8	112358	O-RING, manifold, (not used on some models); PTFE, <i>See page 36.</i> Used with the following seats: Geolast seats Polypropylene seats PVDF seats Santoprene seats 316 SST seats	4
9		PLATE, fluid side;	2
	262025	Aluminum, Ductile Iron	
	189299	Stainless Steel fluid section	
	25B444	Conductive Poly, Poly (includes Ref 13a, 13b)	
	25B450	PVDF (includes Ref 13a, 13b)	
10	25B445	PLATE, air side	2
11		DIAPHRAGM, kit; <i>See page 35.</i>	1 kit
12	---	DIAPHRAGM, backup, <i>included with Ref. 11 where needed</i>	2
13	25B443	BOLT, shaft; kit; <i>includes Ref. 34</i>	2
13a	---	PLUG, <i>included in 9, where needed</i>	2
13b	---	O-RING, <i>included in 9, where needed</i>	2
15		BRACKET, gear box, for models without compressor; includes refs 17 and 18 for aluminum or ductile iron fluid section 25B422 stainless steel fluid section 25B423 for conductive poly, poly, or PVDF fluid section 25B424	1
16		COMPRESSOR, assembly; <i>includes Ref. 16a</i> 25B431 120 Volt 25B432 240 Volt	1
16a		COMPRESSOR 24Y544 120 Volt 24Y545 240 Volt	1
17	EQ1519	BOLT, hex washer head, M8-1.25 x 32 mm; <i>included with Ref. 15</i>	4
18	EQ1475	NUT; <i>included with Ref. 15 or 16</i>	4

Ref.	Part/Kit	Description	Qty.
21▲	188621	LABEL, warning	1
31▲	198382	LABEL, warning, multilingual	1
34	— — —	O-RING, for diaphragm shaft bolt; <i>included with Ref. 13</i>	2
35		BRACKET, riser; <i>used for models with a compressor; includes Ref 35a</i>	1
	25B427	for aluminum or ductile iron fluid section	
	25B428	for stainless steel fluid section	
	25B429	for conductive poly, poly, or PVDF fluid section	

Ref.	Part/Kit	Description	Qty.
35a	— — —	BOLT, M8 x 1.25, 20mm	10
42	114862	NUT; <i>for manifold bolts on models with stainless steel fluid section</i>	8

— — — *Not sold separately.*

▲ Replacement Warning labels, signs, tags, and cards are available at no cost.

Center Section

Sample Configuration Number

Pump Model	Wetted Section Material	Drive	Center Section Material	Gear Box and Motor	Motor	Fluid Covers and Manifolds	Seats	Balls	Diaphragms	Manifold O-Rings
2150	A	E	A	04	A	A1	TP	TP	TP	--

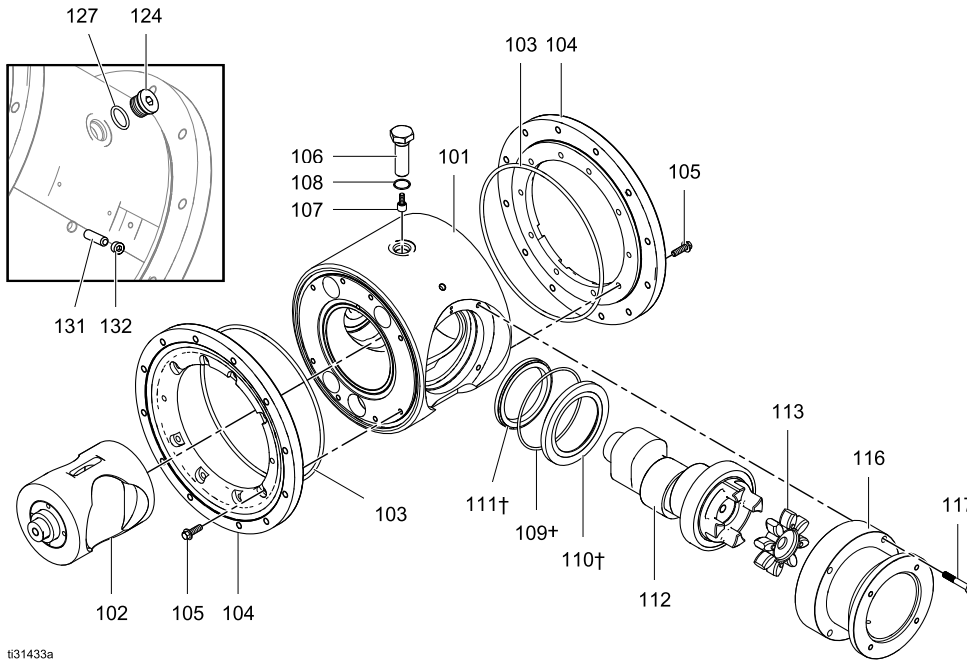

Ref	Part	Description	Qty
101	25B415 25B416	HOUSING, center, assembly; <i>includes plugs Aluminum (Axx) Stainless Steel (Sxx); also includes o-ring</i>	1
102	25B400	PISTON, assembly	1
103	— — —	O-RING, air cover; <i>included with ref 104</i>	2
104	25B440 25B441	AIR COVER Aluminum center section <i>includes refs 103, 105</i> SST center section <i>includes refs 103, 105</i>	2
105	— — —	BOLT, air cover <i>included with ref 104</i>	16
106	25B419	BOLT, bearing; <i>includes Refs. 107 and 108</i> for aluminum center housing	1
107	— — —	BEARING, cam follower. <i>included with Ref. 106</i>	1
108	— — —	O-RING, Size 019, Fluoroelastomer; <i>included with Ref. 106</i>	1
109†	— — —	O-RING, Size 153, Buna-N	1
110†	— — —	CARTRIDGE, seal	1
111†	— — —	SEAL, radial	1
112	25B414	SHAFT, drive, assembly; <i>includes o-ring (Ref. 109), cartridge (Ref. 110) and seal (Ref. 111)</i>	1
113	25B413	COUPLER, shaft	1
114	17S683	COUPLER, gearbox; <i>includes mounting hardware</i>	1
116	25B417 25B418	HOUSING, alignment, assembly; <i>includes screws (Refs. 117, 120) Aluminum (Axx) Stainless steel (Sxx)</i>	1
117	— — —	SCREW, socket head, M8 x 50 mm; <i>included with Ref. 116</i>	4

Ref	Part	Description	Qty
118	25B410 25B411 25B412	GEARBOX; <i>includes Ref 118a, 118b, 122</i> low speed medium speed high speed	1
118a	— — —	COUPLER; <i>included with Ref 118</i>	1
118b	— — —	KEY; <i>included with Ref 118</i>	1
120	— — —	SCREW, cap, hex head, M8 x 20 mm	4
121	25B401 25B402 25B403 25B406 25B405 25B404 25B409 25B408 25B407	MOTOR low speed gearmotor medium speed gearmotor high speed gearmotor low speed ATEX medium speed ATEX high speed ATEX low speed flameproof medium speed flameproof high speed flameproof	1
122	— — —	SCREW, cap, 1/2–13 x 1.5 in.	4
124	24Y534	PLUG, front access <i>includes ref 127</i>	1
125	— — —	SCREW, ground, M5 x 0.8	1
127	— — —	O-RING <i>included with Ref 124</i>	1
130	— — —	ELBOW, 1/8–27 npt	1
131	— — —	PIN, stop, 5/16 x 1-1/4 in.	1
132	— — —	PLUG; 1/8–27 npt	1
135	189930	LABEL, caution	1
136	— — —	BUSHING <i>included with Ref 137</i>	
137	25B435	Leak sensor <i>includes Ref 136</i>	

— — — Not sold separately.

† Included in Shaft Seal Repair Kit 25B420.

Fluid Covers and Manifolds

Sample Configuration Number

Pump Model	Wetted Section Material	Drive	Center Section Material	Gear Box and Motor	Motor	Fluid Covers and Manifolds	Seats	Balls	Diaphragms	Manifold O-Rings
2150	A	E	A	04	A	A1	TP	TP	TP	--

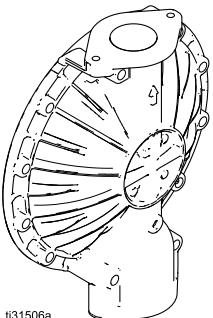
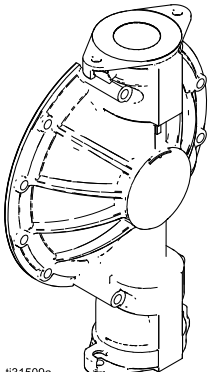
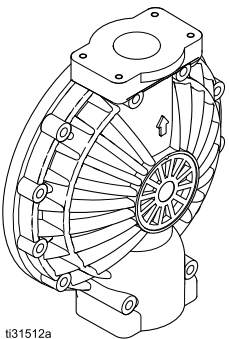
Fluid Cover Kits		
Kits include: 1 fluid cover (2)		
Aluminum, SST, Ductile Iron		
A1, A2	15A612	 t31506a
I1, I2	191541	
S1, S2	194279	 t31509a
Conductive Polypropylene, Polypropylene, and PVDF		
C2	120969	 t31512a
P2	189793	
F2	189795	

NOTE: Outlet manifolds include a Warning label. Replacement warning labels, signs, tags, and cards are available at no cost.

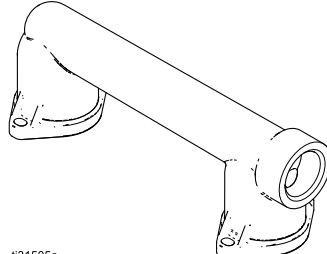
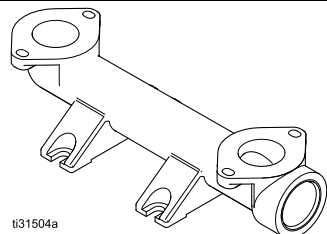
Aluminum Manifold Kits		
Kits include: 1 manifold		
Outlet (3)		 t31505a
A1	15A613	
A2	15A614	
Inlet (4)		 t31504a
A1	189302	
A2	192086	

Sample Configuration Number

Pump Model	Wetted Section Material	Drive	Center Section Material	Gear Box and Motor	Motor	Fluid Covers and Manifolds	Seats	Balls	Diaphragms	Manifold O-Rings
2150	A	E	A	04	A	A1	TP	TP	TP	--

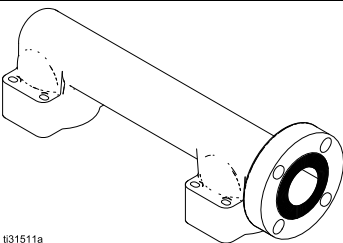
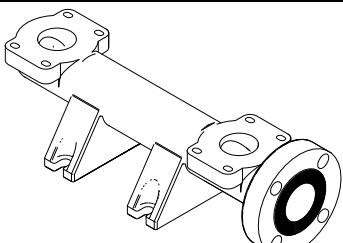
Conductive Polypropylene, Polypropylene, and PVDF Manifold Kits		
Kits include: 1 manifold)		
End Flange Outlet (3)		
C2	120971	 i31511a
F2	189792	
P2	189790	
End Flange Inlet (4)		
C2	120970	 i31510a
F2	189789	
P2	189787	

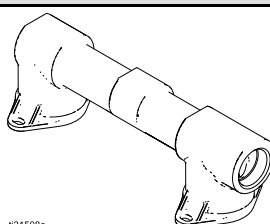
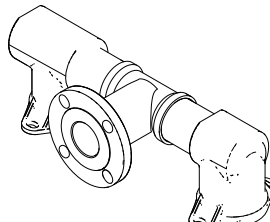
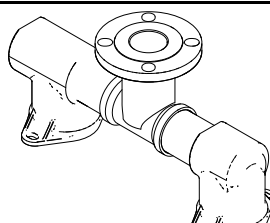
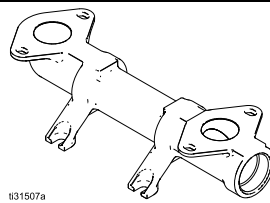
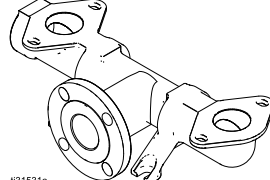
Ductile Iron and Stainless Steel		
Kits include: 1 manifold)		
Outlet (3)		
I1	191543	 i31508a
I2	192089	
S1	194281	
S2	195577	
S5-1	17N103	 i31532a
S5-2	17N153	 i31533a
Inlet (4)		
I1	191542	 i31507a
I2	192088	
S1	194280	
S2	195576	
S5-1, S5-2	17N102	 i31531a

Seats and Check Balls

Sample Configuration Number

Pump Model	Wetted Section Material	Drive	Center Section Material	Gear Box and Motor	Motor	Fluid Covers and Manifolds	Seats	Balls	Diaphragms	Manifold O-Rings
2150	A	E	A	04	A	A1	TP	TP	TP	- -

Seat Kits	
GE	194215
PP	189291
PV	189745
SP	189290
SS	189288
TP	189292

Kits include:

- 1 seat, material indicated in table.

Ball Kits	
AC	112363
CW	15H834
GE	114753
PT	112359
SD	112360
SP	112361
TP	112745

Kits include:

- 1 ball, material indicated in table.

Diaphragms

Sample Configuration Number

Pump Model	Wetted Section Material	Drive	Center Section Material	Gear Box and Motor	Motor	Fluid Covers and Manifolds	Seats	Balls	Diaphragms	Manifold O-Rings
2150	A	E	A	04	A	A1	TP	TP	TP	--

Bolt-Through Diaphragm Kits	
GE	25B437
PT	25B439
SP	25B436
TP	25B438

Kits include:

- 2 diaphragms (11)
- 2 diaphragms (12)
- 1 packet anaerobic adhesive

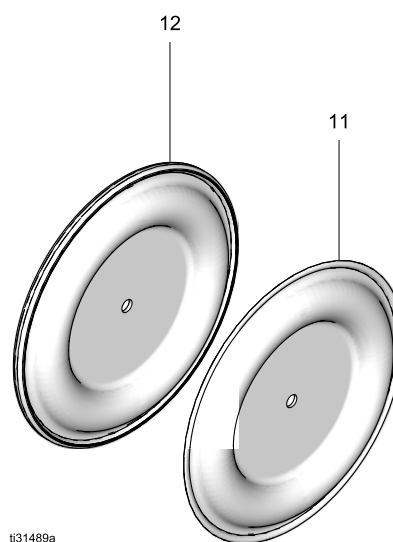

Manifold Seals

Sample Configuration Number

Pump Model	Wetted Section Material	Drive	Center Section Material	Gear Box and Motor	Motor	Fluid Covers and Manifolds	Seats	Balls	Diaphragms	Manifold O-Rings
2150	A	E	A	04	A	A1	PT	PT	PT	PT

O-Ring Kits	
PT	112358

Kits include:

- 8 o-rings (9), PTFE; not used on models with Buna-N, FKM, or TPE seats.

Kits and Accessories

Center Section Repair Tool Kit 25B434

Includes tools needed to remove the bearing from the center section.

Bearing Puller Kit 17J718

Includes an interchangeable bearing puller set.

Technical Data

Husky Electric Double Diaphragm Pump		
	US	Metric
Maximum fluid working pressure	100 psi	0.69 MPa, 6.9 bar
Air pressure operating range	20 to 100 psi	0.14 to 0.69 MPa, 1.4 to 6.9 bar
Air inlet size	3/8 in. npt(f)	
Maximum suction lift (reduced if balls don't seat well due to damaged balls or seats, lightweight balls, or extreme speed of cycling)	Wet or Dry: 18 ft	Wet or Dry: 5.5 m
Maximum size pumpable solids	1/4 in.	6.3 mm
Minimum ambient air temperature for operation and storage. NOTE: Exposure to extreme low temperatures may result in damage to plastic parts.	32° F	0° C
Fluid displacement per cycle (free-flow)	0.6 gallons	2.27 liters
Maximum free-flow delivery (continuous duty)	100 gpm	378 lpm
Maximum pump speed (continuous duty)	160 cpm	
Fluid Inlet and Outlet Size		
Polypropylene, Conductive Polypropylene, PVDF, or SST Flange	DIN PN16 050–2 in. ANSI 150 2 NPS JIS 10K 50	
Aluminum, Stainless Steel, Cast Iron	2 in npt(f) or 2 in bspt	
Electric Motor		
AC, Standard CE (04A, 05A, 06A)		
Power	7.5 HP	5.5 kW
Number of Motor Poles	4–Pole	
Speed	1800 rpm (60 Hz) or 1500 rpm (50 Hz)	
Constant Torque	6:1	
Gear Ratio	11.25	
Voltage	3–phase 230V / 3–Phase 460V	
Maximum Amperage Load	19.5 A (230V) / 9.75 A (460V)	
IE Rating	IE3	
AC, Standard CE (14A, 15A, 16A)		
Power	5.0 HP	3.7 kW
Number of Motor Poles	4–Pole	
Speed	1800 rpm (60 Hz) or 1500 rpm (50 Hz)	
Constant Torque	6:1	
Gear Ratio	16.46	
Voltage	3–phase 230V / 3–Phase 460V	
Maximum Amperage Load	13.0 A (230V) / 6.5 A (460V)	
AC, Standard CE (24A, 25A, 26A)		
Power	3.0 HP	2.2 kW
Number of Motor Poles	4–Pole	
Speed	1800 rpm (60 Hz) or 1500 rpm (50 Hz)	

Technical Data

Constant Torque	6:1	
Gear Ratio	26.77	
Voltage	3-phase 230V / 3-Phase 460V	
Maximum Amperage Load	7.68 A (230V) / 3.84 A (460V)	
IE Rating	IE3	
AC, ATEX (04C)		
Power	7.5 HP	5.5 kW
Number of Motor Poles	4-Pole	
Speed	1800 rpm (60 Hz) or 1500 rpm (50 Hz)	
Constant Torque	6:1	
Gear Ratio	11.88	
Voltage	3-phase 240V / 3-Phase 415V	
Maximum Amperage Load	20 A (230V) / 11.5 A (460V)	
AC, ATEX (14C)		
Power	5.0 HP	4.0 kW
Number of Motor Poles	4-Pole	
Speed	1800 rpm (60 Hz) or 1500 rpm (50 Hz)	
Constant Torque	6:1	
Gear Ratio	16.46	
Voltage	3-phase 240V / 3-Phase 415V	
Maximum Amperage Load	14.7 A (230V) / 8.5 A (460V)	
AC, ATEX (24C)		
Power	3.0 HP	2.2 kW
Number of Motor Poles	4-Pole	
Speed	1800 rpm (60 Hz) or 1500 rpm (50 Hz)	
Constant Torque	6:1	
Gear Ratio	26.77	
Voltage	3-phase 240V / 3-Phase 415V	
Maximum Amperage Load	8.5 A (230V) / 5.0 A (460V)	
AC, Explosionproof (04D)		
Power	7.5 Hp	5.5 kW
Number of Motor Poles	4-Pole	
Speed	1800 rpm (60 Hz) or 1500 rpm (50 Hz)	
Constant Torque	6:1	
Gear Ratio	11.88	
Voltage	3-phase 230V / 3-Phase 460V	
Maximum Amperage Load	20.0 A (230V) / 10.0 A (460V)	
AC, Explosionproof (14D)		
Power	5.0 Hp	3.7 kW
Number of Motor Poles	4-Pole	
Speed	1800 rpm (60 Hz) or 1500 rpm (50 Hz)	
Constant Torque	6:1	
Gear Ratio	16.46	

Voltage	3-phase 230V / 3-Phase 460V	
Maximum Amperage Load	13.0 A (230V) / 6.5 A (460V)	
AC, Explosionproof (24D)		
Power	3.0 Hp	2.2 kW
Number of Motor Poles	4-Pole	
Speed	1800 rpm (60 Hz) or 1500 rpm (50 Hz)	
Constant Torque	6:1	
Gear Ratio	26.77	
Voltage	3-phase 230V / 3-Phase 460V	
Maximum Amperage Load	8 A (230V) / 4 A (460V)	
Leak Sensor		
Contact Ratings:		
State	Normally closed	
Voltage	240V Max (AC/DC)	
Current	0.28 A max at 120 VAC 0.14 A max at 240 VAC 0.28 A max at 24 VDC 0.07 A max at 120 VDC	
Power	30 W max	
Ambient Temperature	-20° to 40°C (-4° to 104°F)	
Ex Ratings:		
Classification: "simple apparatus" in accordance with UL/EN/IEC 60079-11, clause 5.7		
Class I, Group D, Class II, Group F&G, Temp Code T3B		
		
II 2 G Ex ib IIC T3		
Parameters	$U_i = 24\text{ V}$ $I_i = 280\text{ mA}$ $P_i = 1.3\text{ W}$ $C_i = 2.4\text{ pF}$ $L_i = 1.00\text{ }\mu\text{H}$	
Noise Data		
Sound Power (measured per ISO-9614-2)		
at 90 psi fluid pressure and 80 cpm	84 dBa	
at 60 psi fluid pressure and 160 cpm (full flow)	92 dBa	
Sound Pressure [tested 3.28 ft (1 m) from equipment]		
at 90 psi fluid pressure and 80 cpm	74 dBa	
at 60 psi fluid pressure and 160 cpm (full flow)	82 dBa	
Wetted Parts		
Wetted parts include material(s) chosen for seat, ball, and diaphragm options, plus the pump's material of construction: Aluminum, Polypropylene, Stainless Steel, Conductive Polypropylene, or PVDF		
Non-wetted parts		
Non-wetted parts include aluminum, coated carbon steel, PTFE, stainless steel, polypropylene		

Weights

Pump Material		Motor/Gearbox																			
Fluid Section	Center Section	Standard AC						ATEX AC						Flameproof AC						No Gear-motor	
		04A		14A		24A		04C		14C		24C		04D		14D		24D		03G	
		lb	kg	lb	kg	lb	kg	lb	kg	lb	kg	lb	kg	lb	kg	lb	kg	lb	kg	lb	kg
Aluminum	Aluminum	280	127	112	51	103	46	418	189	122	55	94	42	440	199	157	71	153	69	125	56
Ductile Iron	Aluminum	329	149	161	73	152	69	467	211	171	78	143	65	489	221	206	93	202	91	174	78
Conductive Polypropylene	Aluminum	275	124	243	110	223	101	413	187	266	120	240	108	435	197	342	155	333	151	119	54
Conductive Polypropylene	Stainless Steel	357	161	325	147	305	138	495	224	348	157	322	146	517	234	424	192	415	188	201	91
Polypropylene	Aluminum	271	122	239	108	219	99	409	185	262	118	236	107	431	195	338	153	329	149	115	52
Polypropylene	Stainless Steel	353	160	321	145	301	136	491	222	344	156	318	144	513	232	420	190	411	186	197	89
PVDF	Aluminum	290	131	258	117	238	108	573	259	281	127	255	115	450	204	357	162	348	158	134	60
PVDF	Stainless Steel	372	168	340	154	320	145	655	297	363	164	337	152	532	241	439	199	430	195	216	98
Stainless Steel	Aluminum	342	155	310	140	290	131	737	334	333	151	307	139	502	227	409	185	400	181	184	83
Stainless Steel	Stainless Steel	424	192	392	177	372	168	819	371	415	188	389	176	584	264	491	222	482	218	266	120

Component/Model	U.S.	Metric
Compressor	28 lb	13 kg

Variable Frequency Drives (2 hp)

Model	Hp/kW	Input Voltage Range	Nominal Output Voltage †
17K696	3.0/2.2	170–264 Vac	208–240 Vac, 3 phase
17K697	3.0/2.2	340–528 Vac	400–480 Vac, 3 phase
25B446	5.0/4.0	170–264 Vac	208–240 Vac, 3 phase
25B447	5.0/4.0	340–528 Vac	400–480 Vac, 3 phase
25B448	7.5/5.5	170–264 Vac	208–240 Vac, 3 phase
25B449	7.5/5.5	340–528 Vac	400–480 Vac, 3 phase

† Output voltage is dependent on input voltage.

Fluid Temperature Range

NOTICE

Temperature limits are based on mechanical stress only. Certain chemicals will further limit the fluid temperature range. Stay within the temperature range of the most-restricted wetted component. Operating at a fluid temperature that is too high or too low for the components of your pump may cause equipment damage.

Diaphragm/Ball/Seat Material	Fluid Temperature Range					
	Aluminum Cast Iron, or Stainless Steel Pumps		Polypropylene or Conductive Polypropylene Pumps		PVDF Pumps	
	Fahrenheit	Celsius	Fahrenheit	Celsius	Fahrenheit	Celsius
Acetal (AC)	10° to 180°F	-12° to 82°C	32° to 150°F	0° to 66°C	10° to 180°F	-12° to 82°C
FKM Fluoroelastomer (FK)*	-40° to 275°F	-40° to 135°C	32° to 150°F	0° to 66°C	10° to 225°F	-12° to 107°C
Geolast® (GE)	-40° to 150°F	-40° to 66°C	32° to 150°F	0° to 66°C	10° to 150°F	-12° to 66°C
Polychloroprene check balls (CR or CW)	0° to 180°F	-18° to 82°C	32° to 150°F	0° to 66°C	10° to 180°F	-12° to 82°C
Polypropylene (PP)	32° to 150°F	0° to 66°C	32° to 150°F	0° to 66°C	32° to 150°F	0° to 66°C
PTFE check balls or two-piece PTFE/EPDM diaphragm (PT)	40° to 220°F	4° to 104°C	40° to 150°F	4° to 66°C	40° to 220°F	4° to 104°C
PVDF (PV)	10° to 225°F	-12° to 107°C	32° to 150°F	0° to 66°C	10° to 225°F	-12° to 107°C
Santoprene® check balls (SP)	-40° to 180°F	-40° to 82°C	32° to 150°F	0° to 66°C	10° to 225°F	-12° to 107°C
TPE (TP)	-20° to 150°F	-29° to 66°C	32° to 150°F	0° to 66°C	10° to 150°F	-12° to 66°C

* The maximum temperature listed is based on the ATEX standard for T4 temperature classification. If you are operating in a non-explosive environment, FKM fluoroelastomer's maximum fluid temperature in aluminum or stainless steel pumps is 320°F (160°C).

Graco Standard Husky Pump Warranty

Graco warrants all equipment referenced in this document which is manufactured by Graco and bearing its name to be free from defects in material and workmanship on the date of sale to the original purchaser for use. With the exception of any special, extended, or limited warranty published by Graco, Graco will, for a period of twelve months from the date of sale, repair or replace any part of the equipment determined by Graco to be defective. This warranty applies only when the equipment is installed, operated and maintained in accordance with Graco's written recommendations.

This warranty does not cover, and Graco shall not be liable for general wear and tear, or any malfunction, damage or wear caused by faulty installation, misapplication, abrasion, corrosion, inadequate or improper maintenance, negligence, accident, tampering, or substitution of non-Graco component parts. Nor shall Graco be liable for malfunction, damage or wear caused by the incompatibility of Graco equipment with structures, accessories, equipment or materials not supplied by Graco, or the improper design, manufacture, installation, operation or maintenance of structures, accessories, equipment or materials not supplied by Graco.

This warranty is conditioned upon the prepaid return of the equipment claimed to be defective to an authorized Graco distributor for verification of the claimed defect. If the claimed defect is verified, Graco will repair or replace free of charge any defective parts. The equipment will be returned to the original purchaser transportation prepaid. If inspection of the equipment does not disclose any defect in material or workmanship, repairs will be made at a reasonable charge, which charges may include the costs of parts, labor, and transportation.

THIS WARRANTY IS EXCLUSIVE, AND IS IN LIEU OF ANY OTHER WARRANTIES, EXPRESS OR IMPLIED, INCLUDING BUT NOT LIMITED TO WARRANTY OF MERCHANTABILITY OR WARRANTY OF FITNESS FOR A PARTICULAR PURPOSE.

Graco's sole obligation and buyer's sole remedy for any breach of warranty shall be as set forth above. The buyer agrees that no other remedy (including, but not limited to, incidental or consequential damages for lost profits, lost sales, injury to person or property, or any other incidental or consequential loss) shall be available. Any action for breach of warranty must be brought within two (2) years of the date of sale.

GRACO MAKES NO WARRANTY, AND DISCLAIMS ALL IMPLIED WARRANTIES OF MERCHANTABILITY AND FITNESS FOR A PARTICULAR PURPOSE, IN CONNECTION WITH ACCESSORIES, EQUIPMENT, MATERIALS OR COMPONENTS SOLD BUT NOT MANUFACTURED BY GRACO. These items sold, but not manufactured by Graco (such as electric motors, switches, hose, etc.), are subject to the warranty, if any, of their manufacturer. Graco will provide purchaser with reasonable assistance in making any claim for breach of these warranties.

In no event will Graco be liable for indirect, incidental, special or consequential damages resulting from Graco supplying equipment hereunder, or the furnishing, performance, or use of any products or other goods sold hereto, whether due to a breach of contract, breach of warranty, the negligence of Graco, or otherwise.

FOR GRACO CANADA CUSTOMERS

The Parties acknowledge that they have required that the present document, as well as all documents, notices and legal proceedings entered into, given or instituted pursuant hereto or relating directly or indirectly hereto, be drawn up in English. Les parties reconnaissent avoir convenu que la rédaction du présente document sera en Anglais, ainsi que tous documents, avis et procédures judiciaires exécutés, donnés ou intentés, à la suite de ou en rapport, directement ou indirectement, avec les procédures concernées.

Graco Information

For the latest information about Graco products, visit www.graco.com.
For patent information, see www.graco.com/patents.

To place an order, contact your Graco Distributor or call to identify the nearest distributor.

Phone: 612-623-6921 **or Toll Free:** 1-800-328-0211 **Fax:** 612-378-3505

All written and visual data contained in this document reflects the latest product information available at the time of publication.

Graco reserves the right to make changes at any time without notice.
Original Instructions. This manual contains English. MM 3A4068

Graco Headquarters: Minneapolis
International Offices: Belgium, China, Japan, Korea

GRACO INC. AND SUBSIDIARIES • P.O. BOX 1441 • MINNEAPOLIS MN 55440-1441 • USA
Copyright 2017, Graco Inc. All Graco manufacturing locations are registered to ISO 9001.

www.graco.com
Revision C, February 2018