



# Instructions

## Dispensit 792-20

---

332096A  
EN

### Dispense Valve



#### **Important Safety Instructions**

Read all warnings and instructions in this manual.  
Save these instructions.

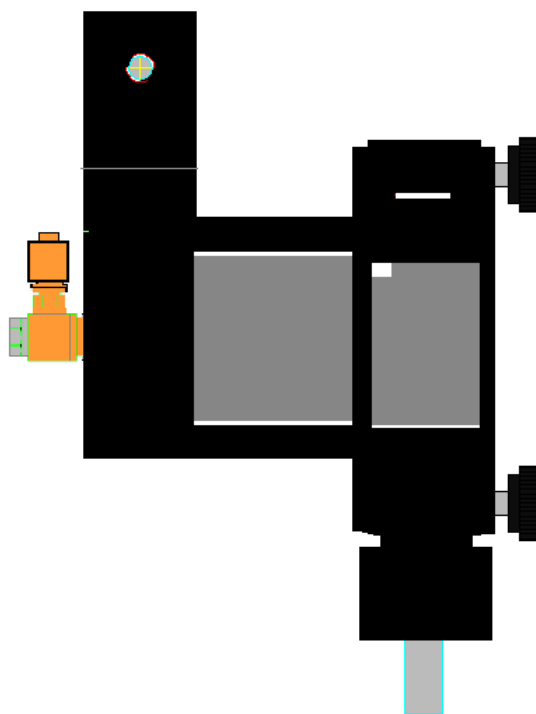

# MODEL 792-20 DISPENSE VALVE OPERATING & MAINTENANCE MANUAL

<b>General Information .....</b>	<b>3</b>
<b>Safety Information .....</b>	<b>3</b>
<b>Illustration References .....</b>	<b>3</b>
<b>General Accessories .....</b>	<b>3</b>
<b>Description Of Operation .....</b>	<b>4</b>
<b>Setup Procedures .....</b>	<b>4</b>
Mounting Dispense Valve .....	4
Air Controller.....	4
<b>Operating Procedures .....</b>	<b>5</b>
Dry System Checkout.....	5
Material Loading .....	5
Remote Mounted Material Supply .....	5
Wet System Checkout.....	6
<b>Periodic Maintenance.....</b>	<b>6</b>
Material Hose Renewal .....	6
Material Hose Replacement .....	7
Disassembly .....	8
Model 792-20 General Illustration.....	9
Assembly .....	10
<b>Troubleshooting .....</b>	<b>11</b>
<b>Model 792-20 Recommended Spare Parts.....</b>	<b>12</b>
<b>General Guidelines for O-rings and U-cup Seals.....</b>	<b>13</b>
<b>Warranty .....</b>	<b>14</b>

## GENERAL INFORMATION

The Model 792-20 Dispense Valve is designed for applications that require ON/OFF dispensing of beads and/or dots. It has dispensing capability for material viscosities ranging from water-type material to high viscosity epoxies and metal filled pastes. This valve also has a fail-safe design to prevent material dumping in case of a power failure. All wetted parts are disposable for easy maintenance and cleaning. The 792-20 ships complete with the following:

- Model 792-20 Dispense Valve
- One 3 foot (.9 m) section of pneumatic air line
- One material hose (type as ordered)
- Seal Kit
- Operating and Maintenance Manual

## SAFETY INFORMATION

This product should be used only by employees who have been given appropriate training and safety warnings as set forth in this manual. Read completely before operating.

**Warning:** Do not exceed 100 psi (6.9 bar) pressure on the operating system or 60 psi (4.1 bar) material supply pressure. Higher pressures are not required and may cause a serious hazard.

Toxicity and flammability hazards depend upon the product being dispensed by this unit, and the user should take appropriate safety precautions as indicated on the MSDS of the product.

Always wear safety glasses.

## ILLUSTRATION REFERENCES

Throughout this manual you will find references by illustration item number to the illustrations in the manual. The references are indicated by parentheses around a number such as: (7). Illustrations represent typical valve configurations. The drawings for your exact model are inserted at the back of the manual and include the part numbers for ordering replacement parts.

## GENERAL ACCESSORIES

Graco | Liquid Control offers a full line of standard and custom accessories for your dispensing needs including:

- Valve Controllers
- Syringe Feed Systems
- Cartridge Retainers and Pressure Reservoirs
- Transfer Pump Feed Systems for 1, 5 and 55 gallon containers
- Mounting Bases and Brackets

Consult your Dispensit dealer or the factory for details.

## DESCRIPTION OF OPERATION

1. The normal ready state of the system is as follows:
  - The syringe or remote reservoir contains the dispensable material.
  - The system has been purged, filling the material hose and needle with material.
  - The Pinch-off Piston (11) is not pressurized, but is held back by the Springs (10) closing the Material Hose (16) and holding back the dispensable material.
2. The dispense cycle begins when the controller is activated.
3. The Pinch-off Piston (11) moves forward to release the Material Hose (16) allowing material to flow.
4. To complete the dispense cycle, the Pinch-off Piston (11) is pushed back by the Springs (10), sealing the Material Hose (16) to prevent material drip. The system is again in the normal ready state.

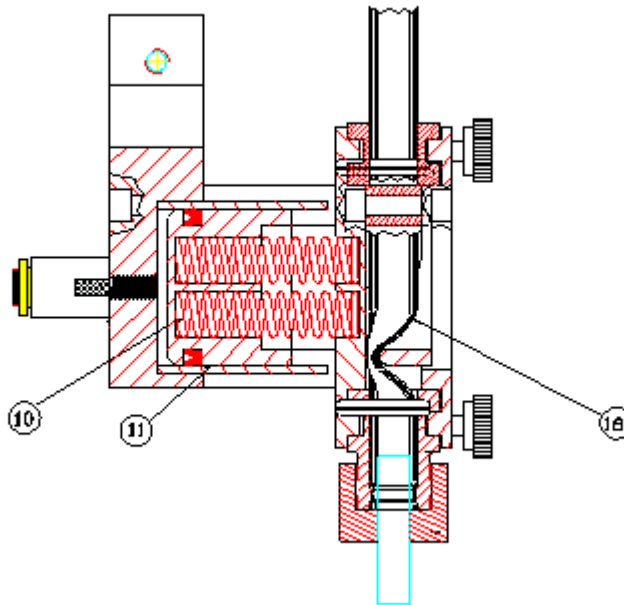

## SETUP PROCEDURES

### MOUNTING DISPENSE VALVE

For optimum operation, the Model 792-20 Dispense Valve must be mounted on a 1/2 inch (12.7 mm) support rod post or frame. When mounting, affix the valve firmly in place by tightening the socket head cap screw with a 5/32 inch Allen wrench. Depending on the application, the valve may be tilted to a maximum of 60° from the vertical.

### AIR CONTROLLER

Operation of the Model 792-20 Dispense Valve requires a controller that can provide the following:

- A minimum of 0.5 SCFM (2.3 cm<sup>3</sup>) of dry, unlubricated air at a minimum pressure of 4.8 bar (70 psi) and a maximum of 6.9 bar (100 psi).
- Time delay capability to allow the valve to cycle.
- Independent air pressure regulators for material reservoir and valve operation.
- “Purge capability” which is the ability for the operator to pass or not pass air to the Pinch-off Piston (11) on the dispense valve.
- For semiautomatic or automatic applications, a foot switch or other control to cycle the valve.
- Connection for .16” ID x .25” OD(6.35mm) pressure tubing for use between the dispense valve and controller.
- Connection for .16” ID x .25” OD(6.35mm) pressure tubing for use between the controller and syringe.

**NOTE:** The material supply must be regulated to a maximum of 60 psi (4.1 bar).

# OPERATING PROCEDURES

## DRY SYSTEM CHECKOUT

This is an initial checkout to determine if the setup has been properly completed.

Conduct the dry system checkout without any material in the system.

1. Attach the color-coded pneumatic pressure line from the air inlet fitting on the valve to the color-coded cycle air outlet on the air supply controller.
2. Turn on the electric and air supply.
3. Set the air pressure to 70 psi (4.8 bar) on the system pressure gauge.
4. In the normal rest position the Pinch-off Piston (11) is held back by the Springs (10), sealing the Material Hose (18).
5. Momentarily press the dispense valve cycling control switch. The Pinch-off Piston (11) is pressurized to release the Material Hose (18). The controller air solenoid valve should cycle and cause a slight fluctuation in the system pressure gauge. When this happens, the system is correctly installed.

## MATERIAL LOADING

### REMOTE MOUNTED MATERIAL SUPPLY

Connect the Material Hose either directly to the material supply reservoir or to material supply tubing that connects to the material supply reservoir. When using a remote reservoir, the material supply tubing and fittings must be compatible with the material being dispensed and be capable of withstanding the dispensing pressure.

**Warning:** Do not exceed 100 psi (6.9 bar) pressure on the operating system or 60 psi (4.1 bar) material supply pressure. Higher pressures are not required and may cause a serious hazard.

**WARNING:** Do not apply either operating or reservoir air pressure to the product unless all screws are in place and properly tightened, and the receiver cap and/or reservoir lid is properly in place and tightened. All air connections should be fastened securely.

## WET SYSTEM CHECKOUT

Using the purge cycle on the air supply controller, run the material through the dispense line until a smooth material flow is observed through the dispensing outlet.

After the purge cycle has been completed, set the air supply controller to the manual cycle mode and cycle the Dispense Valve several times.

# PERIODIC MAINTENANCE

## MATERIAL HOSE RENEWAL

Material hose life is difficult to predict due to its dependence on the cycles, speed, downtime and material dispensed. A common sign of a worn material hose is a reduction in shot volume. Inspect the material hose periodically and renew or replace as necessary.

Depending on the application layout it may be possible to renew the pinch area of the material hose by pulling it through the valve and trimming off the worn area.

1. Depressurize the material reservoir, and remove/disconnect it.
2. Pressurize the Pinch-off Piston (11). This is the purge mode. The Material Hose (16) will now be completely free of compression.
3. If your valve has a Hose Adapter (19), disconnect downstream fittings as required so that the Hose Adapter can be turned freely.
4. Remove the Hose Adapter (19) or Needle Assembly (18) from the Bottom Tube Adapter (17).
5. Pull the Material Hose (16) down through the valve to expose the worn pinch area on the Material Hose. Cut the Material Hose squarely above the worn pinch area and flush with the end of the the Bottom Tube Adapter (17).
6. Insert the steel end of the Hose Adapter (19) or Needle Assembly (18) into the end of the Material Hose (16) and tighten onto the Bottom Tube Adapter (17). Check all connections.
7. If your valve has a Hose Adapter (19), connect downstream fittings to it.
8. Connect the material reservoir and pressurize it.
9. Perform the Wet System Checkout and return to operation.

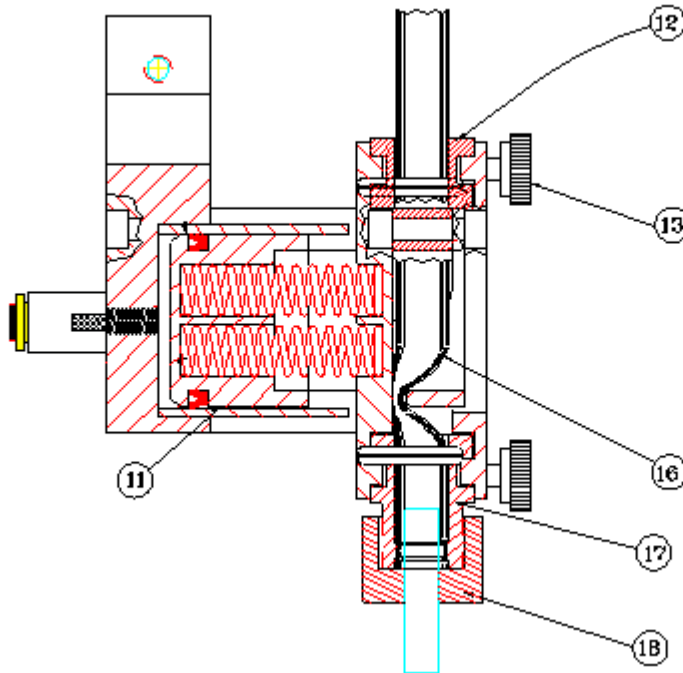

## PERIODIC MAINTENANCE

### MATERIAL HOSE REPLACEMENT

If material hose renewal is not feasible then follow these steps to replace the material hose.

**Note: To change the Material Hose, DO NOT disassemble the valve.**

1. Depressurize the material reservoir, and remove/disconnect it.
2. Pressurize the Pinch-off Piston (11). This is the purge mode. The Material Hose (16) will now be completely free of compression.
3. Loosen the upper and lower Knobs (13) enough to allow the Material Hose (16), Top Tube Adapter (12), and Bottom Tube Adapter (17) to pass out the side of the valve.
4. If your valve has a Hose Adapter (19), disconnect downstream fittings as required so that the Hose Adapter can be turned freely.
5. Depending on the valve configuration disconnect either the Needle Assembly (18) or Hose Adapter (19) from the Bottom Tube Adapter (17).
6. Remove the Bottom Tube Adapter (17) and Top Tube Adapter (12) from the Material Hose (16). Discard the old material hose.
7. Slide the Top Tube Adapter (12) hexagon end up onto the new Material Hose (16).
8. Slide Bottom Tube Adapter (17) onto the new Material Hose (16) until the hose is flush with the end of the adapter.
9. Depending on the valve configuration, insert the steel end of the Hose Adapter (19) or Needle Assembly (18) into the end of the Material Hose (16) and tighten onto the Bottom Tube Adapter (17).
10. Slide the Top Tube Adapter/Material Hose/Bottom Tube Adapter Assembly (12, 16 & 17) through the side of the valve.
11. Gently tighten the upper and lower Knobs (13).
12. Connect any downstream fittings that you disconnected from the Hose Adapter (19).
13. Connect the material reservoir and pressurize it.
14. Perform the Wet System Checkout and return to operation.

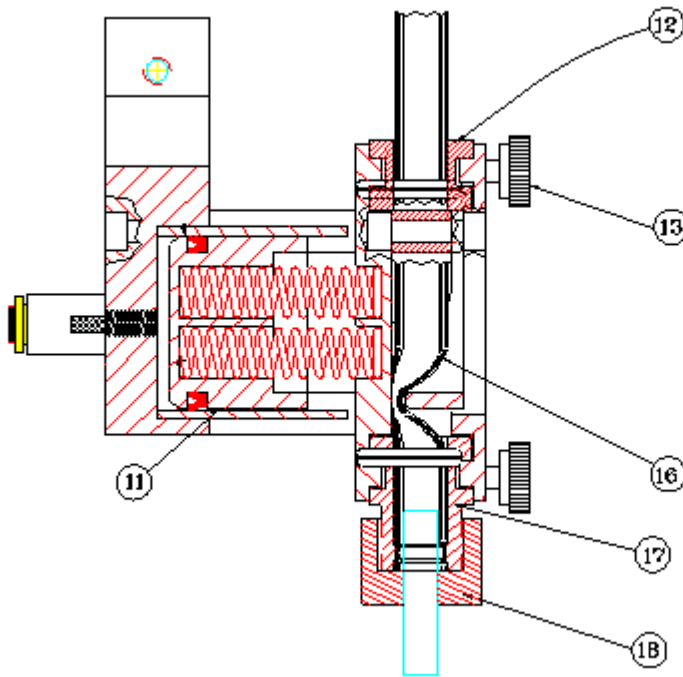

## PERIODIC MAINTENANCE

### DISASSEMBLY

Refer to the illustration below and to the drawings in the back of the manual for your exact model.

**Caution: Make sure you have your safety glasses on and that the valve is pointed away from you and others. The Springs can become flying objects if they escape your control.**

**Note: In addition to the items in the seal kit, the item most likely to require replacement is the Material Hose (16).**

1. Turn off the material supply pressure to the valve and disconnect the material supply.
2. Turn off the air supply pressure to the valve and disconnect the air supply line from the valve controller.
3. Remove the dispense valve from its mounting.
4. Loosen the upper and lower Knobs (13) enough to allow the Material Hose (16), Top Tube Adapter (12), and Bottom Tube Adapter (17) to pass out the side of the valve.
5. If your valve has a Hose Adapter (19), disconnect downstream fittings as required so that the Hose Adapter can be turned freely.
6. Depending on the valve configuration disconnect either the Needle Assembly (18) or Hose Adapter (19) from the Bottom Tube Adapter (17).
7. Remove the Bottom Tube Adapter (17) and Top Tube Adapter (12) from the Material Hose (16). Discard the old material hose.
8. Remove the Faceplate (15) by loosening and removing two Screws (3) holding it in place.

**NOTE: There are Springs (10) behind the Backplate (1). In the next step hold the Backplate (1) with your thumb over the Pinch-off Piston (11) while removing the Screws (2). Be careful, springs are in a compressed position.**

9. Loosen and remove two Screws (2) holding the Backplate (1) in place. The Backplate (1), the Pinch-off Piston (11), and its Springs (10) will come loose from the rest of the valve.
10. At this time all four Tie Rods (4) will be free and may be set aside.
11. Disassemble Backplate (1) from Pinch-off Piston (11).
12. Remove the U-cup Seal (7) from the Pinch-off Piston (11).



## MODEL 792-20 GENERAL ILLUSTRATION

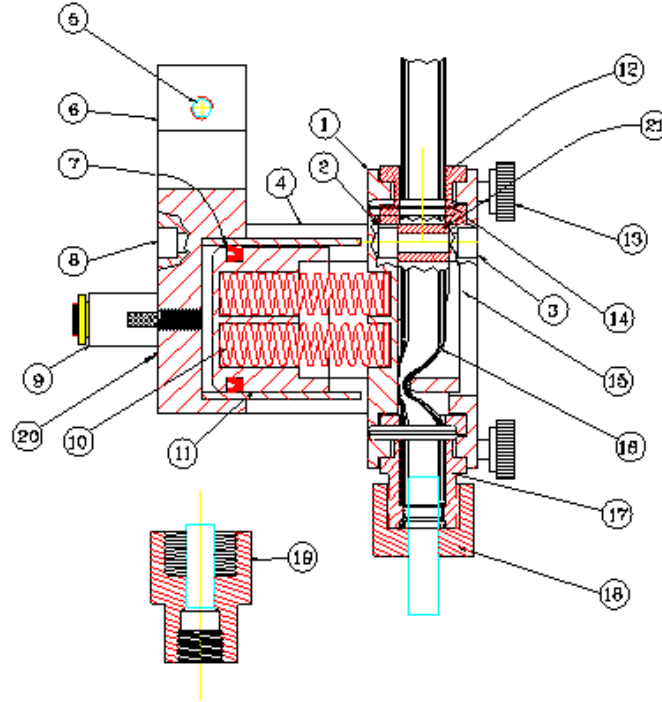

ITEM	QTY	DESCRIPTION
1	1	BACK PLATE
2	2	SCREW, #8-32 x 3/8
3	2	SCREW, # 8-32 x 1
4	4	TIE ROD
5	1	SCREW, #10-32 x 3/4
6	1	CYLINDER BASE ASSEMBLY
7	1	U-CUP SEAL
8	4	SCREW, #8-32 x 1
9	1	AIR INLET FITTING
10	2	SPRING
11	1	PINCH-OFF PISTON
12	1	TOP TUBE ADAPTER
13	2	KNOB
14	2	ROLL PIN, 1/8 x 3/4
15	1	FACEPLATE
16	1	MATERIAL HOSE
17	1	BOTTOM TUBE ADAPTER
18	1	NEEDLE ASSEMBLY option
19	1	HOSE ADAPTER option
20	1	GASKET
21	2	SPACER

## PERIODIC MAINTENANCE

### ASSEMBLY

Refer to the illustration above and to the drawings in the back of the manual for your exact model.

**Caution: Make sure you have your safety glasses on and that the valve is pointed away from you and others. The Springs (10) can become flying objects if they escape your control.**

**Note:** Clean all valve parts with an appropriate solvent prior to reassembly. Always install new, lubricated seals when assembling the valve. Use Krytox 203GPL (part number 84/0200-K3/11) for lubricating valve parts including seals. Lightly lubricate the inside bore of the Cylinder Base Assembly (6) and the outside of the Pinch-off Piston (11). Check the Pinch-off Piston (11) and Faceplate (15) for wear at the material hose contact area and if worn or distorted secure replacements before proceeding.

**Note:** Use caution as you install new U-cup seals so that they are not pinched or torn. Do this by making sure they are lubricated, and by tucking the lips of the seal inward before uniformly pushing them into position.

**Note what direction the old seals face as you remove them. Make sure the new seals face in the proper direction when you install them. Consult the drawings for orientation to be sure.**

1. Install the U-cup Seal (7) on the Pinch-off Piston (11).
2. Insert the Springs (10) into the Pinch-off Piston (11).
3. Set the Pinch-off Piston assembly on top of the Cylinder Base Assembly (6). Use a blunt tool to carefully tuck the U-cup Seal (7) in while easing the piston into the Cylinder Base Assembly (6). See *drawings for piston orientation*.
4. Compress the Springs (10) with a small screwdriver or other tool to assist in placing the Backplate (1) in position. Be sure the Springs (10) are centered under the Backplate (1).
5. Insert two of the Tie Rods (4) and install two Screws (2) and tighten them to tie the Backplate (1) down.
6. Place the Faceplate (15) onto the Backplate (1). See *drawing for orientation*. Slide the two Spacers (21) into position and install two Screws (3) through the faceplate and spacers and tighten them.
7. Slide the Top Tube Adapter (12) hexagon end up onto the new Material Hose (16).
8. Slide Bottom Tube Adapter (17) onto the new Material Hose (16) until the hose is flush with the end of the adapter.
9. Depending on the valve configuration, insert the steel end of the Hose Adapter (19) or Needle Assembly (18) into the end of the Material Hose (16) and tighten onto the Bottom Tube Adapter (17).
10. Slide the Top Tube Adapter/Material Hose/Bottom Tube Adapter Assembly (12, 16 & 17) through the side of the valve.
11. Gently tighten the upper and lower Knobs (13).
12. Mount the valve to its point of use.
13. Connect any downstream fittings that you disconnected from the Hose Adapter (19).
14. Connect the material reservoir and pressurize it.
15. Connect the air supply line to the valve controller.

**Perform the Dry System Checkout, Material Loading and Wet System Checkout.  
The valve is ready to be put back in service.**

## TROUBLESHOOTING

If operating difficulties are encountered, review the symptoms below. With each problem there are one or more possible causes that should be investigated to resolve the situation.

**NOTHING HAPPENS** - If absolutely nothing happens when trying to cycle the Dispense Valve, check the electric and pneumatic power. Check all control connections for proper installation.

**VALVE CYCLES, NOTHING DISPENSED** - First, try to purge the unit; this should fix most situations. If nothing is dispensed, check to see that there is enough pressure to the material reservoir. Perhaps the reservoir/material hose/needle path is clogged; examine and clear or replace as necessary. Consider whether the material could have “set up” in the system. Refer to the Wet System Checkout and Periodic Maintenance sections of this manual.

**IRREGULAR VOLUME DISPENSED** - Irregular dispensing can usually be attributed to faulty material. The material must be a smooth (homogeneous) mixture, without any air trapped in it. A second cause could possibly be that the material is not filling the material hose tube fully and in time. Check the reservoir pressure -- it may be too low for the type of material being dispensed and/or the cycle time may be set too fast. Cycle time is a function of the air supply controller. To adjust, follow the directions found in the controller operating manual.

**REDUCED VOLUMES DISPENSED** Check to see if material hose requires replacement or whether needle is partially clogged. (Refer to Periodic Maintenance Section).

**TUBING LIFE VERY SHORT** - Incorrect material hose (tube wall thickness too large).

**VALVE DRIPS** — Material hose needs replacing; wrong material hose used (wall thickness too small).

**SLOW OR SLUGGISH CYCLE TIME** - This may be due to inadequate lubrication of the piston walls. Remove the pinch-off piston. Apply a very thin film of Krytox lubricant (part number 84/0200-K3/11) to the outside diameter surfaces of the pistons and the U-seal and reassemble. This will restore smooth and consistent operation.

## MODEL 792-20 RECOMMENDED SPARE PARTS

**Note:** These parts are routine supply items or wear parts not covered by warranty for normal wear.

Quantity	Description	Part Number
1	SEAL KIT,792-20	<i>see assembly drawing for part number</i>
**	KRYTOX 203GPL ASSEMBLY LUBRICANT	84/0200-K3/11
<b>Material Hoses</b>		
<b>Custom Material Hoses Available - Consult Factory</b>		
Quantity	Description	Part Number
	5218 - HP .170 - 0 - 1/4 NPTM x 3.5'	A1020214
**	5218 - HP .170 - 0 - 1/8 NPTM x 3.5'	A1020215
**	5218 - HP .250 - 0 - 1/4 NPTM x 3.5'	A1020216
**	5218 - HP .250 - 0 - 1/8 NPTM x 3.5'	A1020217
**	5218 - PE .188 - 0 - 1/4 NPTM x 3.5'	A1020142
**	5218 - PE .188 - 0 - 1/8 NPTM x 3.5'	A1020141
**	5218 - PE .250 - 0 - 1/4 NPTM x 3.5'	A1020218
**	5218 - PE .250 - 0 - 1/8 NPTM x 3.5'	A1020219

*\*\* The quantity may vary for your application.*

## GENERAL GUIDELINES FOR O-RINGS AND U-CUP SEALS

Sizes and materials of construction for O-rings and U-cup seals are selected by Graco | Liquid Control based on compatibility with the chemicals to which they will be exposed. Solvents that may remove residual chemicals often have negative effects on the mechanical properties of O-rings and seals.

### O-Ring Guidelines

- Always replace an O-ring with the identical one in size, durometer hardness, type and material of construction. Always be alert to the location and size of each O-ring as many look alike and be careful not to mix them. Often similar sizes may be used in various locations on the equipment and if replaced incorrectly, the equipment may not function properly. Refer to the Machine Operation and Service Manual for the correct part number of all O-rings used throughout the equipment and replace them with factory approved parts only.
- Re-use of O-rings is not recommended. Only re-use O-rings as a last resort. If you must re-use them, be sure that they are clean, have no cuts or flat spots and contain NO foreign material. Also, be sure not to soak them in solvent for extended periods as this can cause deterioration of the O-ring. Always replace O-rings that are cut, nicked, or distorted in shape or cross-section.
- Always apply a very thin film of Krytox 203GPL lubricant, item 84/0200-K3/11, to the entire surface of the o-ring before installation. Avoid excessive lubrication. If installing O-rings over threads on a shaft or across sharp edges, roll or push the O-ring carefully into place being careful to avoid cutting or nicking it.
- Avoid stretching the O-ring too much as it may not return to the proper size.
- Do not use any sharp tools or objects to install O-rings

### U-cup Seal Guidelines

- Always replace a U-cup seal with the identical one in size, durometer hardness, type and material of construction. Always be alert to the location and size of each U-cup seal as many look alike and be careful not to mix them. Often similar sizes may be used in various locations on the equipment and if replaced incorrectly, the equipment may not function properly. Refer to the Machine Operation and Service Manual for the correct part number of all U-cups used throughout the equipment and replace them with factory approved parts only.
- Always apply a very thin film of Krytox 203GPL lubricant, item 84/0200-K3/11, to the inner and outer lips of the seal before installation.
- Re-use of U-cup seals is not recommended. Only re-use U-cups as a last resort. If you must re-use them, be sure that they are clean, have no cuts or flat spots and contain NO foreign material. Also, be sure not to soak them in solvent for extended periods as this can cause deterioration of the seal. Always replace U-cups that are cut, have flat spots, are distorted in shape or are damaged in any manner.
- Always be alert to the proper orientation of the sealing lips and re-install them in the same direction as shown on the specific equipment assembly drawing. The U-cup seals are intended to seal in only one direction and if installed incorrectly, chemical leakage through the U-cup can occur.
- Whenever possible, push the back side of the seal over the shaft to protect the inner and outer lips. If this is not possible, carefully tuck the lip in to avoid rolling it back or cutting it.
- If installing over sharp edges, slide the seal carefully into place to avoid cutting it.
- Do not use any sharp tools or objects to install U-cups.

# Graco Standard Warranty

Graco warrants all equipment referenced in this document which is manufactured by Graco and bearing its name to be free from defects in material and workmanship on the date of sale to the original purchaser for use. With the exception of any special, extended, or limited warranty published by Graco, Graco will, for a period of twelve months from the date of sale, repair or replace any part of the equipment determined by Graco to be defective. This warranty applies only when the equipment is installed, operated and maintained in accordance with Graco's written recommendations.

This warranty does not cover, and Graco shall not be liable for general wear and tear, or any malfunction, damage or wear caused by faulty installation, misapplication, abrasion, corrosion, inadequate or improper maintenance, negligence, accident, tampering, or substitution of non-Graco component parts. Nor shall Graco be liable for malfunction, damage or wear caused by the incompatibility of Graco equipment with structures, accessories, equipment or materials not supplied by Graco, or the improper design, manufacture, installation, operation or maintenance of structures, accessories, equipment or materials not supplied by Graco.

This warranty is conditioned upon the prepaid return of the equipment claimed to be defective to an authorized Graco distributor for verification of the claimed defect. If the claimed defect is verified, Graco will repair or replace free of charge any defective parts. The equipment will be returned to the original purchaser transportation prepaid. If inspection of the equipment does not disclose any defect in material or workmanship, repairs will be made at a reasonable charge, which charges may include the costs of parts, labor, and transportation.

**THIS WARRANTY IS EXCLUSIVE, AND IS IN LIEU OF ANY OTHER WARRANTIES, EXPRESS OR IMPLIED, INCLUDING BUT NOT LIMITED TO WARRANTY OF MERCHANTABILITY OR WARRANTY OF FITNESS FOR A PARTICULAR PURPOSE.**

Graco's sole obligation and buyer's sole remedy for any breach of warranty shall be as set forth above. The buyer agrees that no other remedy (including, but not limited to, incidental or consequential damages for lost profits, lost sales, injury to person or property, or any other incidental or consequential loss) shall be available. Any action for breach of warranty must be brought within two (2) years of the date of sale.

**GRACO MAKES NO WARRANTY, AND DISCLAIMS ALL IMPLIED WARRANTIES OF MERCHANTABILITY AND FITNESS FOR A PARTICULAR PURPOSE, IN CONNECTION WITH ACCESSORIES, EQUIPMENT, MATERIALS OR COMPONENTS SOLD BUT NOT MANUFACTURED BY GRACO.** These items sold, but not manufactured by Graco (such as electric motors, switches, hose, etc.), are subject to the warranty, if any, of their manufacturer. Graco will provide purchaser with reasonable assistance in making any claim for breach of these warranties.

In no event will Graco be liable for indirect, incidental, special or consequential damages resulting from Graco supplying equipment hereunder, or the furnishing, performance, or use of any products or other goods sold hereto, whether due to a breach of contract, breach of warranty, the negligence of Graco, or otherwise.

## **FOR GRACO CANADA CUSTOMERS**

The Parties acknowledge that they have required that the present document, as well as all documents, notices and legal proceedings entered into, given or instituted pursuant hereto or relating directly or indirectly hereto, be drawn up in English. Les parties reconnaissent avoir convenu que la rédaction du présente document sera en Anglais, ainsi que tous documents, avis et procédures judiciaires exécutés, donnés ou intentés, à la suite de ou en rapport, directement ou indirectement, avec les procédures concernées.

## Graco Information

For the latest information about Graco products, visit [www.graco.com](http://www.graco.com).

**TO PLACE AN ORDER**, contact your Graco distributor or call to identify the nearest distributor.

**Phone:** 612-623-6921 **or Toll Free:** 1-800-746-1334 **Fax:** 330-966-3006

*All written and visual data contained in this document reflects the latest product information available at the time of publication.*

*Graco reserves the right to make changes at any time without notice.*

*For patent information, see [www.graco.com/patents](http://www.graco.com/patents).*

Original Instructions. This manual contains English. MM 332096

**Graco Headquarters:** Minneapolis

**International Offices:** Belgium, China, Japan, Korea

**GRACO INC. AND SUBSIDIARIES • P.O. BOX 1441 • MINNEAPOLIS MN 55440-1441 • USA**

**Copyright 2010, Graco Inc. All Graco manufacturing locations are registered to ISO 9001.**

[www.graco.com](http://www.graco.com)